



PARTS BOOK

SD22
SD22E
SD22S
SD22D

推土机
BULLDOZER

零件目录

中华人民共和国
山推工程机械股份有限公司

SHANTUI CONSTRUCTION MACHINERY CO.,LTD
THE PEOPLE'S REPUBLIC OF CHINA

前 言

本零件目录对 SD22、SD22E、SD22S、SD22D 四种型号推土机的零件进行了综合编制。

零件号栏内标有 () 的部件，为销售总成号。

发动机所属零件，详见发动机零件目录。

因产品改进所增减的零件，恕不另行通知，以后再版时修订，请用户谅解。

FOREWORD

In this Parts Book are listed parts of bulldozers in 4 models SD22, SD22E, SD22S, SD22D as common part and special.

When a part with () is an assembly part, it is only supplied as part of an assembly.

With regard to parts of engine see "Parts Book of Engine."

Due to continuous research and improvement. Some parts may be changed without notice. Please consult your SHANTUI distributor for items you may require.

目 录

CONTENTS

图 号 页 数
Fig No. Page

1. 发动机关联部件

ENGINE RELATED PARTS

发动机安装	101	3~4
ENGINE MOUNT		
分动箱	102	5~7
TRANSFER CASE		
油门操纵杆	103	8~9
FUEL CONTROL LEVER		
减速踏板	104	10~11
DECELERATOR PEDAL		
油门操纵联动装置	105	12~13
FUEL CONTROL LINKAGE		
散热器	106	14~18
RADIATOR		
散热器管路及护风罩	107	19~21
RADIATOR PIPING AND WIND BREAK		
燃油箱	108	22~23
FUEL TANK		
燃油管路	109	24~25
FUEL PIPING		
排气管及消音器	110	26~27
EXHAUST MANIFOLD AND MUFFLER		
飞轮壳总成	111	28~29
FLYWHEEL HOUSING ASS'Y		
出力装置	112	30~32
POWER TAKE OFF		
出力装置润滑油管	113	33~34
P. T. O LUBRICATING OIL PIPING		
前支架	114	35
FRONT SUPPORT		
空气滤清器及罩	115	36~37
AIR CLEANER AND CAP		
风扇	116	38
FAN		
2. 液力变矩器、变速箱及管路		
TORQUE CONVERTOR, TRANSMISSIN AND PIPING		
万向节	201	41~42
UNIVERSAL JOINT		

液力变矩器壳	202	43~45
TORQUE CONVERTER HOUSING		
涡轮轴和导轮	203	46~48
TURBINE SHAFT AND STATOR		
变速箱壳	204	49~50
TRANSMISSION CASE		
变速箱齿轮和轴 (1/3)	205	51~53
TRANSMISSION GEAR AND SHAFT		
变速箱齿轮和轴 (2/3)	206	54~56
TRANSMISSION GEAR AND SHAFT		
变速箱齿轮和轴 (3/3)	207	57~59
TRANSMISSION GEAR AND SHAFT		
分动箱及齿轮	208	60~61
TRANSFER CASE AND GEAR		
变速控制阀 (1/3)	209	62~63
TRANSMISSION CONTROL VALVE		
变速控制阀 (2/3)	210	64~66
TRANSMISSION CONTROL VALVE		
变速控制阀 (3/3)	211	67~69
TRANSMISSION CONTROL VALVE		
变速控制杆	212	70~72
TRANSMISSION CONTROL LEVER		
变速控制连杆 (1/3)	213	73~74
TRANSMISSION CONTROL LINKAGE		
变速控制连杆 (2/3)	214	75~76
TRANSMISSION CONTROL LINKAGE		
变速控制连杆 (3/3)	215	77~78
TRANSMISSION CONTROL LINKAGE		
变速泵	216	79~80
TRANSMISSION PUMP		
液力变矩器管路 (1/2)	217	81~83
TORQUE CONVERTER PIPING		
液力变矩器管路 (2/2)	218	84~85
TORQUE CONVERTER PIPING		
变速管路	219	86~88
TORQFLOW TRANSMISSION PIPING		
3. 转向箱及终传动		
STEERING CASE AND FINAL DRIVE		
转向箱及主机架	301	91~92
STEERING CASE AND MAIN FRAME		
伞齿轮及轴	302	93~94
BEVEL GEAR AND SHAFT		

转向离合器	303	95~96
STEERING CLUTCH		
制动带及联动装置	304	97~98
BRAKE BAND AND LINKAGE		
制动盖	305	99~100
BRAKE CASE COVER		
制动助力器	306	101~102
BRAKE BOOSTER		
终传动箱及齿轮 (1/2)	307	103~104
FINAL DRIVE CASE AND GEAR		
终传动箱及齿轮 (2/2)	308	105~106
FINAL DRIVE CASE AND GEAR		
链轮及轴	309	107~108
SPROCKET AND SHAFT		
转向控制杆	310	109~110
STEERING CONTROL LEVER		
转向制动连杆 (1/2)	311	111~112
STEERING AND BRAKE LINKAGE		
转向制动连杆 (2/2)	312	113~114
STEERING AND BRAKE LINKAGE		
制动踏板	313	115~116
BRAKE PEDAL		
制动闭锁杆	314	117~118
BRAKE PARKING LEVER		
转向泵	315	119~120
STEERING PUMP		
转向阀	316	121~123
STEERING CONTROL VALVE		
主调压阀	317	124~125
MAIN RELIEF VALVE		
精滤油器	318	126~127
TRANSMISSION OIL FILTER		
粗滤油器	319	128~129
OIL STRAINER		
转向管路 (1/3)	320	130~131
STEERING PIPING		
转向管路 (2/3)	321	132~133
STEERING PIPING		
转向管路 (3/3)	322	134~135
STEERING PIPING		
制动管路	323	136~137
BRAKE PIPING		
集中润滑管路	324	138~139
CONCENTRATED PIPING		
集中测压管路	325	140~141
TEST PRESSURE PIPING		

4. 行走装置

TRACK MECHANISM

台车架·····	401···145~146
TRACK FRAME	
涨紧装置·····	402···147~149
RECOIL MECHANISM	
台车架盖·····	403···150~151
TRACK FRAME COVER	
履带滚轮护轨 ·····	404···152~153
TRACK ROLLER GUARD	
引导轮 ·····	405···154~155
IDLER	
支重轮 ·····	406···156~157
TRACK ROLLER	
托轮 ·····	407···158~159
CARRIER ROLLER	
履带（标准型）·····	408···160~161
TRACK SHOE（STD）	
履带（润滑型）·····	409···162~163
TRACK SHOE(LUBRICATE TYPE)	

5. 护罩

GUARD

散热器护架·····	501···167~168
RADIATOR GUARD	
发动机罩·····	502···169~171
ENGINE HOOD	
翼板 ·····	503···172~174
FENDER	
支撑 ·····	504···175~177
SUPPORT	
地板架 ·····	505···178~180
FLOOR FRAME	
蓄电池罩 ·····	506···181~182
BATTERY COVER	
底护板 ·····	507···183~184
BOTTOM GUARD	
油缸支架 ·····	508···185~186
CYLINDER SUPPORT	
防翻滚架 ·····	509···187~188
ROLLOVER PROTECTIVE STRUCTURE	
防翻滚架安装 ·····	510···189~190
ROLLOVER PROTECTIVE STRUCTURE MOUNT	
平衡梁 ·····	511···191~192
EQUALIZER BAR	

牵引架	512	193~194
DRAWBAR		
牵引架(湿地型)	513	195~196
DRAWBAR(FOR TSY220B)		
驾驶室	514	197~198
CAB		
司机座	515	199~200
OPERATOR SEAT		
6. 附属装置控制系统		
ATTACHMENT CONTROL SYSTEM		
液压泵	601	203~204
HYDRAULIC PUMP		
液压油箱(1/2)	602	205~206
HYDRAULIC TANK		
液压油箱(2/2)	603	207~208
HYDRAULIC TANK		
液压滤油器	604	209~210
HYDRAULIC FILTER		
铲刀提升和倾斜操纵阀(1/2)	605	211~213
BLADE LIFT AND TILT CONTROL VALVE		
铲刀提升和倾斜操纵阀(2/2)	606	214~215
BLADE LIFT AND TILT CONTROL VALVE		
松土器控制阀(1/2)	607	216~217
RIPPER CONTROL VALVE		
松土器控制阀(2/2)	608	218~219
RIPPER CONTROL VALVE		
铲刀提升油缸(1/2)	609	220~222
BLADE LIFT CYLINDER		
铲刀提升油缸(2/2)	610	223~224
BLADE LIFT CYLINDER		
倾斜油缸	611	225~226
BLADE TILT CYLINDER		
液压管路(自箱至泵)	612	227~228
HYDRAULIC PIPING(from tank to pump)		
液压管路(自箱至升降缸)(1/2)	613	229~230
HYDRAULIC PIPING(from tank to lift cylinder)		
液压管路(自箱至升降缸)(2/2)	614	231~232
HYDRAULIC PIPING(from tank to lift cylinder)		
液压管路(SD22S用)(1/2)	615	233~234
HYDRAULIC PIPING(For SD22S)		
液压管路(SD22S用)(2/2)	616	235~236
HYDRAULIC PIPING(For SD22S)		
液压管路(自箱至倾斜缸)(1/2)	617	237~238
HYDRAULIC PIPING(from tank to tilt cylinder)		
液压管路(自箱至倾斜缸)(2/2)	618	239~240
HYDRAULIC PIPING(from tank to tilt cylinder)		

液压管路(SD22S 用) (1/2)	619	241~243
HYDRAULIC PIPING(For SD22S)		
液压管路(SD22S 用) (2/2)	620	244~245
HYDRAULIC PIPING(For SD22S)		
倾斜及松土器操纵随动阀	621	246~248
TILT AND RIPPER CONTROL SERVO VALVE		
随动阀管路	622	249~250
SERVO VALVE PIPING		
操纵杆托架及阀座	623	251~252
CONTROL LEVER BRACKET AND VALVE SEAT		
铲刀操纵杆	624	253~255
BLADE CONTROL LEVER		
松土器操纵杆	625	256~257
RIPPER CONTROL LEVER		
升降及松土器操纵联动装置	626	258~259
LIFT AND RIPPER CONTROL LINKAGE		
倾斜操纵联动装置	627	260~261
TILT CONTROL LINKAGE		
铲刀操纵联动装置	628	262~263
BLADE CONTROL LINKAGE		
升降操纵随动阀	629	264~266
LIFT CONTROL SERVO VALVE		
7. 工作装置		
WORK EQUIPMENT		
半 U 型铲	701	269~270
BLADE SEMI-U DOZER		
直倾铲	702	271~272
STRAVGH TILT BLADE		
推杆	703	273~275
STRAIGHT TILT FRAME		
直倾铲 (SD22S 用)	704	276~277
STRAVGH TILT BLADE(For SD22S)		
推杆 (SD22S 用)	705	278~279
STRAIGHT TILT FRAME(For SD22S)		
松土器	706	280~282
RIPPER		
松土器管路	707	283~284
RIPPER PIPING		
松土器油缸	708	285~287
RIPPER CYLINDER		
角铲	709	288~289
ANGLE BLADE		
弓形架	710	290~291
U-FRAME		
U 型铲	711	292~293
U-BLADE		

8. 电气系统

ELECTRICAL SYSTEM

电气系统(1/2)801...297~298

ELECTRICAL SYSTEM

电气系统(2/2)802...299~300

ELECTRICAL SYSTEM

仪表箱803...301~302

INSTRUMENT BOX

继电器和保险丝盒804...303~304

RELAY AND FUSE BOX

蓄电池和电池继电器805...305~306

BATTERY AND RELAY SWITCH

9. 标牌布置图

MARK AND PLATE

标牌布置图901...309~310

MARK AND PLATE

发动机关联部件
ENGIEN RELATED PARTS

第 101 图 发动机悬挂
FIG.101 ENGINE MOUNT

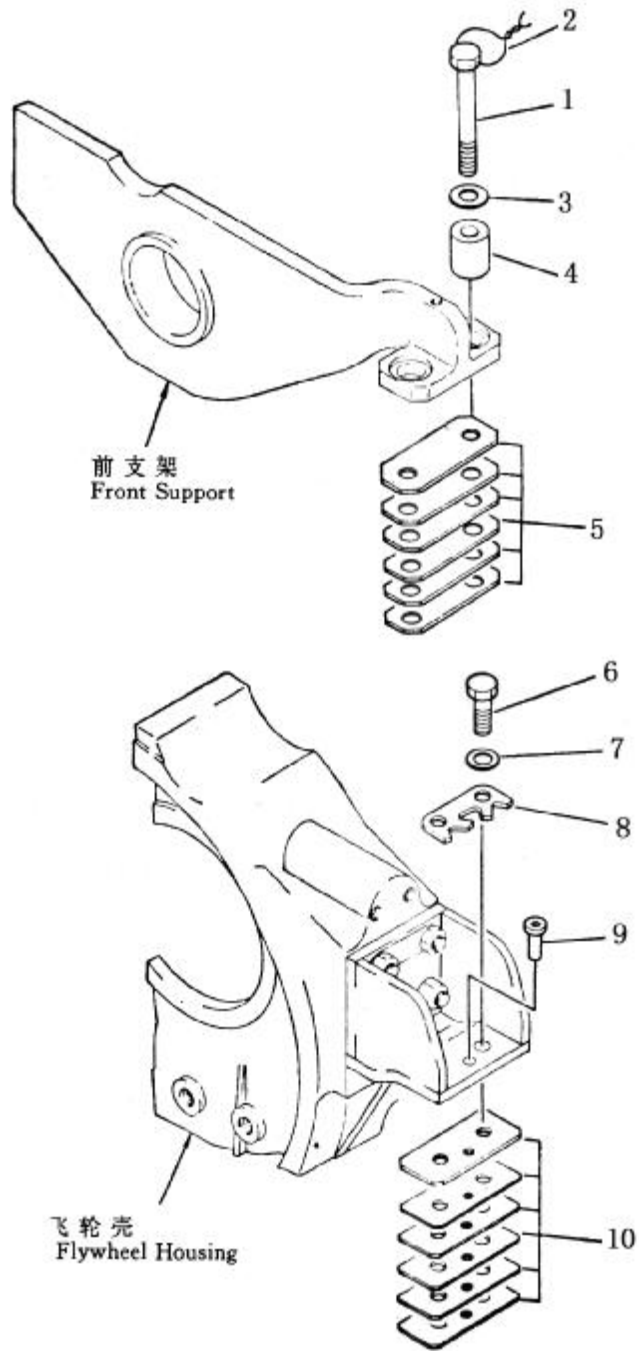

发动机悬挂
ENGINE MOUNT

序 号 INDEX NO.	图 号 PART NO.	名 称 DESCRIPTION	数量 Q`TY
101-1	01015-52200	前螺栓 bolt, front	4
2	04059-01680	锁紧用钢丝 wire, lock	2
3	01643-32260	垫圈 washer	4
4	195-01-11190	衬垫 spacer	4
5	154-01-11570	前垫板总成 shim ass' y, front	2
	154-01-11580	前垫板总成 shim ass' y, front	10
6	01010-52255	后螺栓 bolt, rear	4
7	154-01-11550	垫圈 washer	4
8	154-01-11560	锁垫板 plate, lock	2
9	6681-21-4750	定位销 pin, dowel	2
10	154-01-11590	后垫板总成 shim ass' y, back	2
	154-01-11610	后垫板总成 shim ass' y, back	10

第 102 图 分 动 箱
 FIG.102 TRANSFER CASE

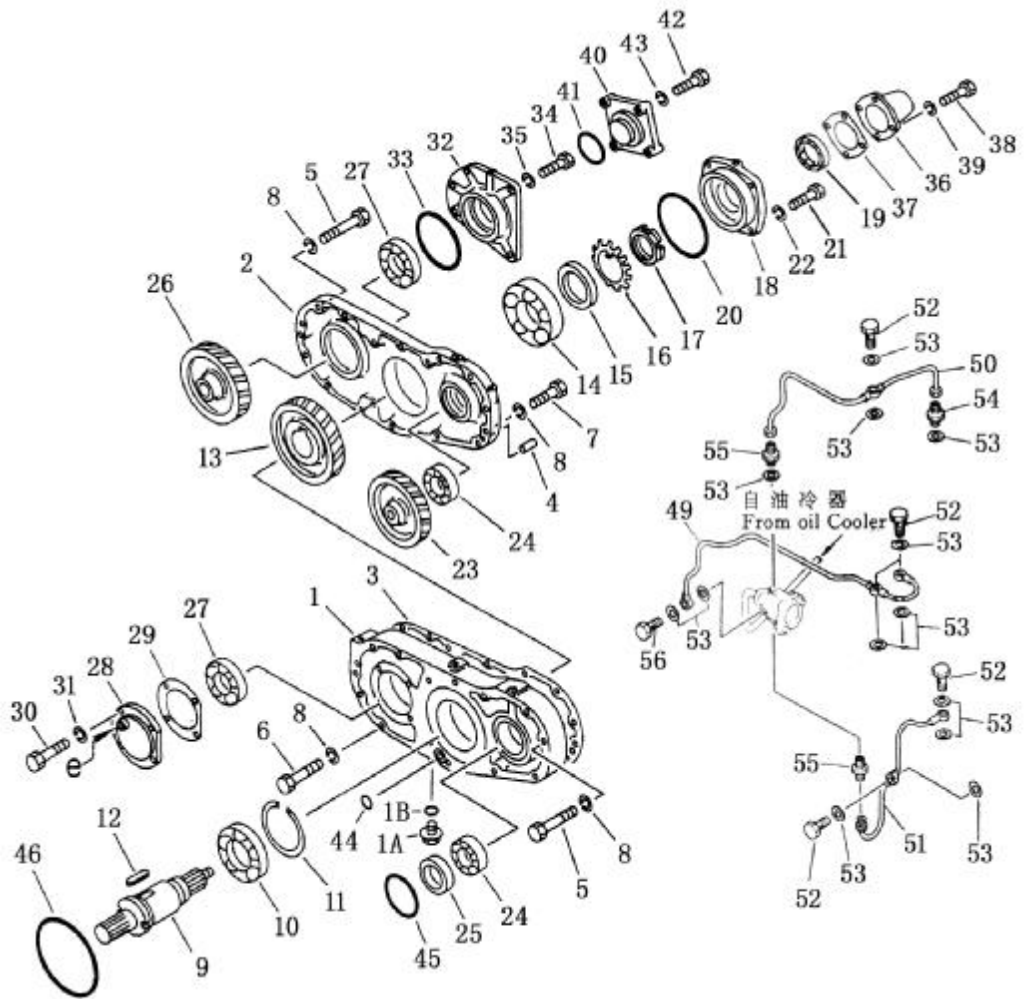

分动箱 TRANSFER CASE

图及索引号码 Fig & Index No.	件 号 Part No.	名 称 Description	数量 Q'ty
	23Y-02B-00000	分动箱总成 power take off ass'y	1
102-1	154-38-25110	齿轮箱 case	1
1A	07044-12412	堵 play	1
1B	07002-02434	O形圈 O-ring	1
2	154-01-12121	分动箱 case power take off	1
3	154-01-12131	(箱) 填密垫 gasket , case	1
4	04020-01024	定位销 pin , dowel	2
5	01011-51205	螺栓 bolt	13
6	01010-51275	螺栓 bolt	2
7	01010-51250	螺栓 bolt	2
8	01602-21236	弹簧垫圈 washer spring	17
9	154-01-12220	轴 shaft	1
10	154-01-12280	滚柱轴承 bearing roller	1
11	150-21-22180	卡环 ring snap	1
12	04000-02050	键 key	2
13	154-01-12230	齿轮 gear	1
14	06040-06314	滚珠轴承 bearing ball	1
15	154-01-12240	套环 collar	1
16	01658-16823	锁紧垫圈 washer lock	1
17	01530-06814	螺母 nut	1
18	154-01-12250	盖 cover	1
19	07012-00060	油封 seal oil	1
20	07000-05150	O形圈 O-ring	1
21	01010-51230	螺栓 bolt	4
22	01602-21236	弹簧垫圈 washer , spring	4
23	154-38-25150	齿轮 gear	1
24	06040-06209	滚珠轴承 bearing ball	2
25	154-01-12320	环 ring	1
26	154-01-12410	齿轮 gear	1
27	06040-06212	滚柱轴承 bearing roller	2
28	154-01-12420	盖 cover	1
29	154-01-12431	填密垫 gasket	1
30	01010-51025	螺栓 bolt	4
31	01602-21030	弹簧垫圈 washer spring	4
32	154-01-12440	轴承盖 case , bearing	1
33	07000-05130	O形圈 O-ring	1
34	01010-51250	螺栓 bolt	2
35	01602-21236	弹簧垫圈 washer spring	2
36	154-01-12260	盖 cover	1

分动箱
TRANSFER CASE

图及索引号码 Fig & Index No.	件 号 Part No.	名 称 Description	数量 Q'ty
102-37	154-01-12271	填密垫 gasket	1
38	01010-51025	螺栓 bolt	4
39	01602-21030	弹簧垫圈 washer spring	4
40	154-01-12450	盖 cover	1
41	07000-03078	O形圈 o-ring	1
42	01010-51245	螺栓 bolt	4
43	01602-21236	弹簧垫圈 washer spring	4
44	07000-03030	O形圈 o-ring	1
45	07000-02105	O形圈 o-ring	1
46	07000-05195	O形圈 o-ring	1
49	154-01-12530	管 tube	1
50	154-01-12541	管 tube	1
51	154-01-12552	管 tube	1
52	6600-01-3860	螺栓管接头 bolt, joint	5
53	07005-01012	填密垫 gasket	15
54	154-01-12520	管接头 nipple	1
55	07211-50610	管接头 nipple	2
56	07206-10610	连接螺栓 bolt, link	1

第103图 油门操纵杆
FIG.103 FUEL CONTROL LEVER

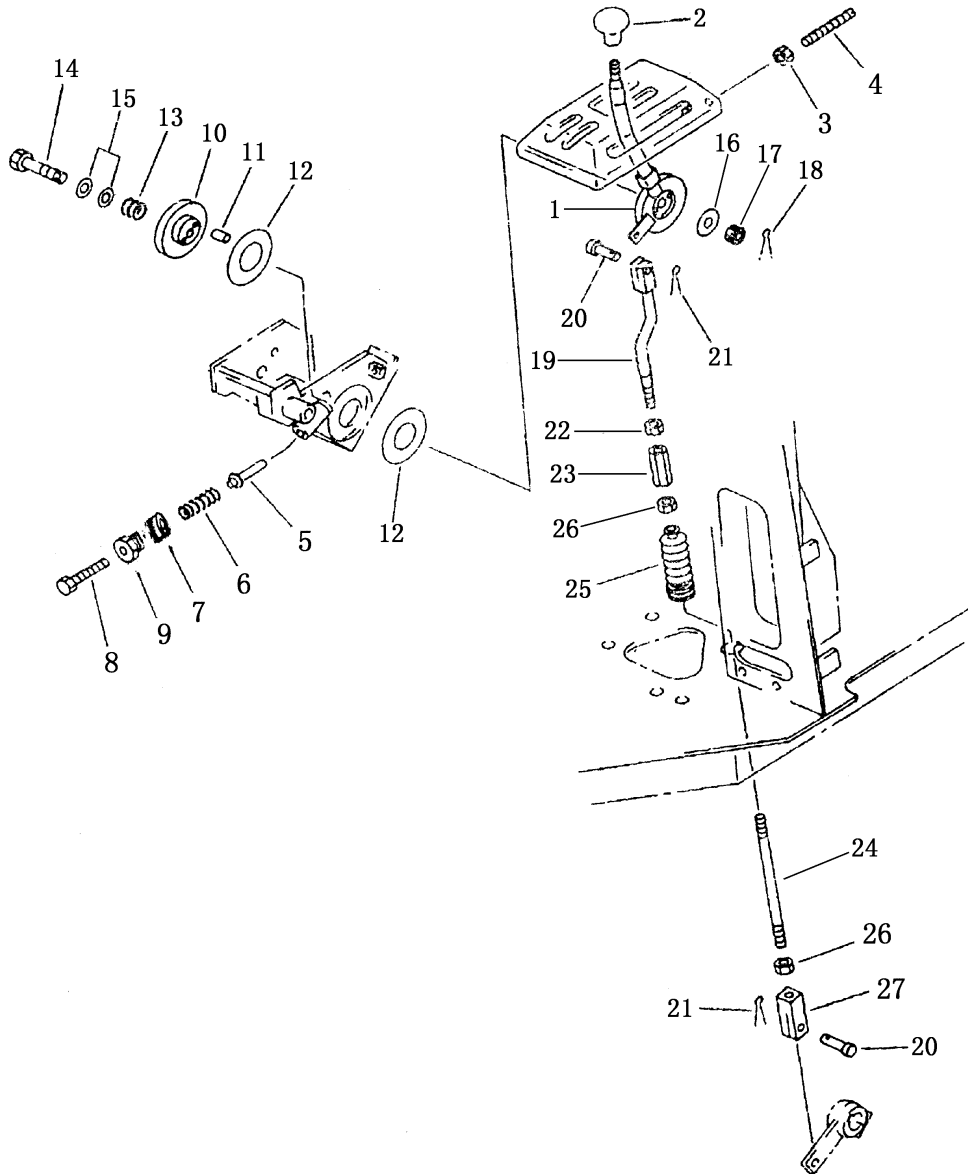

油门操纵杆 FUEL CONTROL LEVER

图及索引号码 Fig & Index No.	件 号 Part No.	名 称 Description	数量 Q'ty
103-1	154-43-44110	油门操纵杆 lever	1
2	09304-01250	手柄 knob	1
3	GB6172-86	六角薄螺母 M10 nut	1
4	154-43-44270	螺钉 screw	1
5	17Y-05-00008	销 pin	1
6	170-54-11230	弹簧 spring	1
7	17Y-05-00006	垫 washer	1
8	01016-50860	螺栓 M8×60 bolt	1
9	154-43-44250	螺帽 cap	1
10	154-43-14710	园盘 disc	1
11	04020-00616	销 6×16 pin	1
12	101-43-11281	磨擦衬片 facing	2
13	154-43-14710	弹簧 spring	1
14	01052-51265	螺栓 M12×1.5×65 bolt	1
15	01640-21223	垫圈 12 washer	2
16	101-43-11380	垫 cover	1
17	01593-11210	螺母 M12×1.5 nut	1
18	04050-13030	开口销 3×30 pin	1
19	154-43-44120	杆 rod	1
20	04205-10822	销轴 8×22 pin	2
21	04050-12016	开口销 2×16 pin cotter	2
22	01508-21006	螺母 M10×1.25 左 nut	1
23	178-43-12180	调整螺母 adjusting nut	1
24	04245-41025	杆 rod	1
25	195-43-42280	橡胶套 bellows	1
26	01582-11008	螺母 M10×1.25 nut	2
27	198-43-18170	叉口板 yoke	1

第 104 图 减速踏板
 FIG.104 DECELERATOR PEDAL

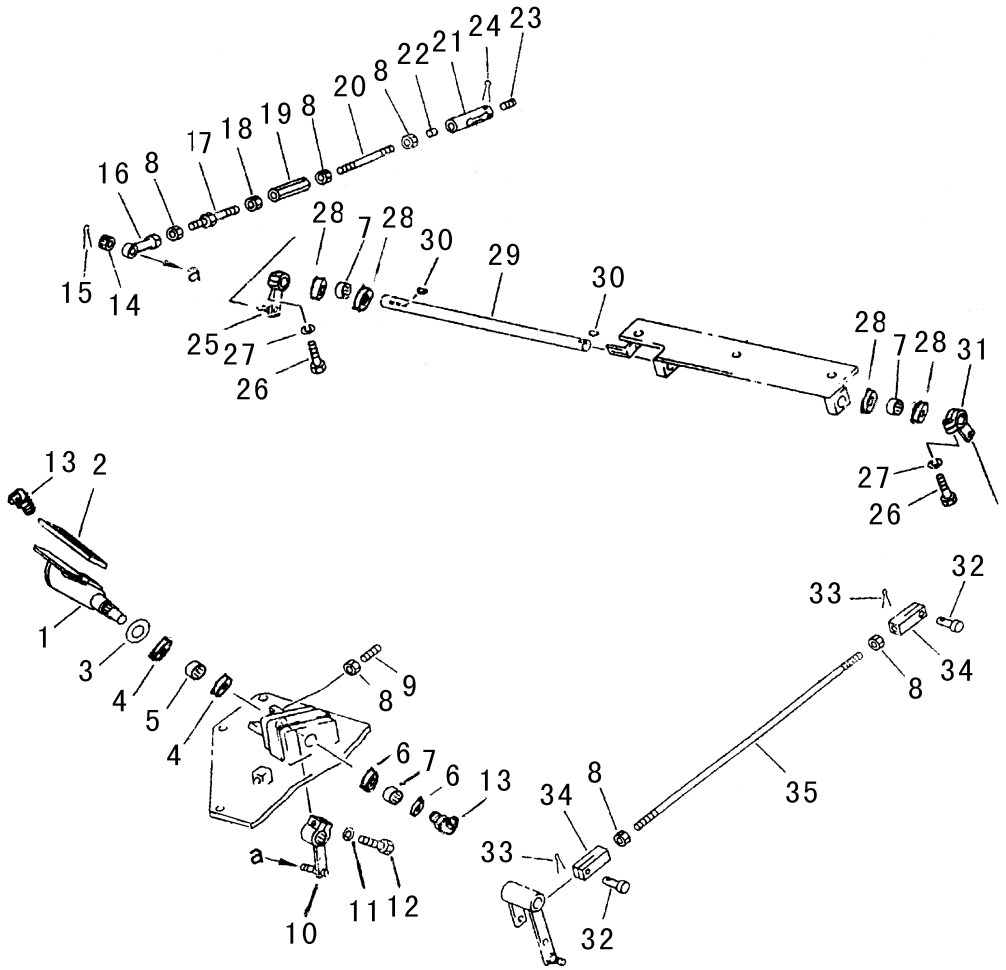

减 速 踏 板

DECCELERATOR PEDAL

图及索引号码 Fig & Index No.	件 号 Part No.	名 称 Description	数量 Q'ty
104-1	195-43-42350	脚踏板 pedal	1
2	17Y-05-00016	橡胶板 plate rubber	1
3	01643-32460	垫圈 washer	1
4	06122-02504	防尘密封圈 seal ring	2
5	GB290-82	只有冲压外圈的滚针 轴承 20941/25 bearing, roller needle	1
6	06122-02004	防尘密封圈 seal ring	2
7	GB290-82	只有冲压外圈的滚针 轴承 37941/20 bearing, roller needle	3
8	01582-11008	螺母 M10×1.25 nut	6
9	175-43-35210	螺钉 screw	1
10	17Y-05-08000	杠杆 lever	1
11	01643-31032	垫圈 10 washer	1
12	01010-51040	螺栓 M10×40 bolt	1
13	07021-01090	接头式压注油杯 fitting grease	2
14	01593-11008	螺母 M10×1.25 bolt	1
15	04050-12018	开口销 2×18 pin cotter	1
16	04250-81056	关节轴承 end rod	1
17	04248-31016	杆 rod	1
18	01508-21006	螺母 M10×1.25 左 nut	1
19	176-43-43190	调整螺母 adjusting nut	1
20	04245-41016	杆 rod	1
21	195-43-42410	调整螺母 adjusting nut	1
22	17Y-05-00019	挡销 pin, stopper	1
23	154-44-14570	挡销 pin, stopper	1
24	04050-12022	开口销 2×22 pin cotter	1
25	154-43-44231	杠杆 lever	1
26	01010-50830	螺栓 M8×30 bolt	2
27	01602-20825	垫圈 8 washer spring	2
28	06122-02004	防尘密封圈 seal ring	4
29	154-43-44240	轴 shaft	1
30	04010-00519	半园键 half-round key	2
31	17Y-05-10000	杠杆 lever	1
32	04205-10822	销轴 8×22 pin	2
33	04050-12016	开口销 2×16 pin cotter	2
34	198-43-18170	叉口板 yoke	2
35	04245-41062	杆 rod	1

第 105 图 油门操纵联动装置
 FIG.105 FUEL CONTROL LINKAGE

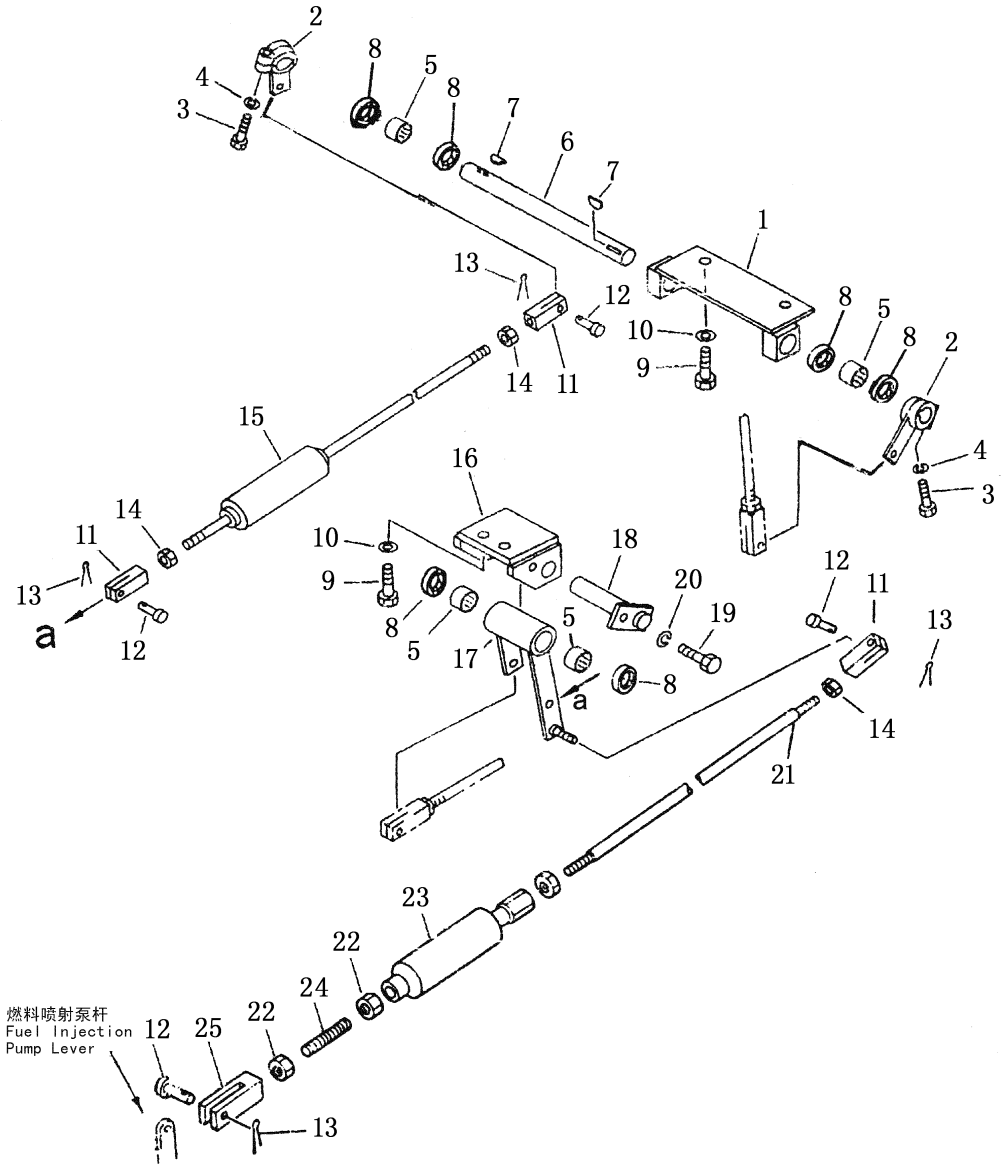

油门操纵联动装置
FUEL CONTROL LINKAGE

图及索引号码 Fig & Index No.	件 号 Part No.	名 称 Description	数量 Q' ty
105-1	17Y-05-11000	支架 bracket	1
2	17Y-05-10000	杠杆 lever	2
3	01010-50830	螺栓 M8×30 bolt	2
4	01602-20825	垫圈 8 washer spring	2
5	GB290-82	只有冲压外圈的滚针 bearing 轴承 37941/20	4
6	154-43-44140	轴 shaft	1
7	04010-00519	半园键 key wood ruff	2
8	06122-02004	防尘密封圈 seal ring	6
9	01010-51230	螺栓 M12×30 blot	4
10	01643-31232	垫圈 12 washer	4
11	198-43-18170	叉口板 yoke	3
12	04205-10822	销轴 8×22 pin	4
13	04050-12016	开口销 2×16 pin cotter	4
14	01582-11008	螺母 M10×1.25 nut	3
15	154-43-44162	杆组件 rod ass'y	1
16	17Y-05-05000	支架 bracket	1
17	17Y-05-06000	杠杆 lever	1
18	17Y-05-04000	轴 shaft	1
19	01010-51016	螺栓 M10×16 bolt	1
20	01602-21030	垫圈 10 washer	1
21	23Y-05B-00001	杆 rod	1
22	01580-10806	螺母 M8×1 nut	3
23	09290-10000	缓冲器 absorber	1
24	04245-40806	拉杆 rod	1
25	04211-20844	叉口板 yoke	1

第 106 图 散热器
FIG.106 RADIATOR

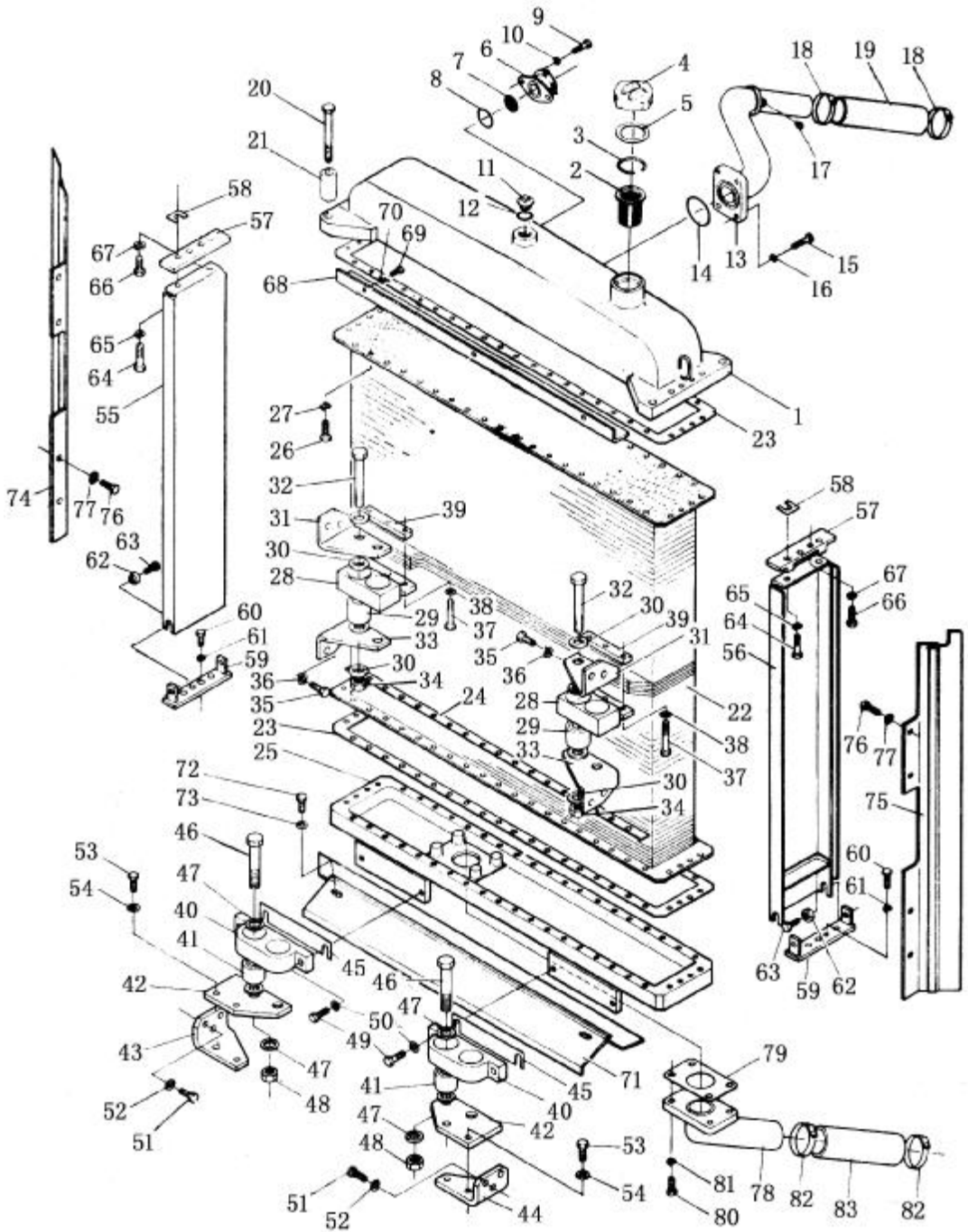

散热器 RADIATOR

序号 No.	图 号 PART NO.	名 称 DESCRIPTION	数量 Q' ty		
			SD22 SD22E	SD22D	SD22S
	154-03-C1001	散热器总成	radiator ass' y	1	
	22M-03-00000	散热器总成	radiator ass' y		1
106-1	(TS220、03)	散热器总成	radiator ass' y		1
	154-03-11117	上箱	tank, upper	1	1
	22M-03-80700	上箱	tank, upper		1
2	07056-00048	过滤器	strainer	1	1
3	07057-03271	卡环	ring	1	1
4	07053-10000	箱帽	cap	1	1
5	07053-00002	填密垫	gasket	1	1
6	154-03-11682	压力阀	valve, pressure	1	1
	22M-03-81000	压力阀	valve, pressure		1
7	175-03-32570	滤网	screen	1	1
	22M-03-80800	滤网	screen		1
8	07000-43045	O型圈	o-ring	1	1
9	01010-51025	螺栓	bolt	2	2
10	01602-21030	垫圈	washer	2	2
11	07040-13618	螺塞	plug	1	1
12	07002-43634	O型圈	o-ring	1	1
13	154-03-11565	管总成	tube ass' y	1	1
14	07000-42070.	O型圈	o-ring	1	1
15	01010-51240	螺栓	bolt	4	4
16	01602-21236	垫圈	washer	4	4
17	07042-30108	螺塞	plug	1	1
18	07281-00809	喉箍	clamp	2	2
19	154-03-11574	软管	hose	1	1
20	01011-51640	螺栓	bolt	4	4
21	154-03-13240	轴套	spacer	4	4
22	154-03-21132	型心	core	1	1
	22M-03-80500	型心	core		1
23	154-03-11143	填密垫	gasket	2	2
	22M-03-80004	填密垫	gasket		2
24	154-03-11151	垫板	plate	4	4
	22M-03-80005	垫板	plate		4

散热器 RADIATOR

序号 No.	图号 PART NO.	名称 DESCRIPTION	数量 Q' ty		
			SD22 SD22E	SD22D	SD22S
106-25	154-03-21123	下箱 tank, lower	1		1
	22M-03-80200	下箱 tank, lower		1	
26	01010-51030	螺栓 bolt	80	80	80
27	01602-21030	垫圈 washer	80	80	80
	195-03-22400	减振器总成 isolator ass' y	2		2
	22M-03-80400	减振器总成 isolator ass' y		2	
28	195-03-22530	托架 bracket	2		2
	22M-03-80410	托架 bracket		2	
29	195-03-22520	减振器 isolator	4		4
	22M-03-80110	减振器 isolator		4	
30	01643-32260	加厚垫圈 washer	16	16	16
31	154-03-13160	上托架 bracket, upper	2	2	2
32	01091-52220	螺栓 bolt	4	4	4
33	154-03-13170	下托架 bracket, lower	2	2	2
34	01582-12218	螺母 nut	4	4	4
35	01010-51230	螺栓 bolt	8	8	8
36	01643-31232	加厚垫圈 washer	8	8	8
37	01010-51230	螺栓 bolt	6	6	6
38	01643-31032	加厚垫圈 washer	6	6	6
39	198-03-21530	压板 plate	2		2
	22M-03-80003	压板 plate		2	
	195-03-22500	减振器总成 isolator ass' y	2		2
	22M-03-80100	减振器总成 isolator ass' y		2	
40	195-03-22540	托架 bracket	2		2
	22M-03-80101	托架 bracket		2	
41	195-03-22520	减振器 isolator	4		4
	22M-03-80110	减振器 isolator		4	
42	195-03-13250	托架 bracket	2	2	2
43	154-03-11973	托架(右) bracket, R.H	1	1	1
44	154-03-11963	托架(左) bracket, L.H	1	1	1
45	195-03-22270	垫片 shim	12		12
	22M-03-80001	垫片 shim		12	
46	01091-52205	螺栓 bolt	4	4	4
47	01643-32260	加厚垫圈 washer	12	12	12
48	01582-12218	螺母 nut	4	4	4

散热器 RADIATOR

序号 No.	图 号 PART NO.	名 称 DESCRIPTION	数量 Q' ty		
			SD22 SD22E	SD22D	SD22S
106-49	01010-51245	螺栓 bolt	4	4	4
50	01643-31232	加厚垫圈 washer	4	4	4
51	0101051230	螺栓 bolt	6	6	6
52	01643-31232	加厚垫圈 washer	6	6	6
53	01010-51435	螺栓 bolt	4	4	4
54	01643-31445	加厚垫圈 washer	4	4	4
55	154-03-12842	遮护罩 (右) winder-break, R. H	1		1
	22M-03-81100	遮护罩 (右) winder-break, R. H		1	
56	154-03-12823	遮护罩 (左) winder-break, L. H	1		1
	22M-03-80900	遮护罩 (左) winder-break, L. H		1	
57	154-03-13140	垫 gasket	2		2
	22M-03-80600	垫 gasket		2	
58	154-03-11611	填片 shim	20	20	20
59	154-03-13150	板 plate	2		2
	22M-03-80300	板 plate		2	
60	01010-51235	螺栓 bolt	8	10	8
61	01602-21236	垫圈 washer	8	10	8
62	154-03-22160	座 seat	4		4
	22M-03-80002	座 seat		4	
63	01010-51030	螺栓 bolt	4	4	4
64	01010-51250	螺栓 bolt	4	6	4
65	01602-21236	垫圈 washer	4	6	4
66	01010-51235	螺栓 bolt	4	4	4
67	01602-21236	垫圈 washer	4	4	4
68	154-03-12771	护风罩 wind-break	1	1	1
69	01010-51020	螺栓 bolt	3	3	3
70	01643-31032	加厚垫圈 washer	3	3	3
71	23Y-03B-02000	护风罩 wind-break	1	1	
	TS220、03、1	护风罩 wind-break			1
72	01010-51025	螺栓 bolt	2	2	2
73	01643-31032	加厚垫圈 washer	2	2	2

散热器 RADIATOR

序号 No.	图 号 PART NO.	名 称 DESCRIPTION	数量 Q' ty		
			SD22 SD22E	SD22D	SD22S
106-74	154-03-12792	护风罩 (右) winder-break, R. H	1	1	
	TS220、03、2	护风罩 (右) winder-break, R. H			1
75	23Y-03B-01000	护风罩 (左) winder-break, L. H	1	1	
	TS220、03、3	护风罩 (左) winder-break, L. H			1
76	01010-51235	螺栓 bolt	8	8	8
77	01643-31232	加厚垫圈 washer	8	8	8
78	154-03-11587	弯管 tube	1	1	1
79	154-03-11361	填密垫 gasket	1	1	1
80	01010-51235	螺栓 bolt	4	4	4
81	01602-21236	垫圈 washer	4	4	4
82	07281-00909	喉箍 clamp	2	2	2
83	154-03-11594	软管 hose	1	1	1

第 107 图

散热器管路及护风罩

FIG.107 RADIATOR PIPING AND WIND BREAK

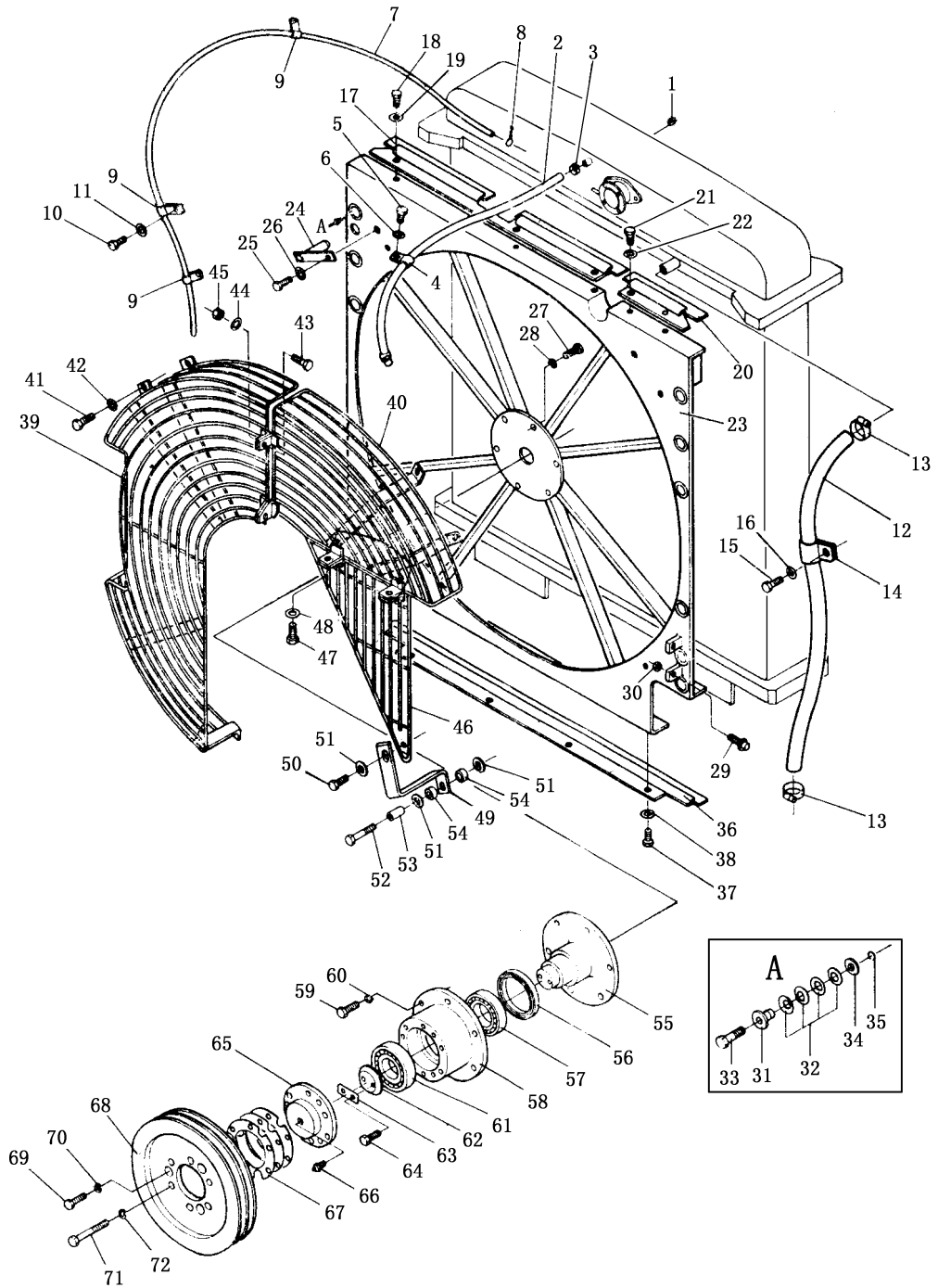

散热器管路及护风罩

RADIATOR PIPING AND WIND BREAK

序号 No.	图 号 PART NO.	名 称 DESCRIPTION	数量 Q' ty				
			SD22 SD22E	SD22D	SD22S		
107-1	154-03-C1001	散热器总成	radiator ass' y	1			
	22M-03-00000	散热器总成	radiator ass' y		1		
	TS220、03	散热器总成	radiator ass' y			1	
	01049-01012	堵 10	plug	1		1	
	2	154-03-11522	软管	hose	1		1
	3	07281-00197	喉箍	clamp	2		2
	4	08036-01814	管夹	clip	1		1
	5	01010-51220	螺栓	bolt	1		1
	6	01643-31232	加厚垫圈	washer	1		1
	7	195-03-13131	管	tube	1		1
	8	04059-01010	铁丝 19#	wire	1		1
	9	195-03-11690	夹子	clip	3		3
	10	01010-51220	螺栓	bolt	2		2
	11	01043-31232	加厚垫圈	washer	2		2
	12	154-03-11535	软管	hose	1		1
	13	07281-00419	喉箍	clamp	2		2
	14	195-03-11511	夹子	clip	1		1
	15	01010-51225	螺栓	bolt	1		1
	16	01643-31232	加厚垫圈	washer	1		1
	17	154-03-13231	护风罩 (左上)	wind-break, L. H	1		1
	18	01010-51225	螺栓	bolt	3		3
	19	01643-31232	加厚垫圈	washer	3		3
	20	154-03-13270	护风罩 (右上)	wind-break, R. H	1		1
	21	01010-51225	螺栓	bolt	2		2
	22	01643-31232	加厚垫圈	washer	2		2
	23	154-03-12626	保护架	guard	1		1
	24	175-03-32710	销	pin	1		1
	25	01010-51230	螺栓	bolt	1		1
	26	01643-31232	加厚垫圈	washer	1		1
	27	01010-51235	螺栓	bolt	6		6
	28	01602-21236	垫圈	washer	6		6
	29	09311-31237	缓冲螺栓	bolt	4		4
	30	01580-11210	螺母	nut	4		4
	31	154-03-13180	衬套	spacer	12		12
	32	175-54-27350	弹簧	spring	48		48
	33	01010-51255	螺栓	bolt	12		12
34	01643-32060	加厚垫圈	washer	12		12	
35	175-04-28770	卡环	ring	12		12	
36	154-03-12833	护风罩	wing-break	1		1	

散热器管路及护风罩
RADIATOR PIPING AND WIND BREAK

序号 No.	图 号 PART NO.	名 称 DESCRIPTION		数量 Q' ty		
				SD22 SD22E	SD22D	SD22S
107-37	01010-51020	螺栓	bolt	4	4	4
38	01643-31032	加厚垫圈	washer	4	4	4
39	154-03-12644	网 (左)	net, L. H.	1	1	1
40	154-03-12634	网 (右上)	net, R. H.	1	1	1
41	01010-51230	螺栓	bolt	6	6	6
42	01643-31232	加厚垫圈	washer	6	6	6
43	01010-51230	螺栓	bolt	2	2	2
44	01643-31232	加厚垫圈	washer	2	2	2
45	01580-11210	螺母	nut	2	2	2
46	154-03-12653	网 (右下)	net, R. H. lower	1	1	1
47	01010-51230	螺栓	bolt	2	2	2
48	01643-31232	加厚垫圈	washer	2	2	2
49	154-03-12871	撑条	support	1	1	
	TS220、03-3	撑条	support			1
50	01010-51230	螺栓	bolt	1	1	1
51	124-54-26540	垫圈	washer	3	3	3
52	01010-51265	螺栓	bolt	1	1	1
53	170-03-13130	衬垫	spacer	1	1	1
54	154-03-12880	座垫	seat	2	2	2
55	154-03-C1110	轴	shaft	1	1	1
56	07011-10090	骨架油封	seal	1	1	1
57	06040-06212	单列向心球轴承	bearing	1	1	1
58	154-03-C1120	罩壳	cage	1	1	1
59	01010-51235	螺栓	bolt	6	6	6
60	01602-21236	垫圈	washer	6	6	6
61	06040-06310	单列向心球轴承	bearing	1	1	1
62	195-03-11840	压板	plate	1	1	1
63	195-03-11850	锁垫	lock	1	1	1
64	01010-51030	螺栓	bolt	2	2	2
65	155-03-11850	盖	cover	1	1	1
66	07020-00000	直通式压注油杯	fitting, grease	1	1	1
67	195-03-11880	填片	shim	14	14	14
68	154-03-11981	皮带轮	pulley	1		1
	22M-03-00001	皮带轮	pulley		1	
69	01010-51030	螺栓	bolt	3	3	3
70	01602-21030	垫圈	washer	3	3	3
71	01016-51270	螺栓	bolt	6	6	6
72	01602-21236	垫圈	washer	6	6	6

第 108 图 燃油箱
FIG.108 FUEL TANK

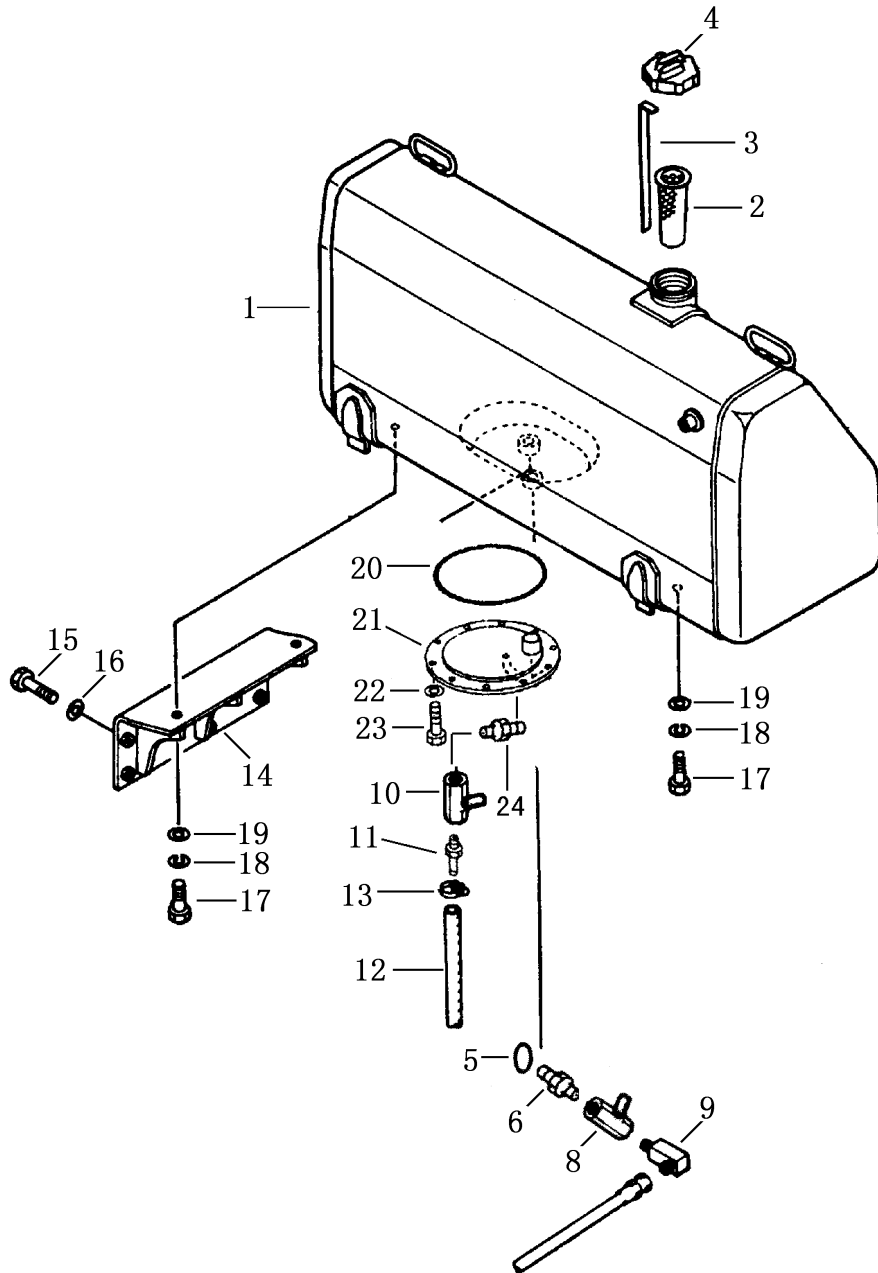

燃 油 箱
FUEL TANK

序号 Index No.	件 号 Part No.	名 称 Description	数量 Q' ty
108-1	23Y-04B-01000	燃油箱 fuel tank	1
2	07056-18416	滤网 strainer	1
3	23Y-04B-00001	油尺 gauge	1
4	23Y-04B-02000	油箱盖 cap	1
5	07002-02434	O 型圈 O-ring	1
6	23Y-04-00006	接头 joint	1
8	07700-40460	阀门 valve	1
9	23Y-04-00004	弯头 elbow	1
	(07042-00108)	螺塞 PT' plug	1
10	07000-40460	放水阀 valve	1
11	23Y-04-00002	放水接头 joint	1
12	07270-01265	软管 tube	1
13	07280-01210	软管夹 clamp	1
14	23Y-04-40000	托架 bracket	1
15	01010-52045	螺栓 bolt	6
16	01643-32060	加厚垫圈 washer	6
17	01010-52050	螺栓 bolt	4
18	01602-22060	垫圈 washer	4
19	01643-32060	加厚垫圈 washer	4
20	07000-05150	O 型圈 O-ring	1
21	23Y-04-00005	盖 cover	1
22	01602-21236	垫圈 washer	6
23	01010-51230	螺栓 bolt	6
24	23Y-04-00003	接头 joint	1

第109图 燃油管路
FIG.109 FUEL PIPING

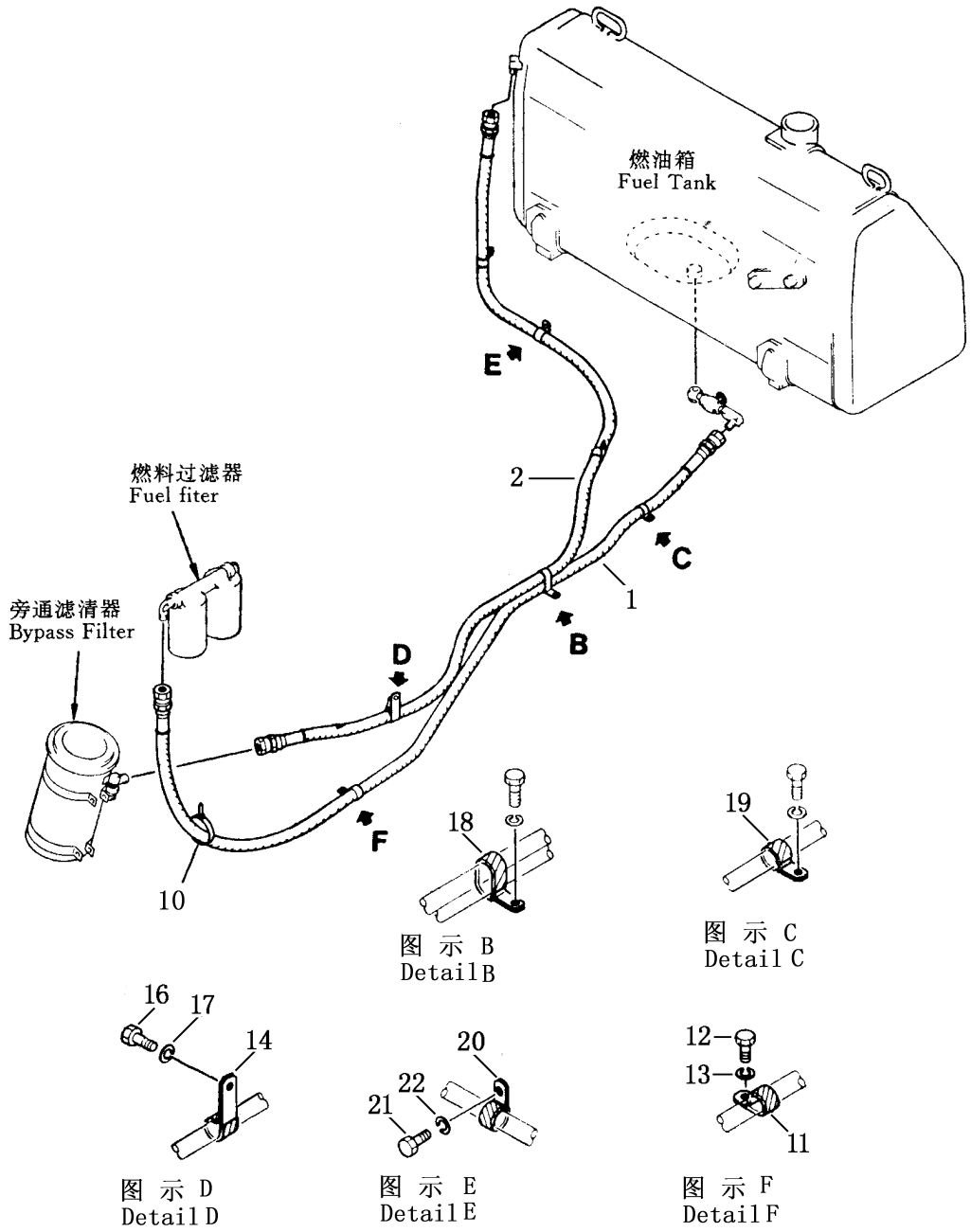

燃 油 管 路
FUEL PIPING

序号 Index No.	图 号 PART NO.	名 称 DESCRIPTION	数量 Q`TY
109-1	23Y-04-30000	进油管 hose	1
2	23Y-04-20000	回油管 hose	1
10	08034-00519	箍 clamp	1
11	08036-02514	管夹 clip	1
12	01010-51220	螺栓 bolt	1
13	01602-21236	垫圈 washer	1
14	195-01-12520	夹子 clip	1
16	01010-51020	螺栓 bolt	1
17	01602-21030	垫圈 washer	1
18	23Y-04-60000	夹子 clip	2
19	08036-02514	管夹 clip	1
20	23Y-04-10000	管夹 clip	3
21	01010-51020	螺栓 bolt	3
22	01602-21030	垫圈 washer	3

第110图 排气管及消音器
FIG.110 EXHAUST MANIFOLD AND MUFFLER

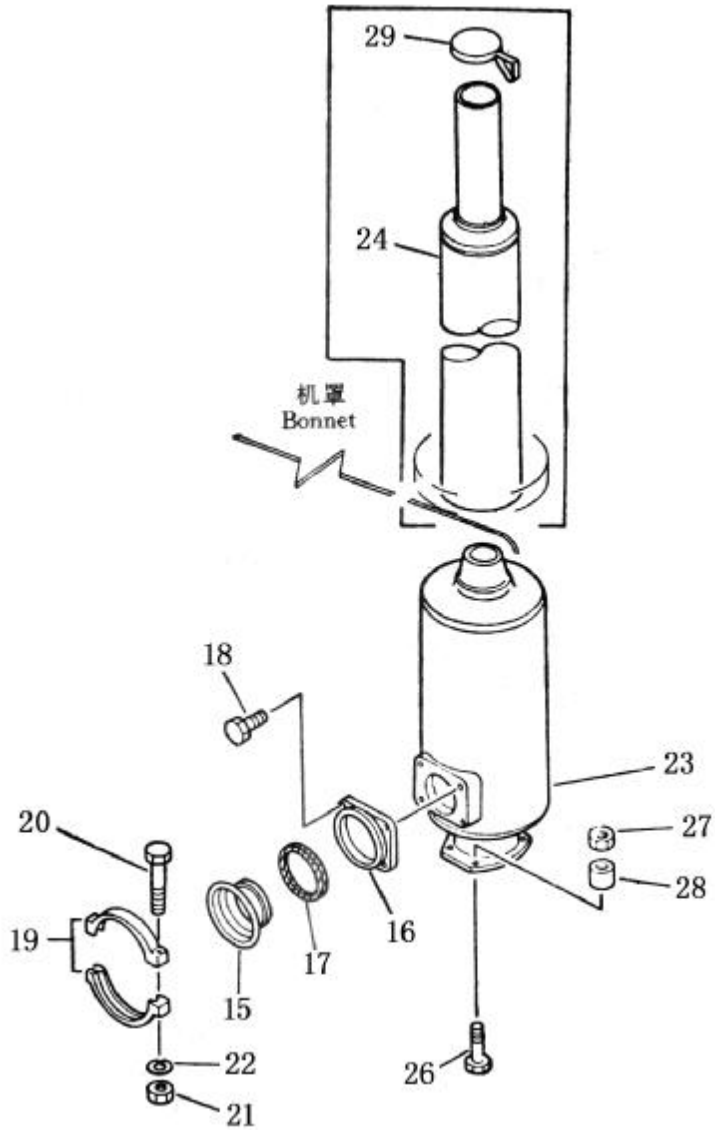

排气管及消音器
EXHAUST MANIFOLD AND MUFFLER

序号 Index No.	图 号 PART NO.	名 称 DESCRIPTION	数量 Q`TY
110-15	6631-11-5820	管接头 joint	1
16	6693-12-5530	凸缘 flange	1
17	6112-13-5250	密封环 ring, seal	1
18	01020-01030	螺栓 bolt	4
19	6657-11-5590	箍带 band	2
20	01010-80870	螺栓 bolt	2
21	01580-00806	螺帽 nut	2
22	01602-20285	垫圈 washer	2
23	6711-11-5711	消音器 muffler	1
24	6711-11-5750	排气管 pipe, exhaust	1
26	01050-61265	螺栓 bolt	4
27	01582-01210	螺帽 nut	4
28	6678-51-9520	衬垫 spacer	4
29	6711-11-5781	防雨帽 cap, rain	1

第 111 图 飞轮壳总成
FIG.111 FLYWHEEL HOUSING ASS'Y

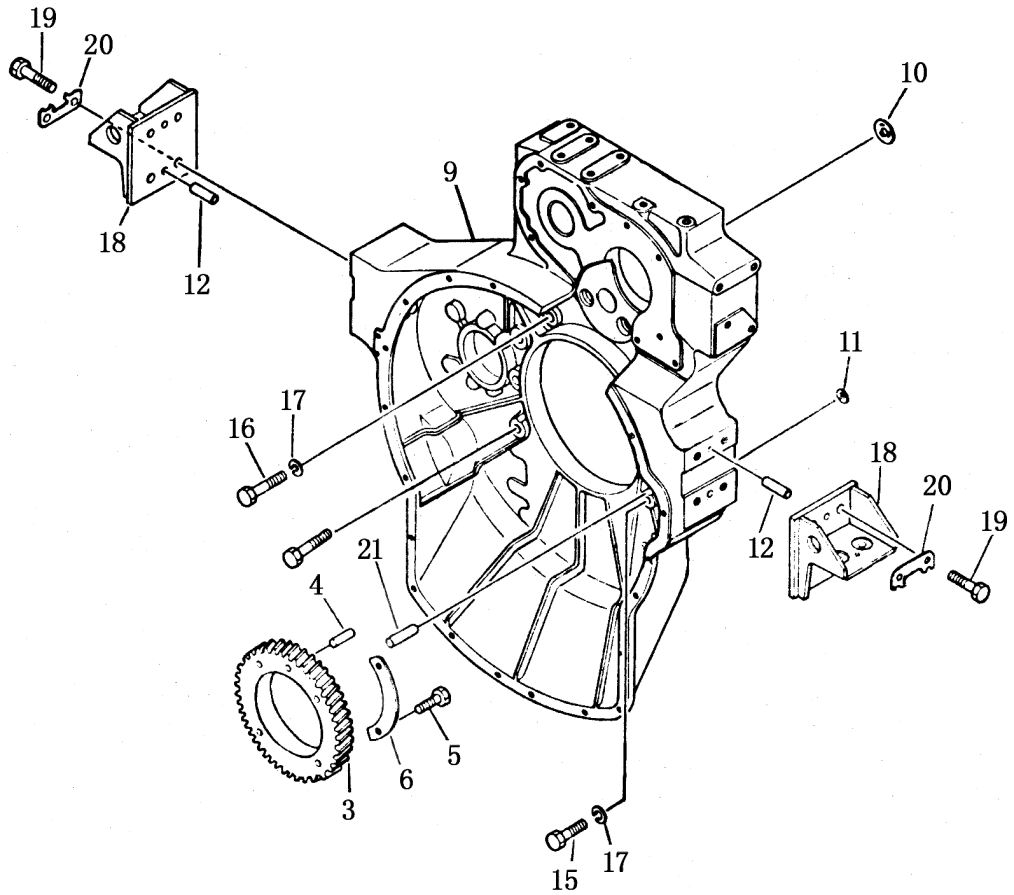

飞 轮 壳 总 成
FLYWHEEL HOUSING ASS'Y

序号 Index No.	图 号 PART NO.	名 称 DESCRIPTION	数量 Q`TY
	6711-21-C010	飞轮罩总成 flywheel housing ass' y	1
111-3	6623-31-1371	传动齿轮泵 gear, pump drive	1
4	6623-31-1390	定位销 pin, dowel	1
5	01010-31255	螺栓 bolt	4
6	6623-31-1380	锁板 plate, lock	2
9	6710-23-4110	飞轮罩 flywheel housing	1
10	07046-15520	膨胀塞 plug, expansion	1
11	07046-12016	膨胀塞 plug, expansion	4
12	04020-01434	定位销 pin, dowel	4
13	07042-00415	放泻塞 plug, drian	1
15	6710-23-4130	螺栓 bolt	5
16	6710-23-4120	螺栓 bolt	2
	6710-23-4140	螺栓 bolt	2
17	6600-01-2740	垫圈 washer	9
18	6691-23-4710	后支架 bracket, rear	2
19	01010-61845	螺栓 bolt	8
20	6643-21-4731	锁板 plate, lock	4
21	6711-21-C010	飞轮罩与气 缸体的定位销 pin, dowel, flywheel housing to cylinder block	2

第 112 图 出力装置
FIG.112 POWER TAKE OFF

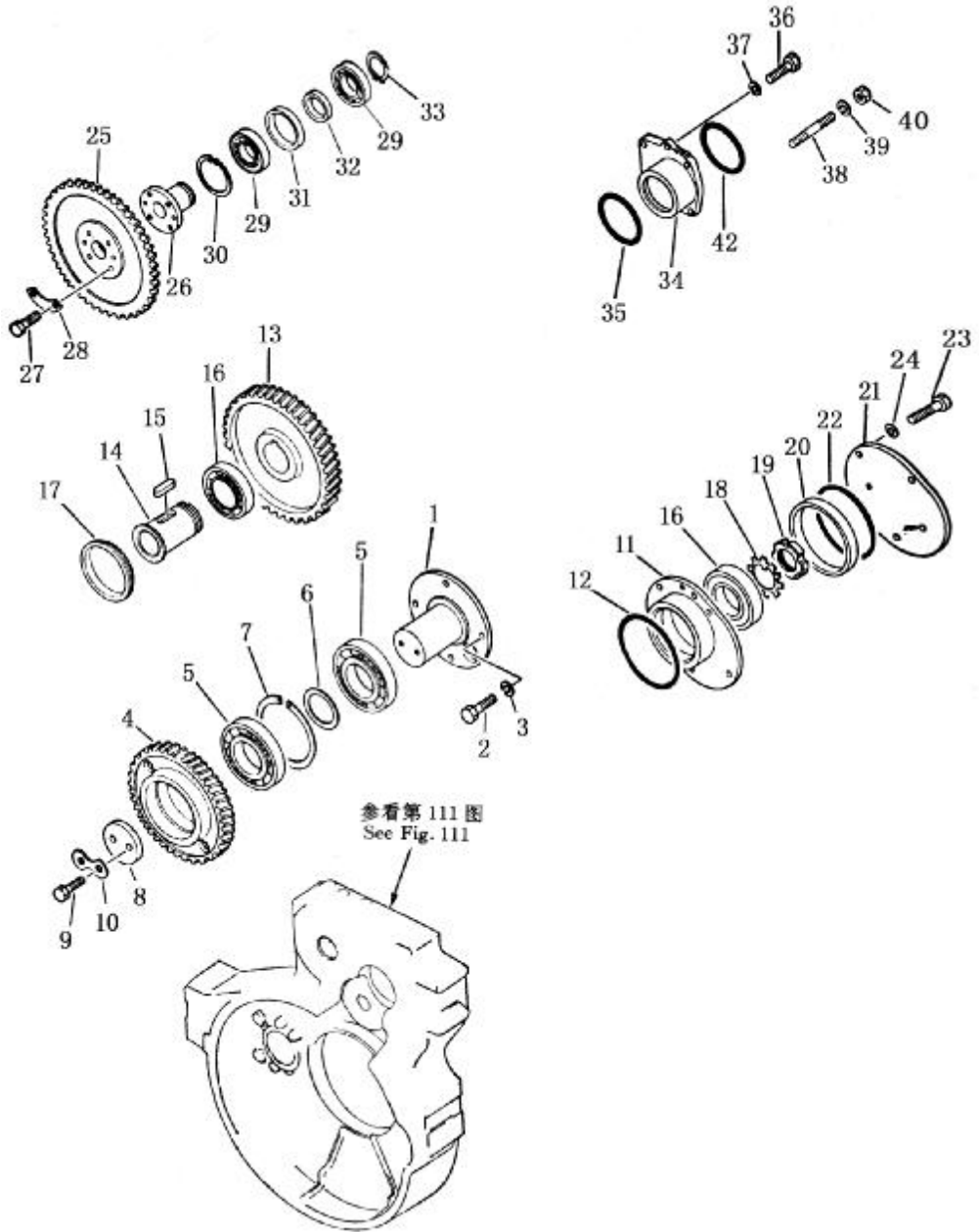

出力装置
POWER TAKE OFF

序号 Index No.	图号 PART NO.	名称 DESCRIPTION	数量 Q`TY
112-1	6691-21-4310	惰轮轴 shaft, idler gear	1
2	01010-31435	螺栓 bolt	4
3	01602-01442	垫圈 washer	4
4	6691-21-4321	惰轮 gear, idler, pump drive	1
5	06030-06310	径向球轴承 bearing, radial ball	2
6	6623-21-4330	衬垫 spacer	1
7	6623-21-4350	开口环 ring, snap	1
8	6623-21-4340	垫板 plate	1
9	01050-31230	螺栓 bolt	2
10	6623-21-4360	锁板 plate, lock	1
11	6691-21-4120	轴承罩 case, bearing	1
12	07000-03145	O型圈 o-ring	1
13	6691-21-4160	泵传动齿轮 gear, pump drive	1
14	6691-21-4170	泵传动轴 shaft, pump drive	1
15	04000-01850	键 key	1
16	06000-06214	径向球轴承 bearing, radial ball	2
17	6691-21-4190	定位环 ring, dowel	1
18	01658-26823	止动垫圈 washer, lock	1
19	01530-06814	螺帽 nut	1
20	6691-21-4130	衬垫 spacer	1
21	6691-21-4140	盖 cover	1
22	07000-03140	O型圈 o-ring	1
23	01010-31035	螺栓 bolt	5
24	01602-01030	垫圈 washer	5
25	6710-23-4520	泵传动齿轮 gear, pump drive	1
26	6691-23-4311	轴 shaft	1
27	01050-31020	螺栓 bolt	4
28	6645-22-4550	锁板 plate, lock	2
29	06000-06009	径向球轴承 bearing, radial ball	2
30	04065-07525	开口环 ring, snap	1
31	6691-21-4540	衬垫(A) spacer	1
32	6691-21-4560	衬垫(B) spacer	1

出力装置
POWER TAKE OFF

序号 Index No.	图 号 PART NO.	名 称 DESCRIPTION	数量 Q`TY
112-33	04064-04518	开口环 ring, snap	1
34	6711-21-C120	轴承壳 case, bearing	1
35	07000-03100	O 型圈 o-ring	1
36	01010-31045	螺栓 bolt	2
37	01602-01030	垫圈 washer	2
38	01140-51235	双头螺栓 stud bolt	4
39	01602-21236	垫圈 washer	4
40	01582-11210	螺帽 nut	4
42	07000-62085	O 型圈 o-ring	1

第113图 出力装置润滑油管
 FIG.113 P.T.O. LUBRICATING OIL PIPING

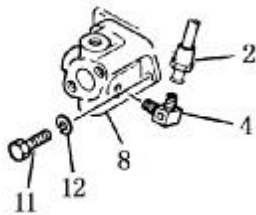
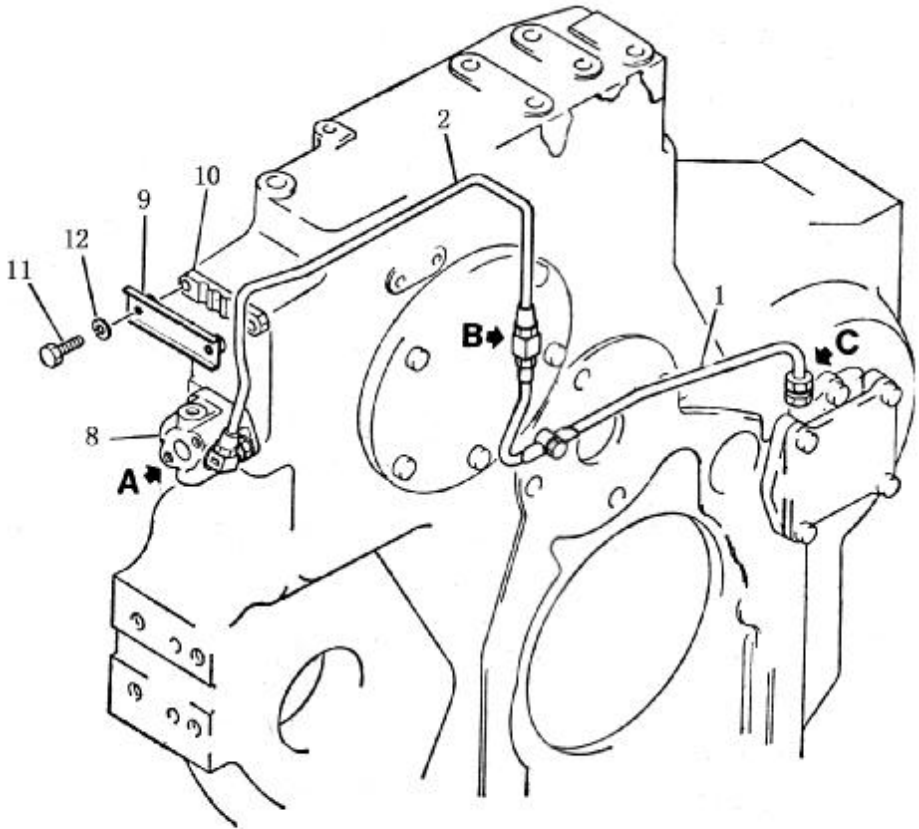

图示 A
 Detail A

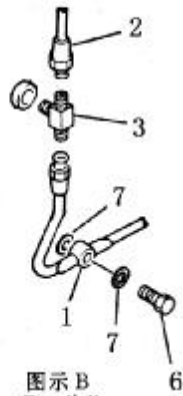

图示 B
 Detail B

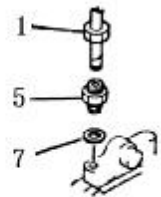

图示 C
 Detail C

出力装置润滑油管
P.T.O. LUBRICATING OIL PIPING

序号 Index No.	图 号 PART NO.	名 称 DESCRIPTION	数量 Q`TY
113-1	6691-53-9510	管 pipe	1
2	6691-51-9521	管 pipe	1
3	6691-51-9570	“T”型管接头 tee joint	1
4	07217-00610	弯头 elbow	1
5	6691-51-9580	连接器 connector	1
6	6600-01-3860	螺栓 bolt	1
7	07003-01015	填密垫 gasket	3
8	6691-51-9560	分配器 flange	1
9	6600-01-5930	夹板 clamp	1
10	6691-51-9540	夹板 clamp	1
11	01010-31030	螺栓 bolt	4
12	01602-01030	垫圈 washer	4

第 114 图 前 支 架
 FIG.114 FRONT SUPPORT

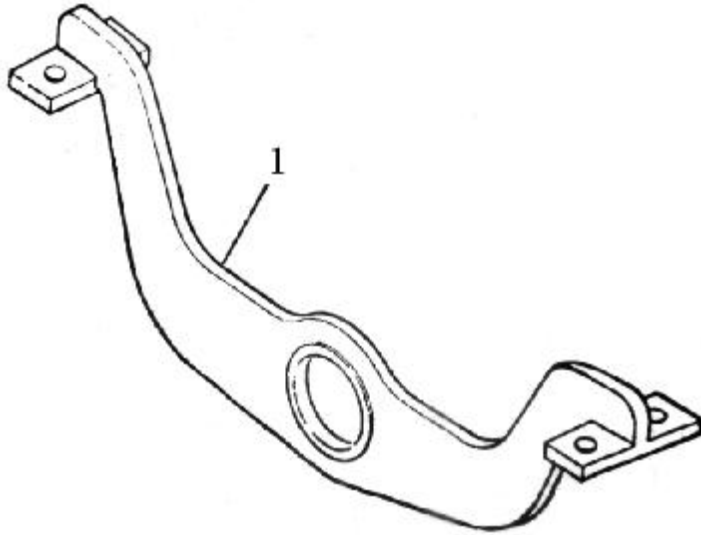

前 支 架
 FRONT SUPPORT

序号 Index No.	图 号 PART NO.	名 称 DESCRIPTION	数量 Q`TY
114-1	6711-21-3711	前支架 support, front	1

第 115 图 空气滤清器及罩
 FIG.115 AIR CLEANER AND CAP

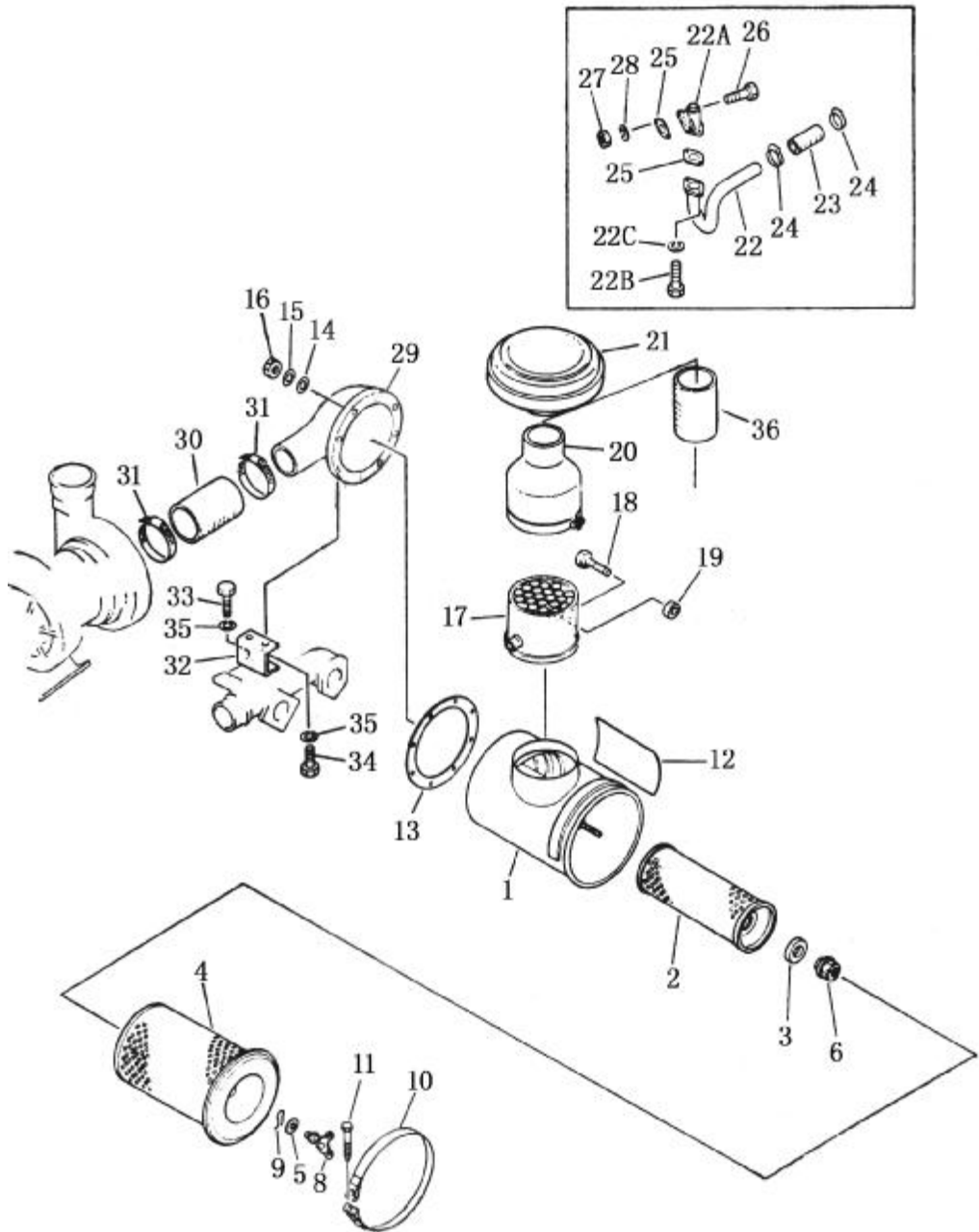

空气滤清器及罩
AIR CLEANER AND CAP

序号 No.	图 号 PART NO.	名 称 DESCRIPTION	数量 Q' TY		
			SD22, SD22E, SD22S	SD22D	
	(6127-82-7106)	空气滤清器总成	air cleaner ass' y	1	1
115-1	6127-82-7115	空气滤清器主体	body, cleaner	1	1
2	6127-81-7412	内芯组件	element, inner	1	1
3	600-181-7511	螺母	nut	1	1
4	6128-81-7320	外芯组件	element, outer	1	1
5	600-181-4440	密封垫圈	washer, seal	1	1
6	600-181-4370	螺母	nut	1	1
8	600-181-4420	蝶形螺栓	bolt, butterfly	1	1
9	600-181-4430	夹	clip	1	1
10	6127-11-4360	箍带	hoop-band	1	1
11	6643-11-4641	螺栓	bolt	1	1
12	09637-00160	铭牌	data plate	1	1
13	6127-81-4821	密封垫	gasket	1	1
14	01640-21016	垫圈	washer	8	8
15	01602-01030	弹簧垫圈	washer spring	8	8
16	01580-01008	螺母	nut	8	8
17	6090-01-4250	粗滤器总成	precleaner ass' y	1	1
18	01016-31045	螺栓	bolt	1	1
19	01580-01008	螺母	nut	1	1
20	6711-81-7920	连接器	connector	1	
	22M-06-30000	连接器	connector		1
21	600-181-1510	帽	cap	1	
	22M-06-10000	帽	cap		1
22	6711-11-4770	连接管	pipe, ejector	1	1
22A	6128-11-5302	止回阀部件	valve ass' y	1	1
22B	01010-31025	螺栓	bolt	2	2
22C	01602-01030	弹簧垫圈	washer spring	2	2
23	6127-11-4780	软管	hose	1	1
24	07281-00498	软管夹	clamp	2	2
25	6128-11-5610	密封垫	gasket	2	2
26	01010-31035	螺栓	bolt	2	2
27	01580-01008	螺母	nut	2	2
28	01602-01030	弹簧垫圈	washer spring	2	2
29	6711-11-4210	空气连接器	air, connector	1	1
30	6691-11-4740	软管	hose	1	1
31	07281-01659	软管头	clamp	2	2
32	6711-11-4530	空气连接器托架	bracket, air connector	1	1
33	01010-31230	螺栓	bolt	2	2
34	01010-31235	螺栓	bolt	2	2
35	01602-01236	弹簧垫圈	washer spring	4	4
36	22M-06-00003	软管	hose		1

第 116 图 风扇
 FIG.116 FAN

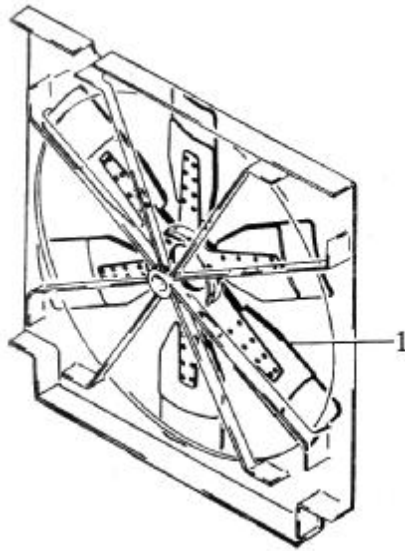

风扇
 FAN

序号 Index No.	图 号 PART NO.	名 称 DESCRIPTION	数量 Q`TY
116-1	600-643-1060	风扇 fan	1

液力变矩器、变速箱及管路

TORQUE CONVERTER, TRANSMISSION CASE
AND PIPING

第 201 图 万 向 节
FIG. 201 UNIVERSAL JOINT

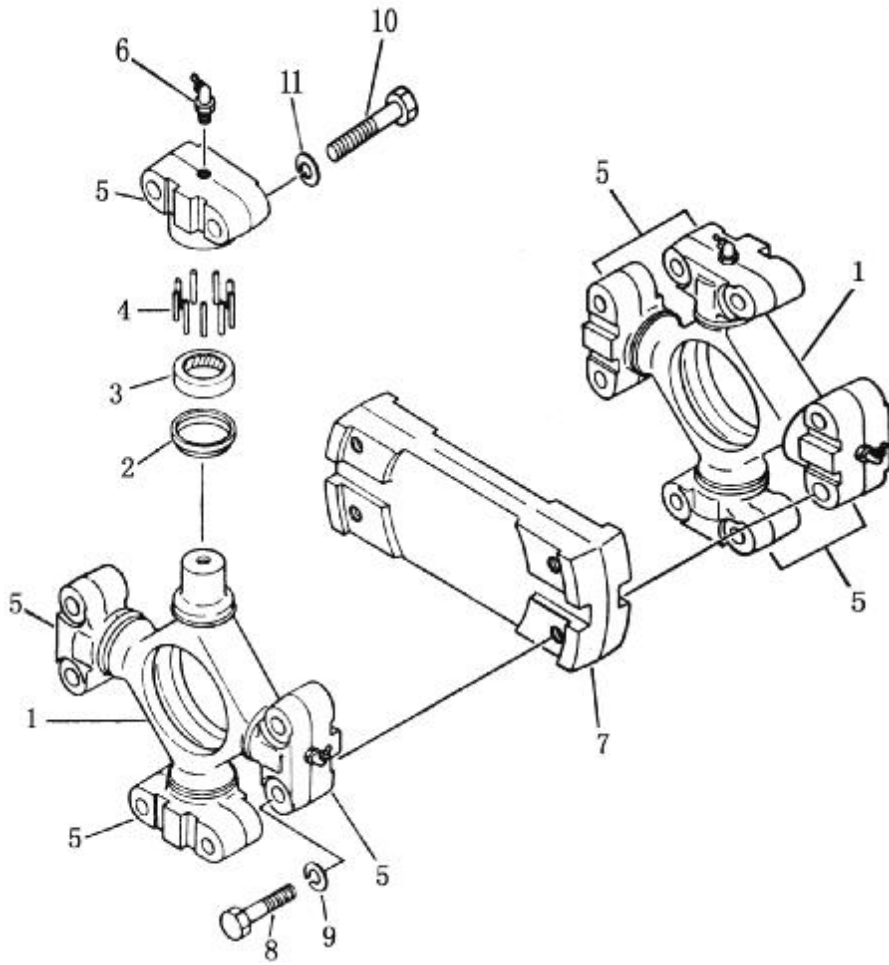

万 向 节 UNIVERSAL JOINT

序 号 INDEXNO.	图 号 PART NO.	名 称 DESCRIPTION	数量 Q`TY
	(154-20-10002)	万向节总成 universal joint ass' y	1
	(154-20-11100)	十字轴总成 spider ass' y	2
201-1	150-11-11210	十字轴 spider	2
2	150-11-11220	防尘封 seal, dust	8
3	150-11-11250	油封 seal, oil	8
4	150-11-11240	滚针 needle	296
5	154-20-11130	轴承壳 case, bearing	8
6	07020-00000	油脂咀 fitting, grease	8
7	154-20-11170	连接板 coupling plate	1
8	01010-51255	螺栓 bolt	8
9	01602-21236	弹簧垫圈 washer, spring	8
10	01010-51260	螺栓 bolt	8
11	01602-21236	弹簧垫圈 washer, spring	8

第202图 液力变矩器壳
 FIG.202 TORQUE CONVERTER HOUSING

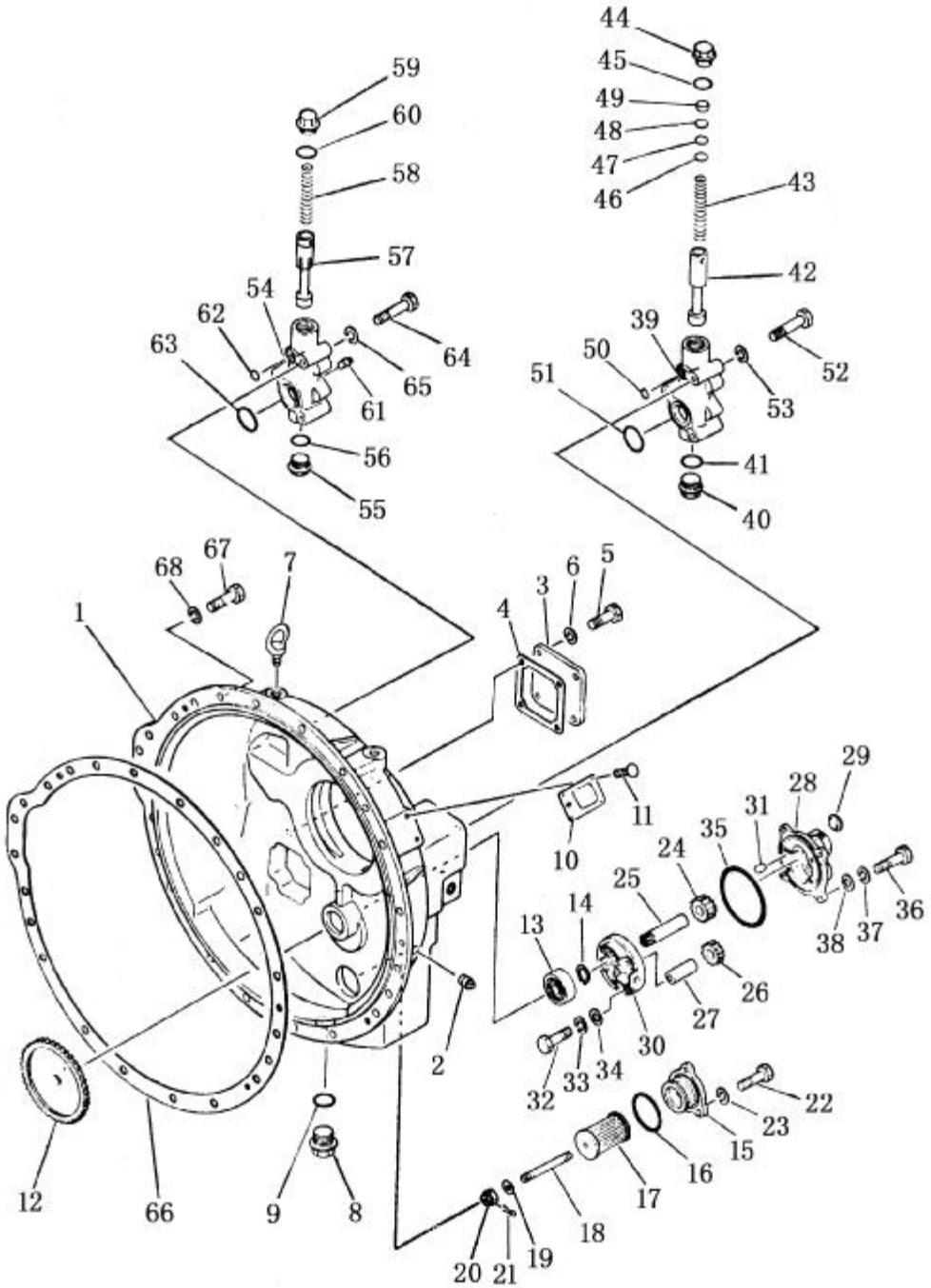

液力变矩器壳

TORQUE CONVERTER HOUSING

序号 INDEXNO.	图号 PART NO.	名称 DESCRIPTION	数量 Q`TY
	23Y-11B-00000	液力变矩器总成 torque converter ass' y 本总成所构成的配件是包括在第 202 图及第 203 图所列的全部配件 This assembly consists of parts shown in Fig, 202 and Fig, 203.	1
202-1	154-13-53110	壳 housing	1
2	07042-20415	圆锥形(插)塞 plug, taper	3
3	175-13-23220	盖 cover	1
4	175-13-23231	填密垫 gasket	1
5	01010-81225	螺栓 bolt	4
6	01602-21236	弹簧垫圈 washer, spring	4
7	04530-11628	吊环螺栓 bolt, eye	2
8	07044-13620	磁性螺塞 plug, magnetic	1
9	07002-43634	O 型圈 o-ring	1
10	14Y-11-00038	铭牌 plate, name	1
11	04418-03060	自攻螺钉 screw, tapping	4
12	195-13-14111	齿轮 gear	1
13	06030-05206	轴承 bearing	1
14	04064-03015	开口环 ring, snap	1
	(134-13-13400)	过滤器总成 filter ass' y	1
15	134-13-13410	盖 cover	1
16	07000-62070	O 型圈 o-ring	1
17	195-13-13420	过滤器 filter	1
18	134-13-13430	双头螺栓 stud	1
19	01641-20608	垫圈 washer	1
20	01590-10607	螺帽 nut	1
21	04050-11212	开口销 pin, cotter	1
22	01010-81230	螺栓 bolt	3
23	01602-21236	弹簧垫圈 washer, spring	3
	(175-13-23500)	回油泵总成 scavenging pump ass' y	1
24、25	175-13-23510	传动齿轮总成 drive gear ass' y	1
26、27	175-13-23520	从动齿轮总成 driven gear ass' y	1
28	175-13-23530	箱总成 case ass' y	1
29	01190-01011	螺纹衬套 helisert	2
30	175-13-23540	盖 cover	1
31	04020-00820	定位销 pin, dowel	2
32	01010-80835	螺栓 bolt	4

液力变矩器壳

TORQUE CONVERTER HOUSING

序号 INDEXNO.	图号 PART NO.	名称 DESCRIPTION	数量 QTY
33	01602-20825	垫圈 washer	4
34	01641-20812	垫圈 washer	4
35	07000-62115	O型圈 o-ring	1
36	01010-81235	螺栓 bolt	4
37	01602-21236	垫圈 washer	4
38	01641-21223	垫圈 washer	4
	(195-13-16100)	安全阀总成 relief valve ass'y	1
39	195-13-16110	安全阀阀体 body, relief valve	1
40	195-13-16450	螺塞 plug	1
41	07002-43634	O型圈 o-ring	1
42	195-13-16120	安全阀阀柱 spool, relief valve	1
43	195-13-16131	安全阀弹簧 spring, relief valve	1
44	195-13-16141	螺塞 plug	1
45	07002-43634	O型圈 o-ring	1
46	195-13-16190	填片 shim	1
47	195-13-16210	填片 shim	1
48	195-13-16220	填片 shim	1
49	195-13-16230	衬垫 spacer	1
50	07000-72018	O型圈 o-ring	1
51	07000-73045	O型圈 o-ring	1
52	01010-81290	螺栓 bolt	1
53	01602-21236	垫圈 washer	1
	(175-13-26401)	调节阀总成 regulator valve ass'y	1
54	175-13-26410	调节阀阀体 body, regulator valve	1
55	195-13-16450	螺塞 plug	1
56	07002-43634	O型圈 o-ring	1
57	195-13-16420	调节阀阀柱 spool, regulator valve	1
58	195-13-16430	调节阀弹簧 spring, regulator valve	1
59	195-13-16141	螺塞 plug	1
60	07002-43634	O型圈 o-ring	1
61	07042-20108	圆锥形(插)塞 plug, taper	1
62	07000-72018	O型圈 o-ring	1
63	07000-73045	O型圈 o-ring	1
64	01010-81295	螺栓 bolt	3
65	01602-21236	垫圈 washer	3
66	175-11-11111	填密垫 gasket	1
67	01010-81240	螺栓 bolt	23
68	01602-21236	垫圈 washer	23

第 203 图 涡轮轴和导轮
 FIG.203 TURBINE SHAFT AND STATOR

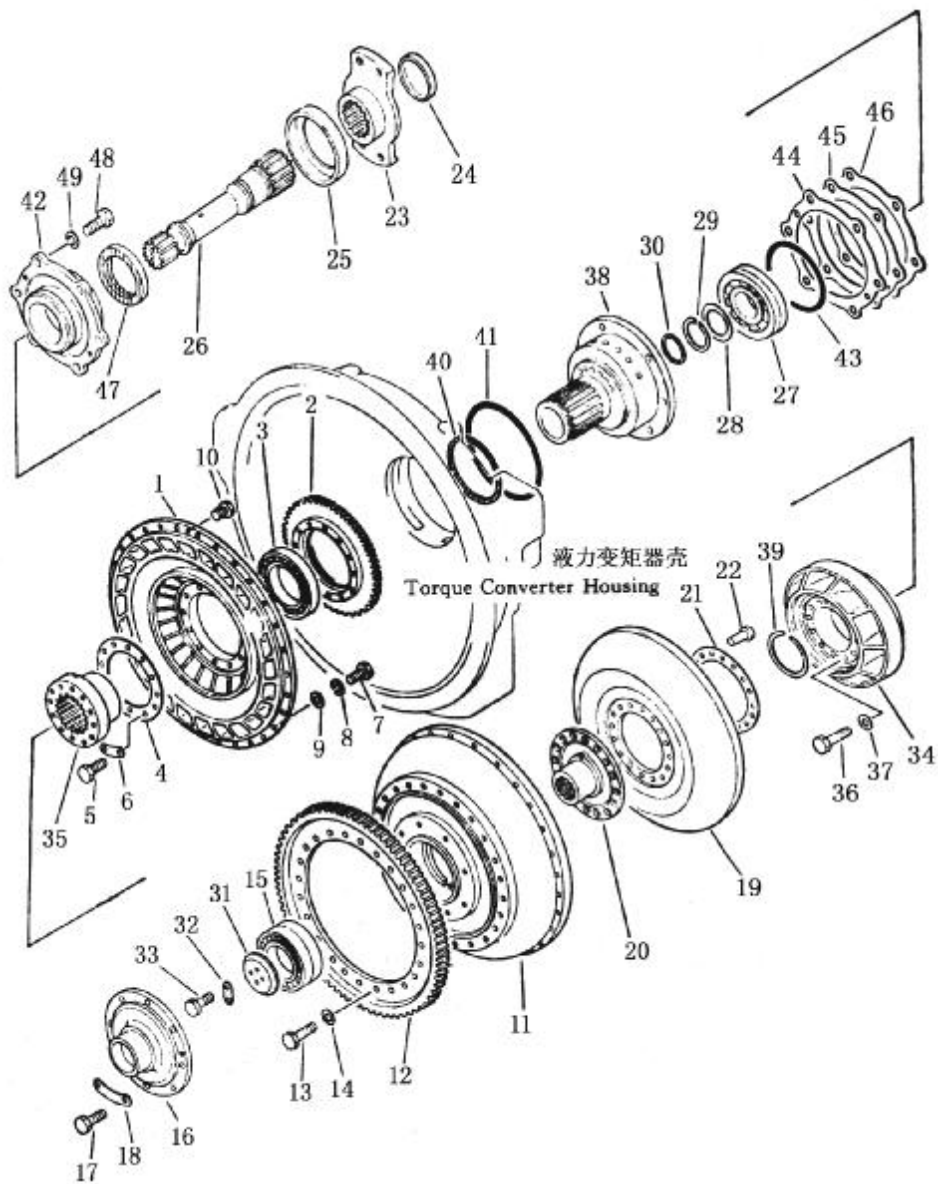

涡轮轴和导轮

TURBINE SHAFT AND STATOR

序 号 INDEX NO.	图 号 PART NO.	名 称 DESCRIPTION	数量 Q`TY
	(154-13—41002)	液力变矩器总成 torque converter ass' y 这总成所构成的配件是包括在第 202 图 及第 203 图所载的全部配件 The assembly consists of all parts shown in Fig.202 and Fig.203.	1
203-1	154-13-41123	泵轮 pump	1
2	154-13-41141	齿轮 gear	1
3	154-13-41160	轴承 bearing	1
4	154-13-41180	垫板 plate	1
5	01010-81035	螺栓 bolt	12
6	154-13-41150	锁板 plate, lock	6
7	01010-81035	螺栓 bolt	30
8	01602-21030	弹簧垫圈 washer, spring	30
9	01643-31032	垫圈 washer	30
10	07040-11007	螺塞 plug	2
	(154-13-00011)	箱总成 case ass' y	1
11	234-13-11211	壳 case	1
12	175-13-21220	齿轮 gear	1
13	01010-81230	螺塞 plug	24
14	01643-31232	垫圈 washer	24
15	154-13-11240	轴承 bearing	1
16	234-13-11250	导向器 pilot	1
17	01010-81230	螺塞 plug	8
18	195-13-11261	锁板 plate, lock	4
19, 20, 21, 22	(154-13-41510)	涡轮总成 turbo ass' y	1
23, 24, 25	(154-13-41660)	联轴节总成 coupling joint ass' y	1
26	154-13-41651	轴 shaft	1
27	154-13-13360	轴承 bearing	1
28	154-13-11730	衬垫 spacer	1

涡轮轴和导轮

TURBINE SHAFT AND STATOR

序 号 INDEX NO.	图 号 PART NO.	名 称 DESCRIPTION	数量 Q`TY
203-29	04064-06020	开口环 ring, snap	1
30	175-13-21720	密封环 ring, seal	1
31	175-13-21691	压板 plate	1
32	175-13-21711	锁板 plate, lock	1
33	175-13-21810	铰制孔螺栓 bolt, reamer	2
34	154-13-42110	导轮 stator	1
35	154-13-42120	座圈 race	1
36	01010-81030	螺栓 bolt	12
37	01643-31032	垫圈 washer	12
38	154-13-52520	轴 shaft	1
39	04064-08025	开口环 ring, snap	1
40	154-13-42710	密封环 ring, seal	1
41	07000-65190	O 型圈 o-ring	1
42	154-13-42720	盖 cover	1
43	07000-62130	O 型圈 o-ring	1
44	195-13-11610	垫片 shim	1
45	195-13-11620	垫片 shim	1
46	195-13-11630	垫片 shim	1
47	175-13-22760	油封 seal, oil	1
48	01010-81240	螺栓 bolt	6
49	01602-21236	弹簧垫圈 washer, spring	6

第 204 图 变速箱壳
 FIG. 204 TRANSMISSION CASE

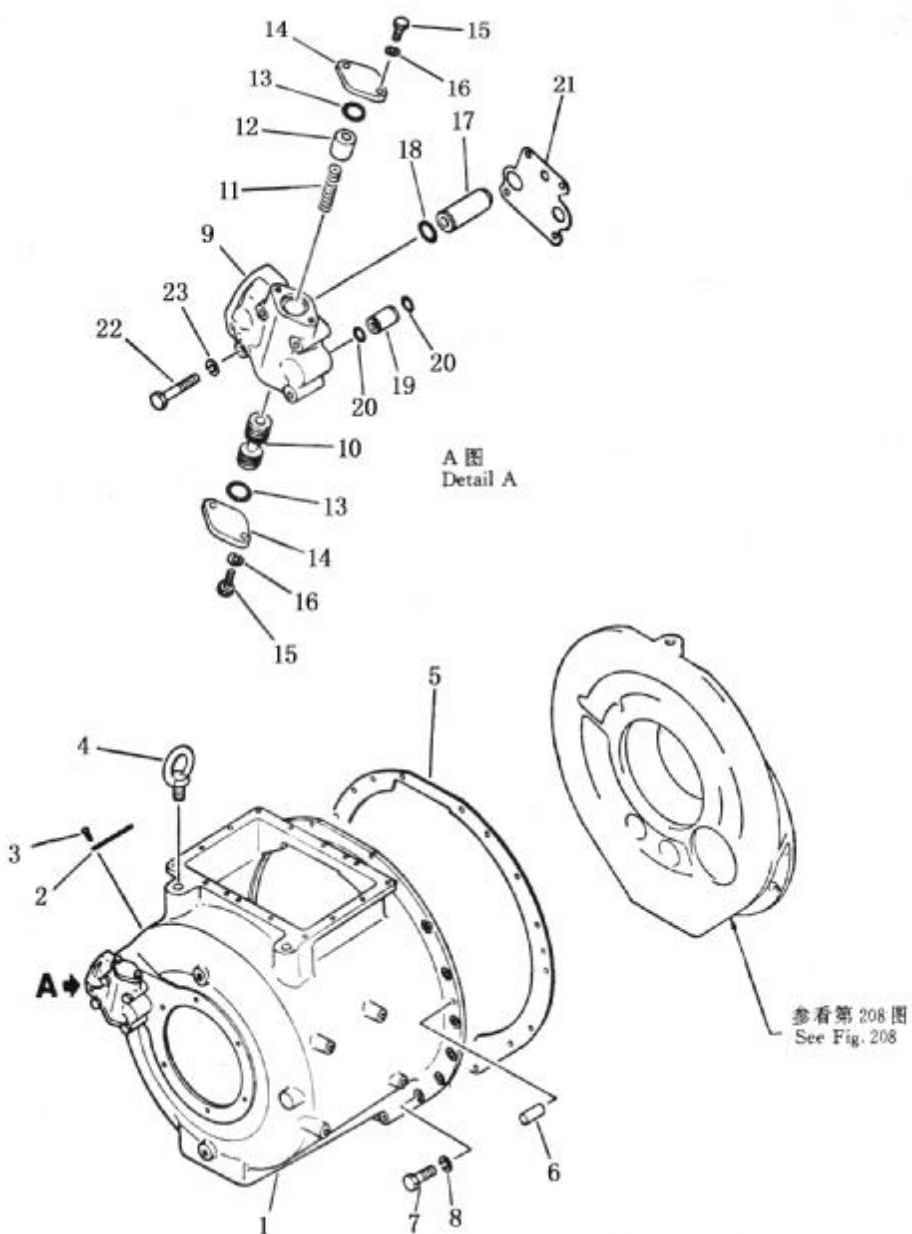

变 速 箱 壳

TRANSMISSION CASE

序 号 INDEXNO.	图 号 PART NO.	名 称 DESCRIPTION	数量 Q' TY
	(154-13-31000)	变速箱总成 torqueflow transmission ass' y 该总成所构成的配件是在第 204 图至第 211 图所载的全部配件 This assembly consists of parts shown in Fig.204 to 211.	1
204-1	154-15-21111	箱体 case	1
2	09608-05080	铭牌 plate, name	1
3	04418-03060	铆钉 rivet	4
4	04530-02438	吊环螺栓 bolt, eye	2
5	154-15-21121	密封垫 gasket	1
6	04020-01228	定位销 pin, dowel	1
7	01010-51240	螺栓 bolt	15
8	01602-21236	垫圈 washer	15
	(154-15-34000)	润滑阀总成 lubrication valve ass' y	1
9	154-15-24110	阀体 body	1
10	175-15-14130	阀 valve	1
11	175-15-14120	弹簧 spring	1
12	175-15-14141	导向套 guide	1
13	07000-63032	O 型圈 o-ring	2
14	175-15-14150	盖 cover	2
15	01010-50825	螺栓 bolt	4
16	01602-20825	垫圈 washer	4
17	154-15-34170	套筒 sleeve	1
18	07000-62018	O 型圈 o-ring	1
19	175-15-44180	套筒 sleeve	1
20	07000-62018	O 型圈 o-ring	2
21	175-15-14161	密封垫 gasket	1
22	01010-51065	螺栓 bolt	4
23	01602-21030	垫圈 washer	4

第 205 图 变速箱齿轮和轴 (1/3)
FIG. 205 TRANSMISSION GEAR AND SHAFT

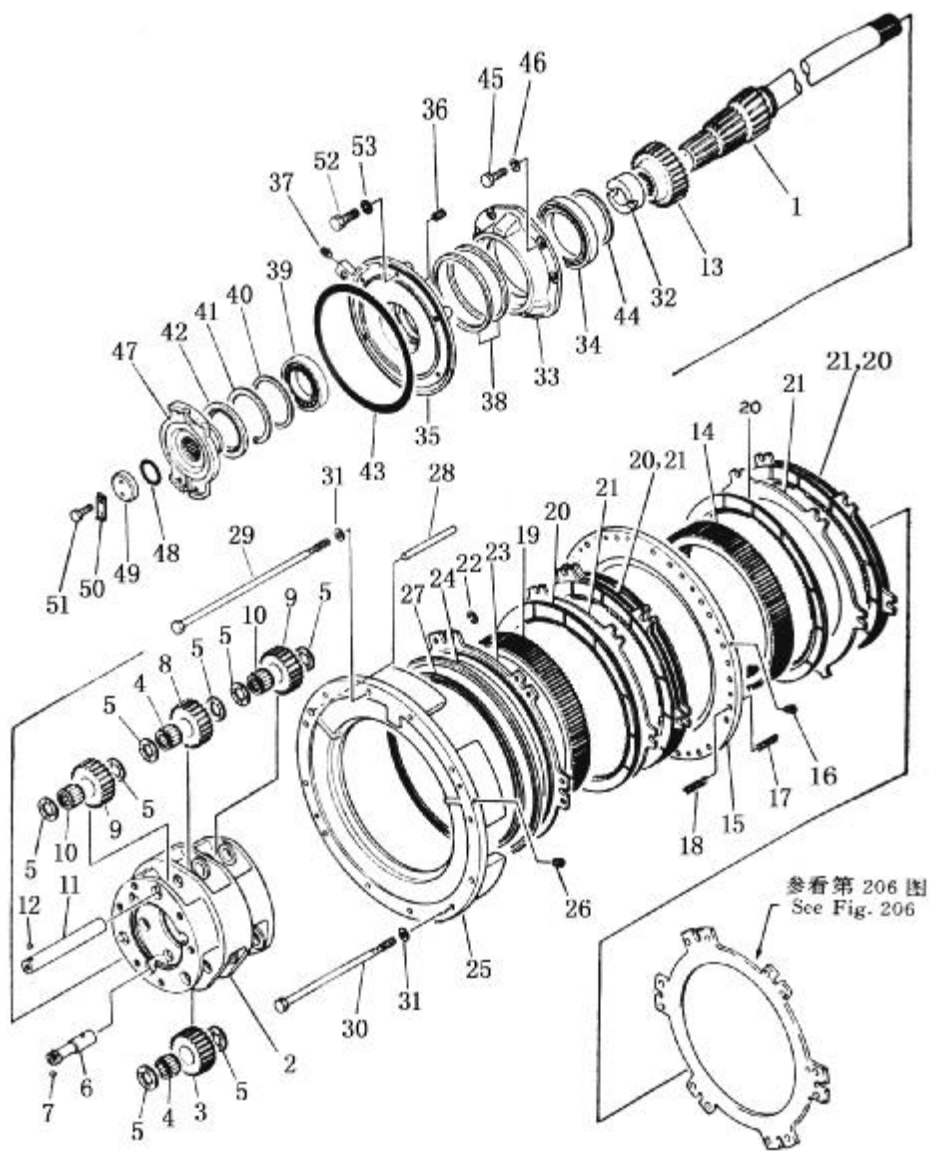

变速箱齿轮和轴 (1/3)

TRANSMISSION GEAR AND SHAFT

序 号 INDEXNO.	图 号 PART NO.	名 称 DESCRIPTION	数量 Q`TY
205-1	154-15-32110	轴 shaft	1
2	154-15-32320	行星架 carrier	1
3	154-15-32470	齿轮 gear	3
4	154-15-39120	轴承 bearing	6
5	09233-05125	止推垫圈 washer, thrust	24
6	154-15-32530	轴 shaft	3
7	04260-00635	钢珠 ball	3
8	154-15-32460	齿轮 gear	3
9	154-15-32450	齿轮 gear	6
10	09232-05138	轴承 bearing	6
11	154-15-32510	轴 shaft	3
12	04260-00635	钢珠 ball	3
13	154-15-32120	齿轮 gear	1
14	155-15-12620	齿圈 gear, ring	1
	154-15-00271	垫板总成 plate, ass' y	1
15	154-15-31170	垫板 plate	1
16	145-14-11320	螺塞 plug	2
17	154-15-22760	弹簧 spring	12
18	175-15-42780	弹簧 spring	12
19	154-15-32610	齿圈 gear, ring	1
20	175-15-12713	摩擦片 disk	7
21	175-15-42721	垫板 plate	5
22	175-15-42880	(垫圈型)弹簧 spring, washer-type	36
23	155-15-12892	活塞 piston	1
24	154-15-22811	密封环 ring, seal	1
	(154-15-00400)	套总成 housing ass' y	1
25	154-15-31180	油缸体 body	1
26	145-14-11320	螺塞 plug	2
27	155-15-12811	密封环 ring, seal	1
28	155-15-12770	销 pin	6
29	155-15-11191	螺栓 bolt	11

变速箱齿轮和轴 (1/3)

TRANSMISSION GEAR AND SHAFT

序号 INDEXNO.	图号 PART NO.	名称 DESCRIPTION	数量 Q`TY
205-30	155-15-11291	螺栓 bolt	1
31	145-14-11570	垫圈 washer	12
32	195-15-12141	衬垫 spacer	1
33	154-15-32310	轴承座 cage	1
34	06000-06924	轴承 bearing	1
	(154-15-00410)	套总成 cage ass'y	1
35	154-15-31210	壳体 cage	1
36	195-15-11230	螺塞 plug	1
37	07042-00211	螺塞 plug	1
38	07018-11805	密封环 ring, seal	2
39	06000-06016	轴承 bearing	1
40	04077-00125	开口环 ring, snap	1
41	195-15-11240	衬垫 spacer	1
42	07012-10100	密封 seal	1
43	07000-05290	O型圈 o-ring	1
44	04070-00120	开口环 ring, snap	1
45	01010-51230	螺栓 bolt	6
46	01602-21236	垫圈 washer	6
47	154-15-32150	联轴节 coupler	1
48	07000-65055	O型圈 o-ring	1
49	175-15-12160	托板 holder	1
50	04081-05512	锁片 lock	1
51	01010-51230	螺栓 bolt	2
52	01010-51235	螺栓 bolt	6
53	01602-21236	垫圈 washer	6

第 206 图 变速箱齿轮和轴 (2/3)
 FIG. 206 TRANSMISSION GEAR AND SHAFT

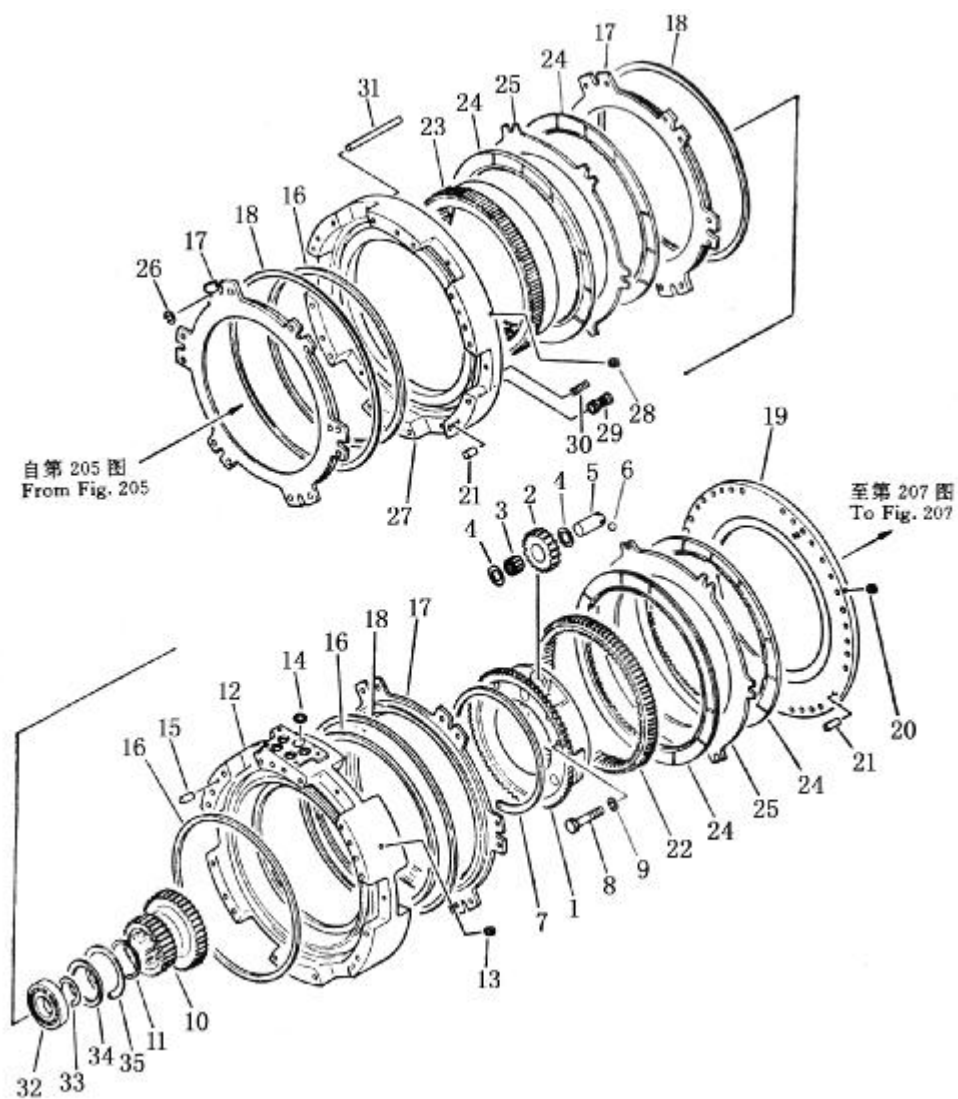

变速箱齿轮和轴 (2/3)

TRANSMISSION GEAR AND SHAFT

序 号 INDEXNO.	图 号 PART NO.	名 称 DESCRIPTION	数量 Q`TY
206-1	155-15-12363	行星架 carrier	1
2	154-15-32490	齿轮 gear	3
3	09232-03832	轴承 bearing	3
4	09233-03820	止推垫圈 washer, thrust	6
5	155-15-12551	轴 shaft	3
6	04260-00635	钢珠 ball	3
7	175-15-42670	卡环 ring, snap	1
8	01010-51470	螺栓 bolt	6
9	01602-21442	弹簧垫圈 washer, spring	6
10	154-15-32130	齿轮 gear	1
11	04064-08530	开口环 ring, snap	1
	(154-15-00251)	套总成 housing ass' y	1
12	155-15-11152	油缸体 body	1
13	145-14-11320	螺塞 plug	2
14	07000-63022	O型圈 o-ring	5
15	04020-01228	定位销 pin, dowel	2
16	155-15-12820	密封环 ring, seal	3
17	155-15-12880	活塞 piston	3
18	154-15-22811	密封环 ring, seal	3
	(154-15-00240)	垫板总成 plate ass' y	1
19	154-15-21140	垫板 plate	1
20	145-14-11320	螺塞 plug	2
21	175-15-31210	定位销 pin, dowel	4
22	155-15-12650	齿圈 gear ring	1
23	155-15-12632	齿圈 gear ring	1
24	175-15-12713	摩擦片 disk	4
25	175-15-42721	垫板 plate	2
26	175-15-42880	(垫圈型)弹簧 spring, washer type	30
	(154-15-00262)	套总成 housing ass' y	1
27	154-15-31160	油缸体 body	1
28	145-14-11320	螺塞 plug	2
29	09231-01430	套筒 sleeve	12

变速箱齿轮和轴 (2/3)

TRANSMISSION GEAR AND SHAFT

序号 INDEXNO.	图号 PART NO.	名称 DESCRIPTION	数量 Q`TY
206-30	154-15-22760	弹簧 washer	24
31	155-15-12770	销 pin	6
32	06042-00212	轴承 bearing	1
33	04064-06020	开口环 ring, snap	1
34	175-15-42340	挡油板 plate	1
35	130-09-15740	卡环 ring, snap	1

第 207 图 变速箱齿轮和轴 (3/3)
FIG. 207 TRANSMISSION GEAR AND SHAFT

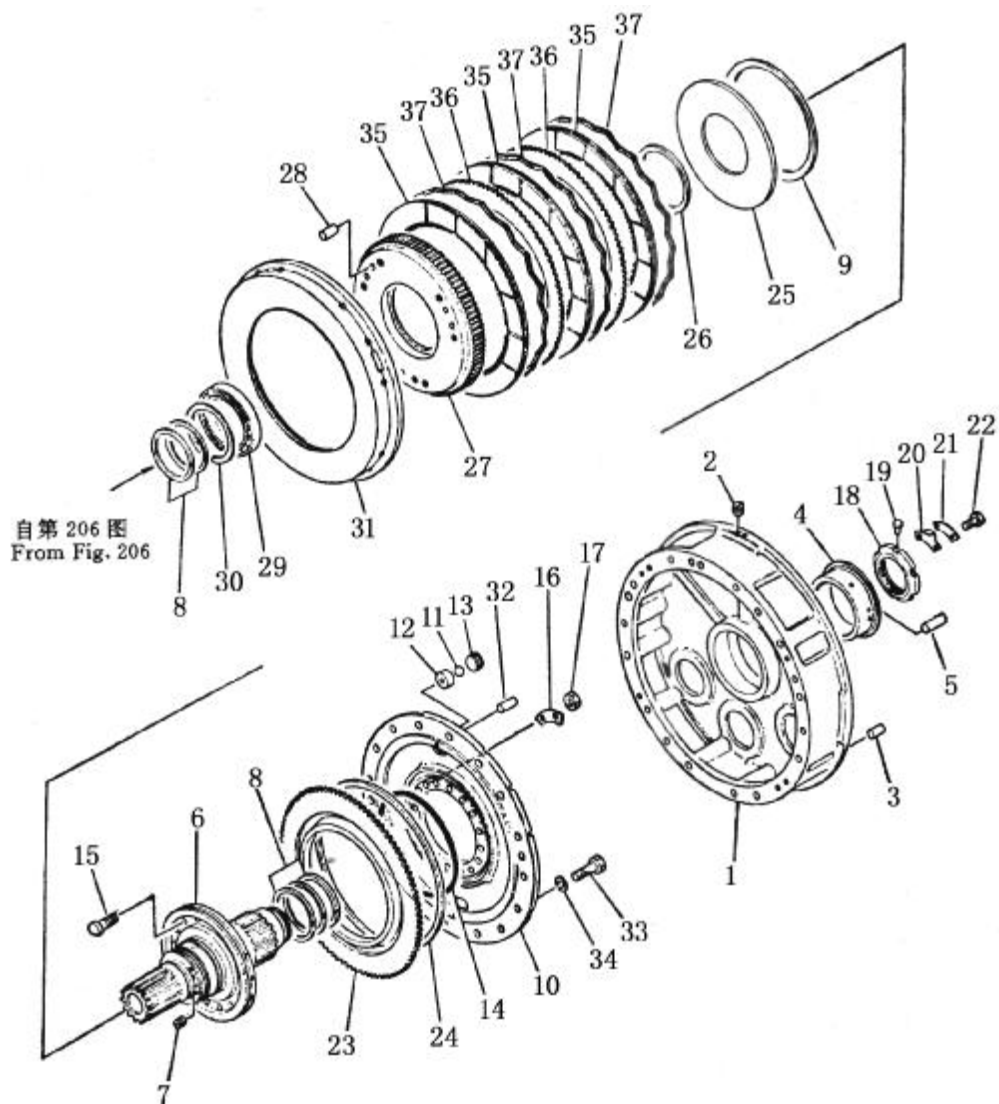

变速箱齿轮和轴 (3/3)

TRANSMISSION GEAR AND SHAFT

序 号 INDEXNO.	图 号 PART NO.	名 称 DESCRIPTION	数量 Q`TY	
	(154-15-00232)	套总成	housing ass' y	1
207-1	154-15-31130	壳	housing	1
2	234-15-12780	螺钉	screw	3
3	04020-01228	定位销	pin, dowel	2
4	175-15-41310	套环	collar	1
5	04020-00616	定位销	pin, dowel	1
	(154-15-00311)	轴总成	shaft ass' y	1
6	155-15-12212	轴	shaft	1
7	145-14-11320	螺塞	plug	8
8	175-15-42850	密封环	ring, seal	5
9	154-15-22831	密封环	ring, seal	1
	(155-15-00330)	套总成	housing ass' y	1
10	175-15-42412	油缸体	housing	1
11	04260-00952	钢珠	ball, steel	2
12	175-15-42971	阀套	collar	2
13	234-15-12790	螺塞	plug	2
14	175-15-42430	O 型圈	o-ring	1
15	175-15-42230	绞制孔螺栓	bolt, reamer	16
16	175-15-42240	锁片	lock	8
17	01582-11210	螺帽	nut	16
18	234-21-12180	螺帽	nut	1
19	175-15-42220	销	pin	1
20	234-21-12190	垫板	plate	1
21	234-21-12210	锁片	lock	1
22	01010-50814	螺栓	bolt	1
23	154-15-22742	活塞	piston	1
24	154-15-22821	密封环	ring, seal	1
25	175-15-42180	弹簧	spring	1
26	04070-00130	开口环	ring, snap	1
27	155-15-12371	齿轮	gear	1
28	04020-01228	定位销	pin, dowel	6

变速箱齿轮和轴 (3/3)

TRANSMISSION GEAR AND SHAFT

序 号 INDEXNO.	图 号 PART NO.	名 称 DESCRIPTION	数量 Q`TY
207-29	06000-06924	轴承 bearing	1
30	130-09-16780	卡环 ring, snap	1
31	155-15-12420	齿鼓 drum	1
32	04020-01228	定位销 pin, dowel	4
33	01010-51230	螺栓 bolt	12
34	01602-21236	弹簧垫圈 washer, spring	12
35	154-15-12715	摩擦片 disk	3
36	281-15-12720	齿片 plate	2
37	175-15-42890	波状弹簧 spring, wave	3

第 208 图 变速输出装置
FIG. 208 TRANSMISSION TRANSFER

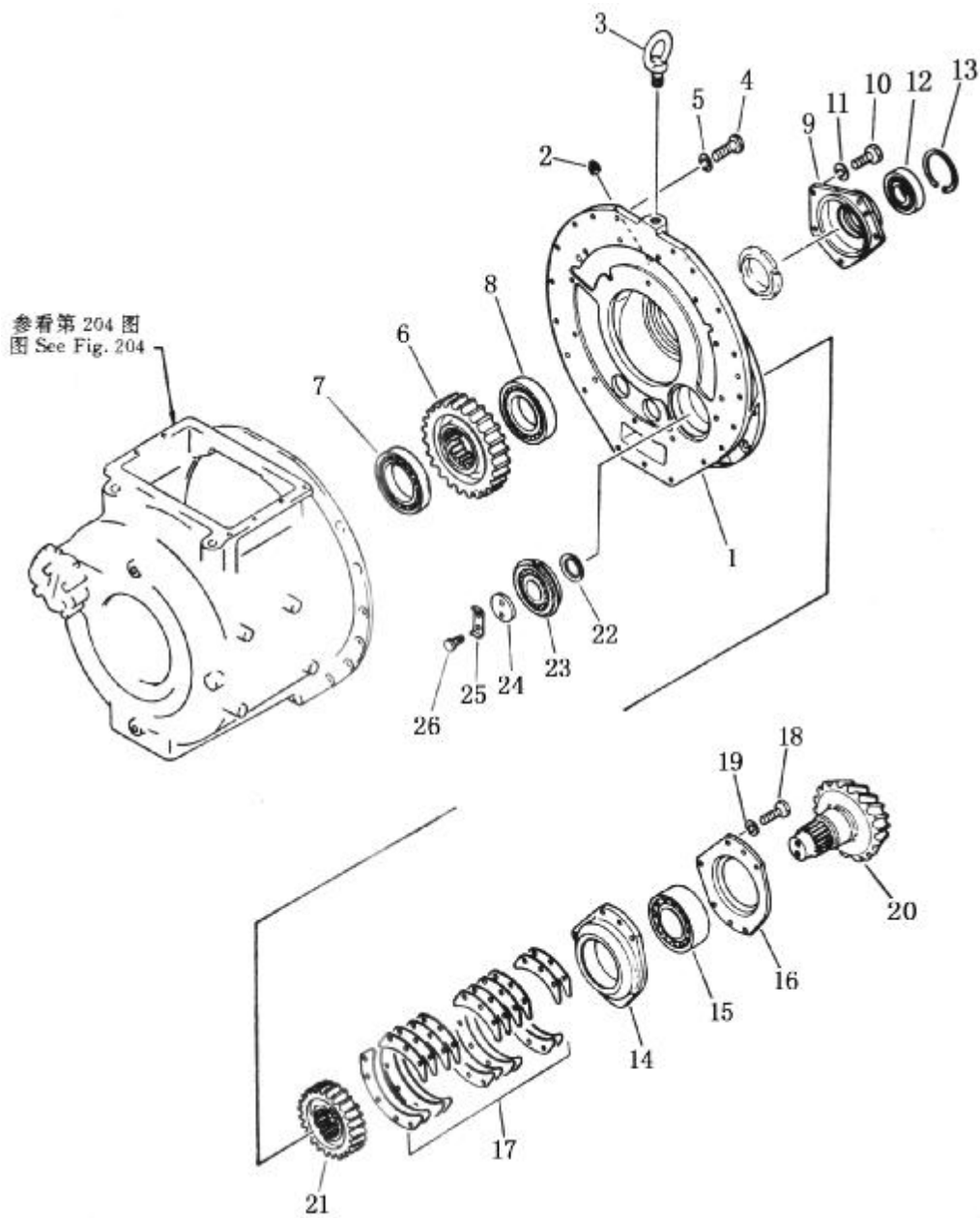

变速输出装置

TRANSMISSION TRANSFER

序 号 INDEXNO.	图 号 PART NO.	名 称 DESCRIPTION	数量 Q`TY
	(154-15-00333)	后壳总成 rear case ass' y	1
208-1	154-15-33110	后箱体 case	1
2	07042-20108	螺塞 plug	1
3	04530-02438	吊环螺栓 bolt, eye	1
4	01010-51240	螺栓 bolt	4
5	01602-21236	弹簧垫圈 washer, spring	4
6	154-15-33211	齿轮 gear	1
7	175-15-49340	轴承 bearing	1
8	175-15-43270	轴承 bearing	1
9	154-15-23151	轴承座 cage, bearing	1
10	01010-51230	螺栓 bolt	5
11	01602-21236	弹簧垫圈 washer, spring	5
12	06000-22210	轴承 bearing	1
13	04065-09030	开口环 ring, snap	1
14	154-15-33350	轴承套 cage, bearing	1
15	154-15-29120	轴承 bearing	1
16	154-15-23360	盖 cover	1
17	(154-15-00420)	填片总成 shim ass' y	1
18	01010-51250	螺栓 bolt	5
19	01602-21236	弹簧垫圈 washer, spring	5
20	154-15-33240	小齿轮轴 shaft, with pinion	1
21	154-15-33230	齿轮 gear	1
22	154-15-33340	衬垫 spacer	1
23	154-15-39110	轴承 bearing	1
24	154-15-33390	托板 holder	1
25	04081-06012	锁片 lock	1
26	01010-51230	螺栓 bolt	2

第 209 图 变速控制阀 (1/3)
FIG. 209 TRANSMISSION CONTROL VALVE

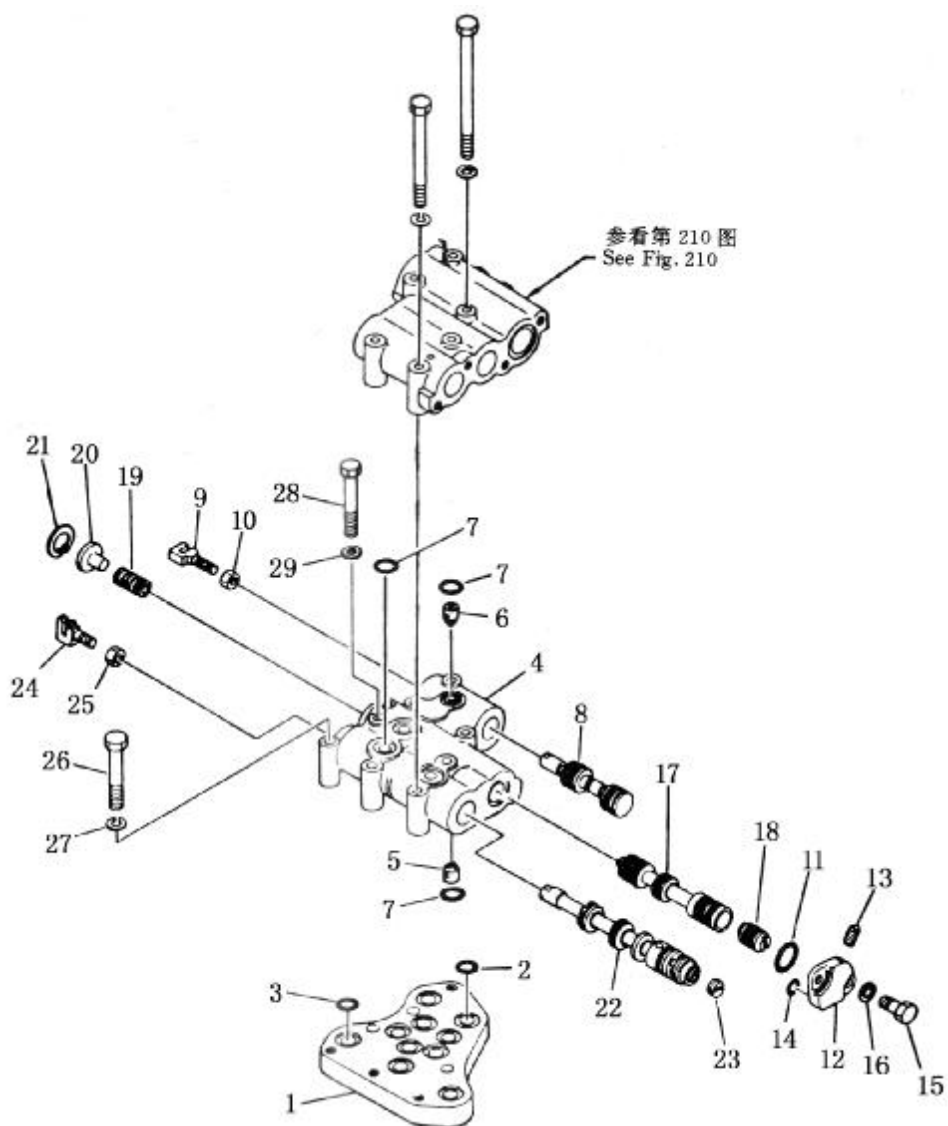

变速控制阀 (1/3)

TRANSMISSION CONTROL VALVE

序 号 INDEXNO.	图 号 PART NO.	名 称 DESCRIPTION	数量 Q`TY
	(154-15-35000)	变速阀总成 transmission valve ass'y	
209-1	175-15-45110	阀座 seat, valve	1
2	07000-63022	O 型圈 o-ring	1
3	07000-63025	O 型圈 o-ring	7
4	175-15-45212	阀体 body	3
5	175-15-45260	棘爪掣子 detent	1
	195-15-15680	弹簧 spring	1
	04260-00952	钢珠 ball	1
6	195-15-15671	棘爪掣子 detent	1
	195-15-15680	弹簧 spring	1
	04260-00952	钢珠 ball	1
7	07000-63022	O 型圈 o-ring	1
8	175-15-45220	卷轴 spool	5
9	09363-01053	轭 yoke	1
10	01580-11008	螺帽 nut	1
11	07000-63062	O 型圈 o-ring	1
12	175-15-45471	盖 cover	1
13	07042-00108	螺塞 plug	1
14	07000-62116	O 型圈 o-ring	1
15	01010-51025	螺栓 bolt	1
16	01602-21030	垫圈 washer	2
17	175-15-45420	卷轴 spool	2
18	175-15-35430	活塞 piston	1
19	195-15-15440	弹簧 spring	1
20	175-15-45450	挡板 retainer	1
21	04065-03515	开口环 ring, snap	1
22	175-15-45231	卷轴 spool	1
23	144-15-25210	螺塞 plug	1
24	09363-01053	轭 yoke	1
25	01580-11008	螺帽 nut	1
26	01010-51075	螺栓 bolt	1
27	01602-21030	垫圈 washer	1
28	175-15-45160	螺栓 bolt	1
29	01602-21030	垫圈 washer	1

第 210 图 变速控制阀 (2/3)
FIG. 210 TRANSMISSION CONTROL VALVE

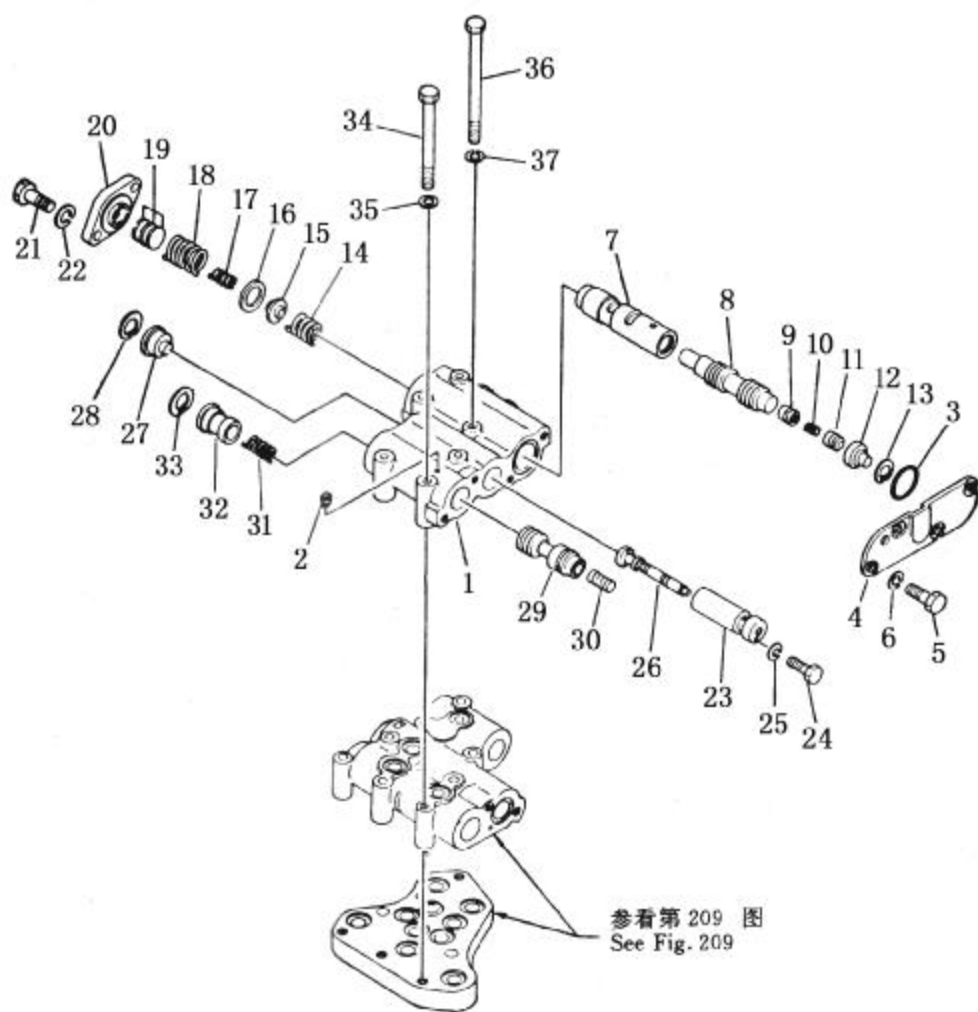

变速控制阀 (2/3)

TRANSMISSION CONTROL VALVE

序号 INDEXNO.	图号 PART NO.	名称 DESCRIPTION	数量 Q`TY
210-1	155-15-15410	阀体 body, valve	1
2	07042-00108	螺塞 plug	1
3	07000-63040	O型圈 o-ring	1
4	155-15-15850	盖 cover	1
5	01010-51025	螺栓 bolt	4
6	01602-21030	弹簧垫圈 washer, spring	4
7	145-14-43381	阀 valve	1
8	145-14-43331	阀 valve	1
9	175-15-15540	阀 valve	1
10	180-14-25560	弹簧 spring	1
11	175-15-15550	阀 valve	1
12	145-14-23180	锁挡 stopper	1
13	130-09-15170	开口环 ring, snap	1
14	154-15-36120	弹簧 spring	1
15	145-14-43340	垫座 seat	1
16	145-14-33450	垫圈 washer	1
17	154-15-36110	弹簧 spring	1
18	145-14-33351	弹簧 spring	1
19	145-14-43370	填片 shim	3
20	144-15-25330	盖 cover	1
21	01010-51025	螺栓 bolt	2
22	01602-21030	弹簧垫圈 washer, spring	2
23	155-15-15351	套筒 sleeve	1
24	155-15-15370	螺栓 bolt	1
25	01602-20619	弹簧垫圈 washer, spring	1
26	154-15-35320	阀 valve	1
27	155-15-15360	锁挡 stopper	1
28	04065-03515	开口环 ring, snap	1
29	175-15-45380	卷轴 spool	1
30	145-14-23720	活塞 piston	1
31	234-15-15230	弹簧 spring	1
32	175-15-45390	制动器 retainer	1

变速控制阀 (2/3)

TRANSMISSION CONTROL VALVE

序号 INDEXNO.	图号 PART NO.	名称 DESCRIPTION	数量 QTY
210-33	04065-03515	开口环 ring, snap	1
34	175-15-45170	螺栓 bolt	3
35	01602-21030	弹簧垫圈 washer, spring	3
36	175-15-45180	螺栓 bolt	3
37	01602-21030	弹簧垫圈 washer, spring	3

第 211 图 变速控制阀 (3/3)
 FIG. 211 TRANSMISSION CONTROL VALVE

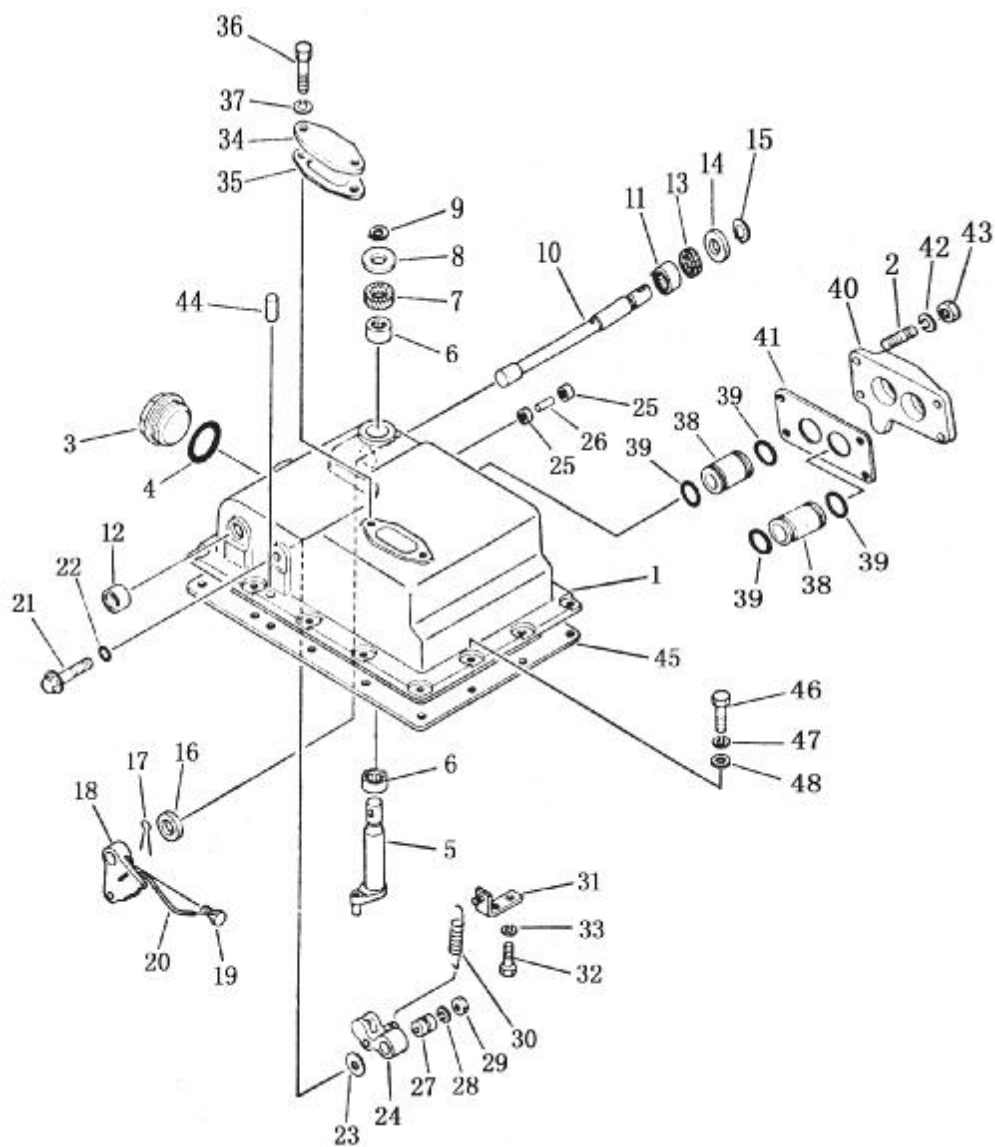

变速控制阀 (3/3)

TRANSMISSION CONTROL VALVE

序 号 INDEXNO.	图 号 PART NO.	名 称 DESCRIPTION	数量 Q`TY
211-1	175-15-45510	盖 cover	1
2	01124-51025	双头螺栓 stud bolt	4
3	07040-15223	螺塞 plug	1
4	07002-05234	O型圈 o-ring	1
5	175-15-45560	杠杆 lever	1
6	06120-02016	轴承 bearing	2
7	144-15-29110	油封 seal, oil	1
8	175-15-45570	垫圈 washer	1
9	175-15-45580	开口环 ring, snap	1
10	175-15-45610	轴 shaft	1
11	06120-02016	轴承 bearing	1
12	06121-02016	轴承 bearing	1
13	144-15-29110	油封 seal, oil	1
14	175-15-45570	垫圈 washer	1
15	175-15-45580	开口环 ring, snap	1
16	175-15-45620	锁挡 stopper	1
17	04050-03040	开口环 ring, snap	1
18	175-15-45630	杠杆 lever	1
19	125-15-11530	螺栓 bolt	1
20	04095-01010	锁紧钢丝 wire, lock	1
21	175-15-45650	螺栓 bolt	1
22	07002-01223	O型圈 o-ring	1
23	175-15-45660	垫圈 washer	2
24	175-15-45690	杠杆 lever	1
25	144-15-29120	轴承 bearing	2
26	144-15-25690	滚柱 roller	1
27	175-15-45670	套筒 sleeve	1
28	01602-21030	垫圈 washer	1
29	01580-11008	螺帽 nut	1
30	175-15-45710	弹簧 spring	1
31	175-15-45780	托架 bracket	1
32	01010-51020	螺栓 bolt	2
33	01602-21030	垫圈 washer	2

变速控制阀 (3/3)

TRANSMISSION CONTROL VALVE

序 号 INDEXNO.	图 号 PART NO.	名 称 DESCRIPTION	数量 Q`TY
211-34	175-15-45750	垫板 plate	1
35	175-15-45760	填密垫 gasket	1
36	01010-51020	螺栓 bolt	2
37	01602-21030	垫圈 washer	2
38	175-15-45550	套筒 sleeve	2
39	07000-63028	O型圈 o-ring	4
40	175-15-45530	盖 cover	1
41	175-15-45540	填密垫 gasket	1
42	01602-21030	垫圈 washer	4
43	01580-11008	螺帽 nut	4
44	04020-00820	定位销 pin, dowel	2
45	175-15-45520	填密垫 gasket	1
46	01010-51025	螺栓 bolt	14
47	01602-21030	垫圈 washer	14
48	01640-21016	垫圈 washer	14

第 212 图 变速控制杆
FIG. 212 TRANSMISSION CONTROL LEVER

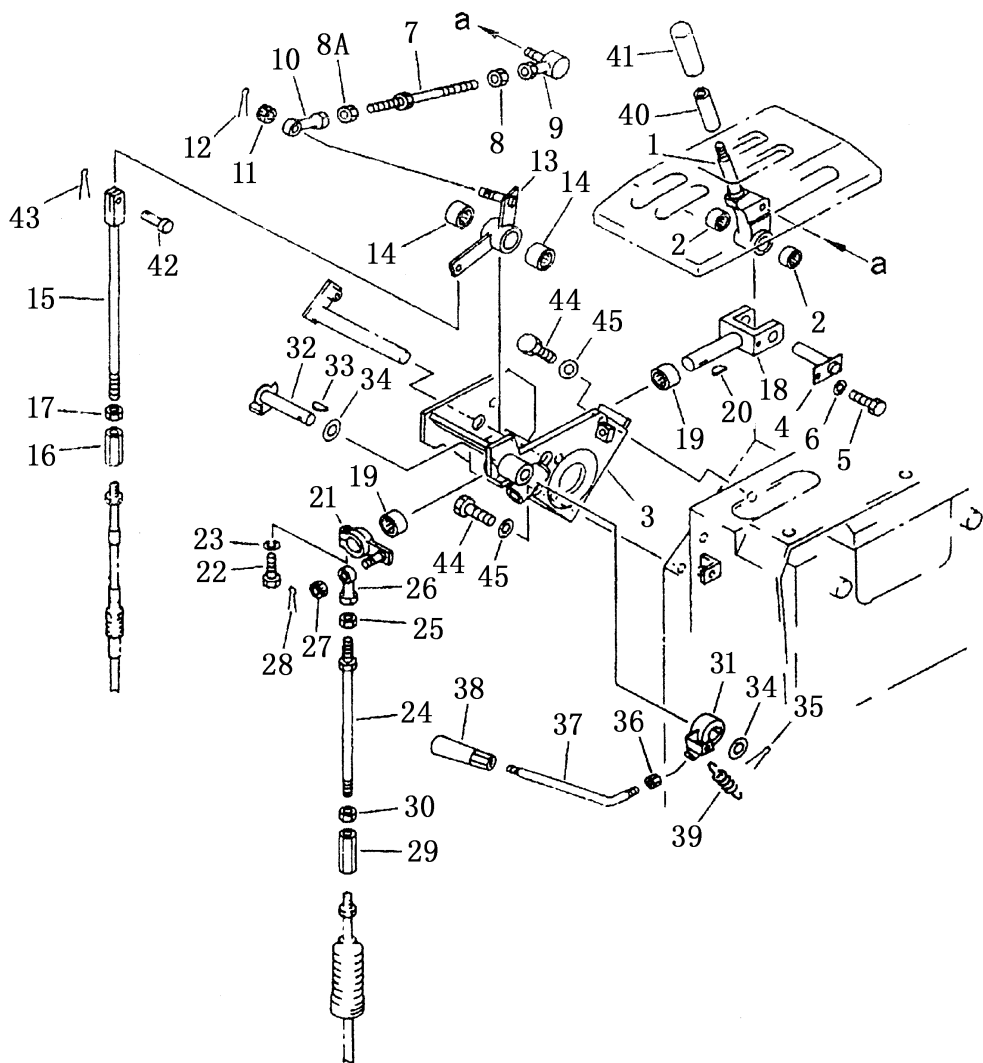

变速控制杆

TRANSMISSION CONTROL LEVER

序号 INDEXNO.	件号 Part No.	名称 Description	数量 Q' ty
212-1	195-43-43150	摇臂 lever	1
2	195-61-34120	轴承 bearing	2
3	154-43-43130	支架 bracket	1
4	195-43-43170	销 pin	1
5	01010-50616	螺栓 bolt	1
6	01643-30623	垫圈 washer	1
7	113-43-11530	螺杆 rod	1
8	01580-10806	螺母 nut	1
8A	01508-40805	螺母 nut	1
9	04256-00816	球接头 joint ball	1
10	04250-90847	关节轴承 end bearing	1
11	01590-10809	螺母 nut	1
12	04050-12015	开口销 pin cotter	1
13	154-43-43150	摇臂 lever	1
14	195-43-43190	轴承 bearing	2
15	195-43-41580	杆 rod	1
16	144-43-51130	接头 joint	1
17	01508-20805	螺母 nut	1
18	154-43-43210	叉口板 yoke	1
19	195-43-43190	轴承 bearing	2
20	04010-00519	半圆键 key	1
21	154-43-43220	杆 lever	1
22	01010-50830	螺栓 bolt	1
23	01602-20825	弹簧垫圈 washer spring	1
24	04248-31028	杆 rod	1
25	01582-11008	螺栓 bolt	1
26	04250-81056	关节轴承 end bearing	1
27	01593-11008	螺母 nut	1
28	04050-12018	开口销 pin cotter	1
29	178-43-12180	调整螺丝 buckle turn	1
30	01508-21006	螺母 nut	1
31	195-43-43241	摇臂 lever	1
32	154-43-43260	销 pin	1
33	04010-00519	半圆键 key	1
34	01640-21626	垫圈 washer	2
35	04050-14025	开口销 pin cotter	1

变速控制杆

TRANSMISSION CONTROL LEVER

序 号 INDEXNO.	件 号 Part No.	名 称 Description	数量 Q' ty
212-36	195-43-43370	螺母 nut	1
37	195-43-43360	杆 lever	1
38	09305-00800	手柄 knob	1
39	195-43-43260	弹簧 spring	1
40	09361-01460	衬套 bushing	1
41	09304-01240	手柄 knob	1
42	04205-10822	销轴 pin	1
43	04050-12015	开口销 pin cotter	1
44	01010-51225	螺栓 bolt	4
45	01643-31232	垫圈 washer	4

第 213 图

变速控制连杆 (1/3)

FIG. 213

TRANSMISSION CONTROL LINKAGE

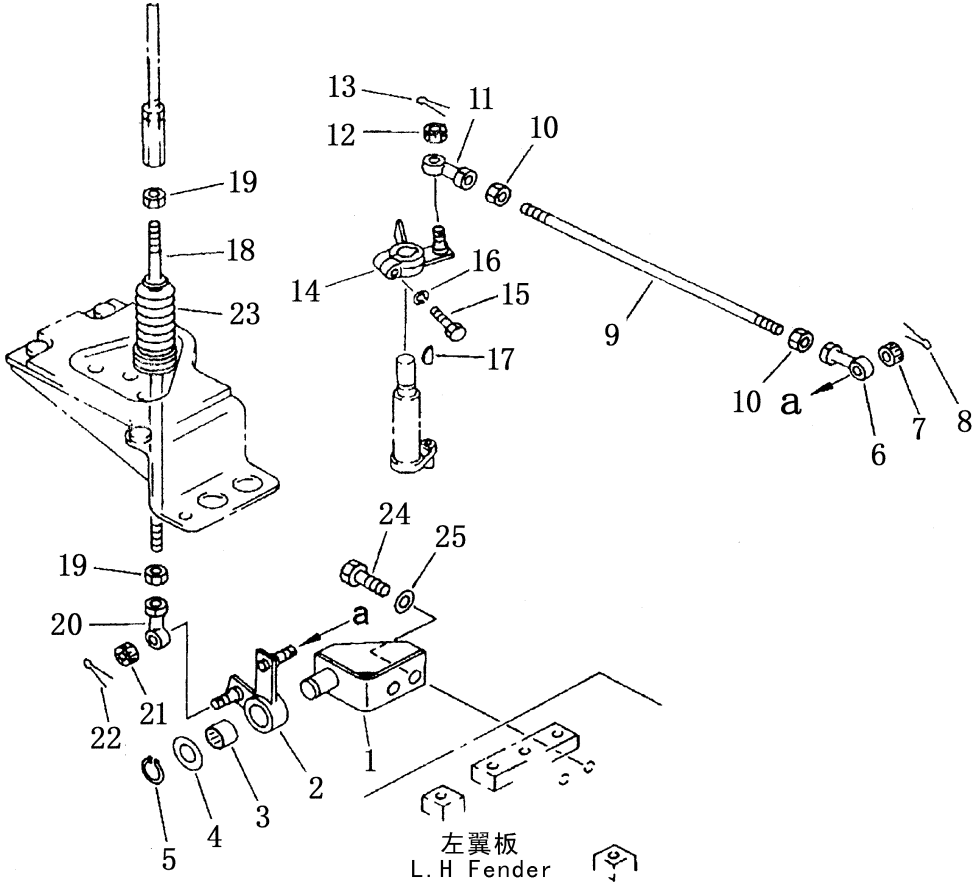

变速控制连杆 (1/3)

TRANSMISSION CONTROL LINKAGE

序号 INDEXNO.	件号 Part No.	名称 Description	数量 Q' ty
213-1	154-43-43230	支座 bracket	1
2	154-43-43240	摇臂 lever	1
3	195-43-43190	轴承 bearing	1
4	01640-22032	垫圈 washer	1
5	04064-02012	挡圈 ring snap	1
6	04250-81056	关节轴承 end bearing	1
7	01593-11008	螺母 nut	1
8	04050-12018	开口销 pin cotter	1
9	23Y-25B-00002	杆 rod	1
10	01582-11008	螺母 nut	2
11	04250-81056	关节轴承 end bearing	1
12	01593-11008	螺母 nut	1
13	04050-12018	开口销 pin cotter	1
14	23Y-25B-02000	摇臂 lever	1
15	01010-50830	螺栓 bolt	1
16	01602-20825	垫圈 washer	1
17	04010-00516	半圆键 key	1
18	04245-41036	杆 rod	1
19	01582-11008	螺母 nut	2
20	04250-81056	关节轴承 end bearing	1
21	01593-11008	螺母 nut	1
22	04050-12018	开口销 pin cotter	1
23	195-43-42280	波纹管 bellows	1
24	01010-51225	螺栓 bolt	2
25	01643-31232	垫圈 washer	2

第 214 图 变速控制连杆 (2/3)
FIG. 214 TRANSMISSION CONTROL LINKAGE

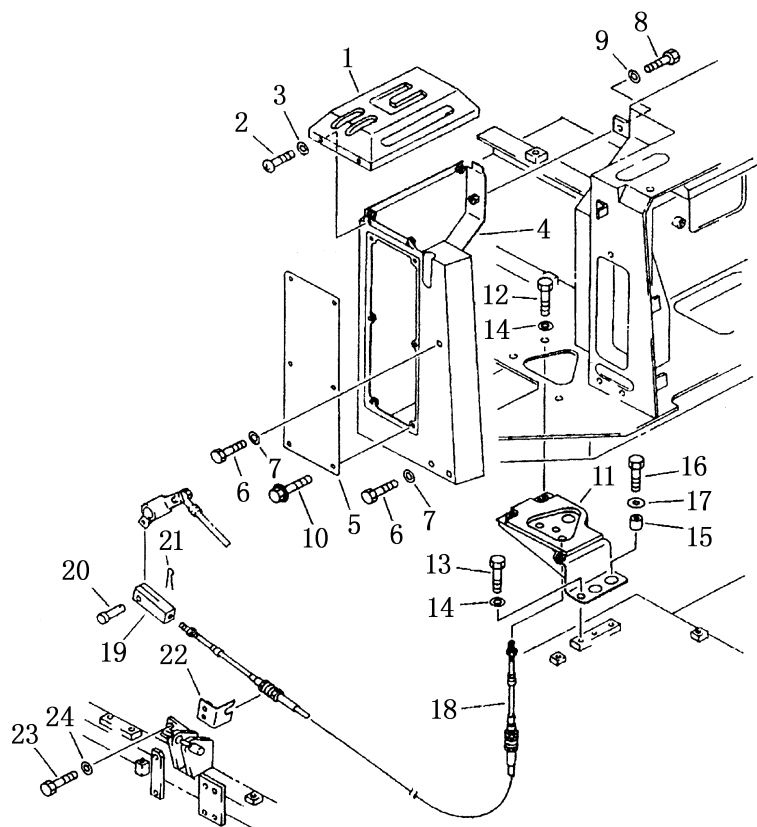

变速控制连杆（2/3）

TRANSMISSION CONTROL LINKAGE

序 号 INDEXNO.	件 号 Part No.	名 称 Description	数量 Q' ty
214-1	154-43-43110	导座 guide	1
2	01220-40816	螺钉 screw	4
3	01643-30823	垫圈 washer	4
4	154-43-43310	盖板 cover	1
5	154-43-43270	盖板 cover	1
6	01010-51290	螺栓 bolt	3
7	01643-31232	垫圈 washer	3
8	01010-51225	螺栓 bolt	2
9	01643-31232	垫圈 washer	2
10	195-54-26220	螺栓 bolt	6
11	154-43-43140	支座 bracket	1
12	01010-51230	螺栓 bolt	3
13	01010-51220	螺栓 bolt	1
14	01643-31232	垫圈 washer	4
15	175-61-14490	隔套 spacer	2
16	01010-51240	螺栓 bolt	2
17	175-54-34170	垫圈 washer	2
18	154-43-43160	软轴 cable	1
19	04211-20844	叉口板 yoke	1
20	04205-10822	销轴 pin	1
21	04050-12015	开口销 pin cotter	1
22	154-43-41270	板 plate	1
23	01010-51030	螺栓 bolt	2
24	01643-31032	垫圈 washer	2

第 215 图 变速控制连杆 (3/3)
FIG. 215 TRANSMISSION CONTROL LINKAGE

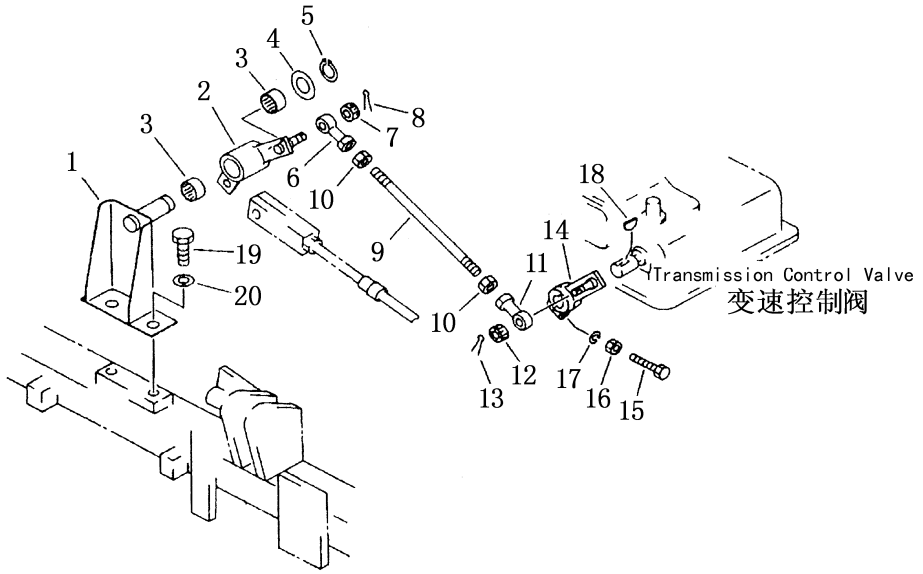

变速控制连杆 (3/3)

TRANSMISSION CONTROL LINKAGE

序 号 INDEXNO.	件 号 Part No.	名 称 Description	数量 Q' ty
215-1	154-43-43170	支架 bracket	1
2	154-43-43180	摇臂 lever	1
3	195-43-43190	轴承 bearing	2
4	01640-22032	垫圈 washer	1
5	04064-02012	挡圈 ring snap	1
6	04250-81056	关节轴承 end rod	1
7	01593-11008	螺母 nut	1
8	04050-12018	开口销 pin cotter	1
9	23Y-25B-00001	杆 rod	1
10	01582-11008	螺母 nut	2
11	04250-81056	关节轴承 end rod	1
12	01593-11008	螺母 nut	1
13	04050-12018	开口销 pin cotter	1
14	23Y-25B-01000	摇臂 lever	1
15	01016-50850	螺栓 bolt	1
16	01580-10806	螺母 nut	1
17	01602-20825	弹簧垫圈 washer spring	1
18	04010-00516	半圆键 key	1
19	01010-51225	螺栓 bolt	2
20	01643-31232	垫圈 washer	2

第 216 图 变 速 泵
FIG. 216 TRANSMISSION PUMP

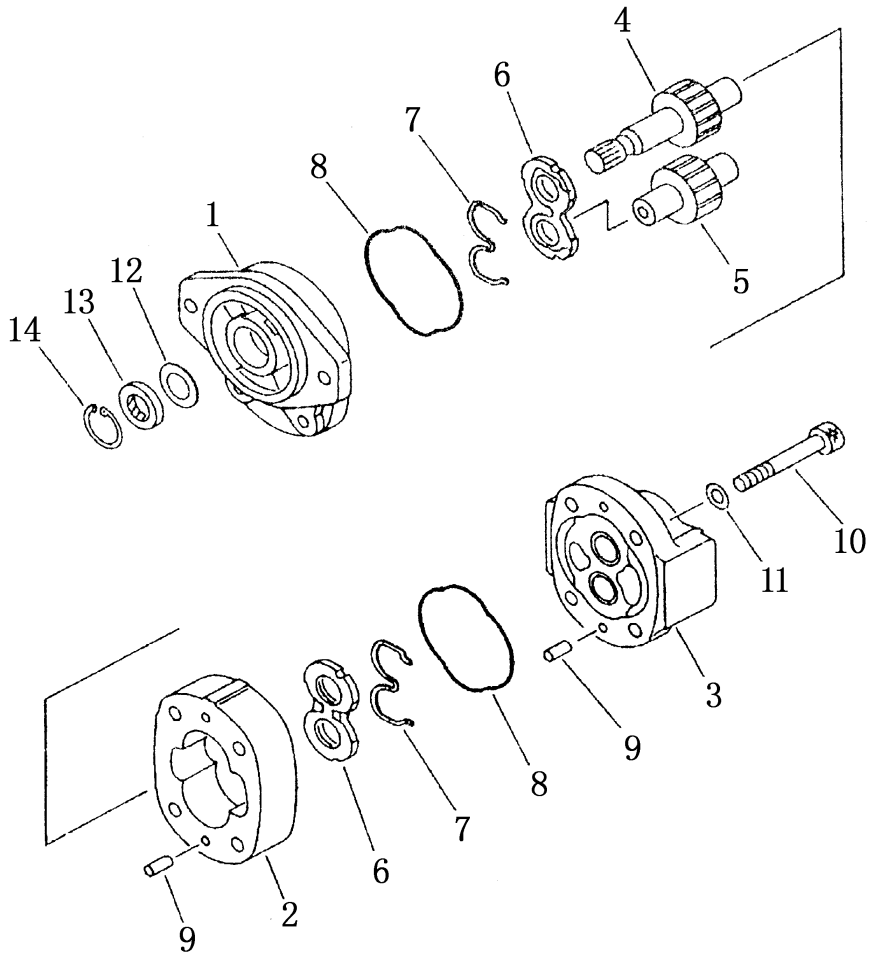

变 速 泵
TRANSMISSION PUMP

序 号 INDEXNO.	件 号 Part No.	名 称 Description	数量 Q' ty
	705-21-32051	变速泵 pump, ass'y	1
216-1	705-17-02011	前盖 bracket	1
2	705-17-32012	泵体 case gear	1
3	705-17-02141	后盖 cover	1
4	705-17-32412	齿轮 gear drive	1
5	705-17-32512	齿轮 gear drive	1
6	705-17-02612	侧板 plate side	2
7	705-18-02670	密封 ring seal	2
8	705-17-02360	O形圈 O-ring	2
9	04020-01024	销 pin dowel	4
10	705-17-02760	螺栓 bolt	4
11	01643-51232	垫圈 washer	4
12	705-17-02870	垫 gasket	1
13	705-17-02830	油封 seal oil	1
14	04065-04018	卡环 ring snap	1

第 217 图 液力变矩器管路 (1/2)
 FIG.217 TORQUE CONVERTER PIPING

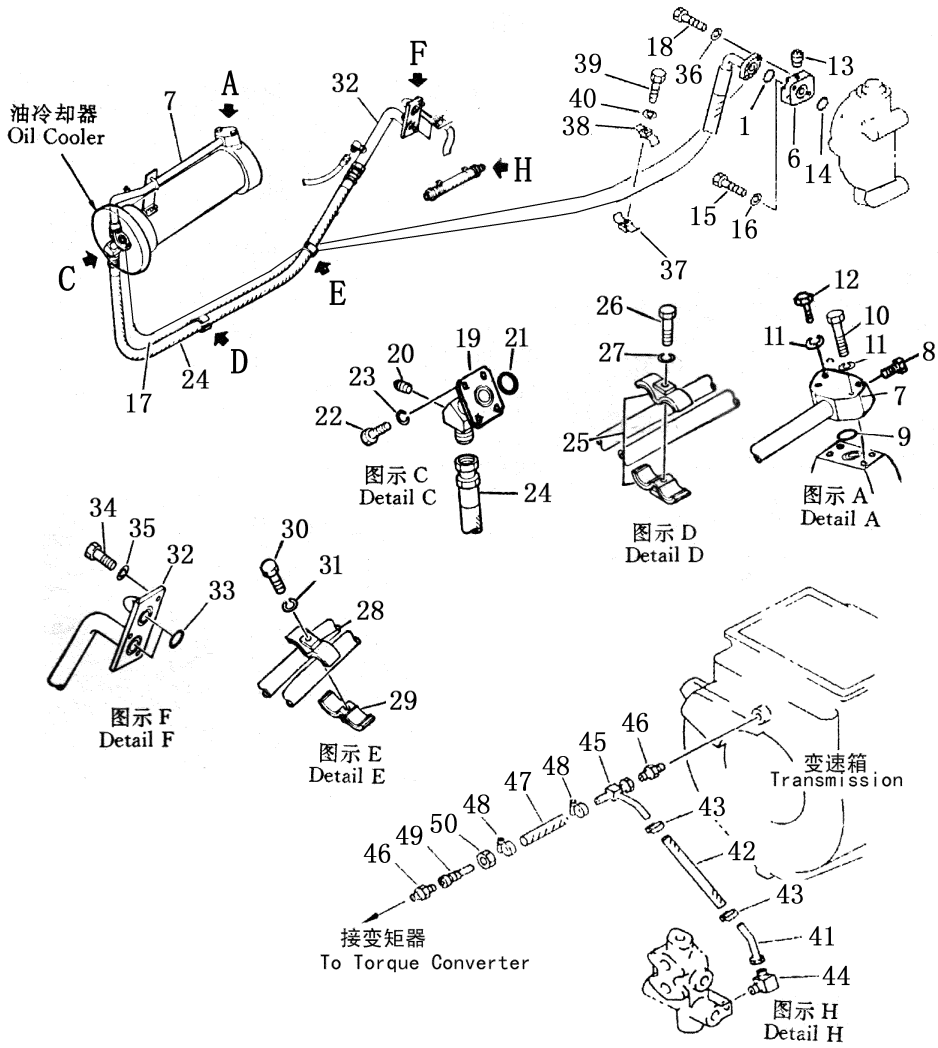

液力变矩器管路 (1/2)
TORQUE CONVERTER PIPING

序号 INDEX NO.	图号 PART NO.	名称 DESCRIPTION	数量 Q`TY
217-1	07000-03032	O型圈 O-ring	1
6	154-49-51420	法兰 flange	1
7	23Y-74B-08000	管 tube	1
8	07042-30108	螺塞 plug	1
9	07000-02060	O型圈 O-ring	1
10	02010-70838	螺栓 bolt	2
11	01602-21338	弹簧垫圈 washer, spring	4
12	02010-70870	螺栓 bolt	2
13	07042-30108	螺塞 plug	1
14	07000-33045	O型圈 O-ring	1
15	01252-41030	螺栓 bolt	2
16	01643-31032	弹簧垫圈 washer, spring	2
17	17Y-74-30000	软管 hose	1
18	01010-51030	螺栓 bolt	2
19	23Y-74B-07000	管 tube	1
20	07042-30108	螺塞 plug	1
21	07000-02060	O型圈 O-ring	1
22	02010-70838	螺栓 bolt	4
23	01602-21338	弹簧垫圈 washer, spring	2
24	07102-21013	软管 hose	1
25	154-49-22290	夹子 clamp	2
26	01010-51270	螺栓 bolt	1
27	01602-21236	弹簧垫圈 washer, spring	1
28	195-78-22330	夹箍 clamp	1
29	195-78-22320	夹箍 clamp	1
30	01010-51260	螺栓 bolt	1
31	01602-21236	弹簧垫圈 washer, spring	1
32	23Y-74B-05000	管 tube	1
33	07000-03030	O型圈 O-ring	2
34	01010-51030	螺栓 bolt	3
35	01602-21030	垫圈 washer	3
36	01643-31032	垫圈 washer	2

液力变矩器管路 (1/2)
TORQUE CONVERTER PIPING

序 号 INDEX NO.	图 号 PART NO.	名 称 DESCRIPTION	数量 Q`TY
217-37	195-78-22320	弓形夹 clamp	1
38	195-78-22330	夹子 clamp	1
39	01010-51260	螺栓 bolt	1
40	01643-31232	垫圈 washer	1
41	154-49-51390	管 tube	1
42	07260-20922	软管 hose	1
43	07281-00197	喉箍 clamp	2
44	22W-44-14580	弯管接头 elbow	1
45	154-49-51410	管 tube	1
46	07213-51521	接头 joint	2
47	07260-21413	软管 hose	1
48	07281-00259	喉箍 clamp	2
49	154-19-22213	管 tube	1
50	07201-61527	螺母 nut	1

第 218 图 液力变矩器管路 (2/2)
 FIG. 218 TORQUE CONVERTER PIPING

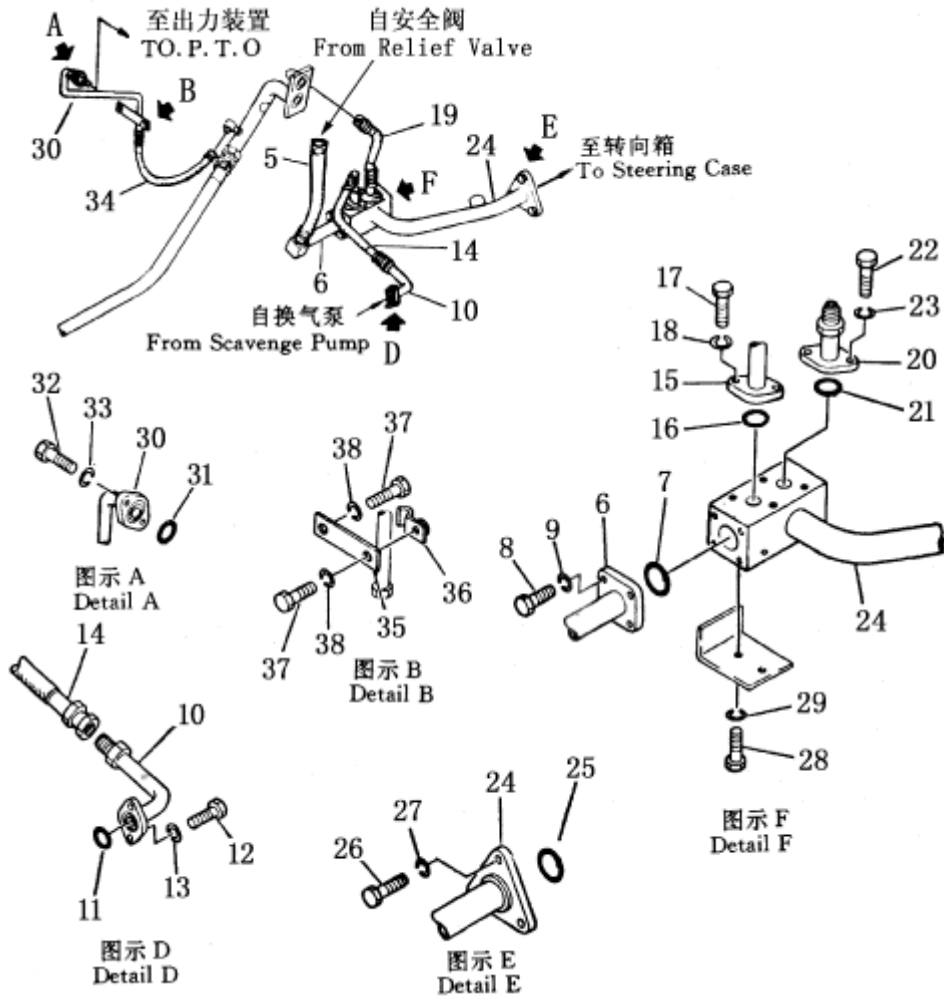

液力变矩器管路 (2/2)
TORQUE CONVERTER PIPING

序 号 INDEX NO.	图 号 PART NO.	名 称 DESCRIPTION	数量 Q`TY
218-5	07102-21010	软管 hose	1
6	23Y-74B-09000	管 tube	1
7	07000-03045	O 型圈 O-ring	1
8	01010-51035	螺栓 bolt	4
9	01602-21030	弹簧垫圈 washer, spring	4
10	154-49-21450	管 tube	1
11	07000-03025	O 型圈 O-ring	1
12	01010-51030	螺栓 bolt	2
13	01602-21030	弹簧垫圈 washer, spring	2
14	07120-20403	软管 hose	1
15	154-49-23192	管 tube	1
16	07000-03028	O 型圈 O-ring	1
17	01010-51035	螺栓 bolt	2
18	01602-21030	弹簧垫圈 washer, spring	2
19	07102-20403	软管 hose	1
20	154-49-23210	管 tube	1
21	07000-03028	O 型圈 O-ring	1
22	01010-51035	螺栓 bolt	2
23	01602-21030	弹簧垫圈 washer, spring	2
24	154-49-21383	管 tube	1
25	07000-02065	O 型圈 O-ring	1
26	01010-51230	螺栓 bolt	3
27	01602-21236	弹簧垫圈 washer, spring	3
28	01010-51225	螺栓 bolt	2
29	01602-21236	弹簧垫圈 washer, spring	2
30	154-49-23220	管 tube	1
31	07000-03025	O 型圈 O-ring	1
32	01010-51030	螺栓 bolt	2
33	01602-21030	弹簧垫圈 washer, spring	2
34	07102-20303	软管 hose	1
35	154-49-23230	垫板 plate	1
36	154-49-25331	卡箍 clamp	1
37	01010-51025	螺栓 bolt	2
38	01602-21030	弹簧垫圈 washer, spring	2

第 219 图

变 速 管 路

FIG. 219 TORQFLOW TRANSMISSION PIPING

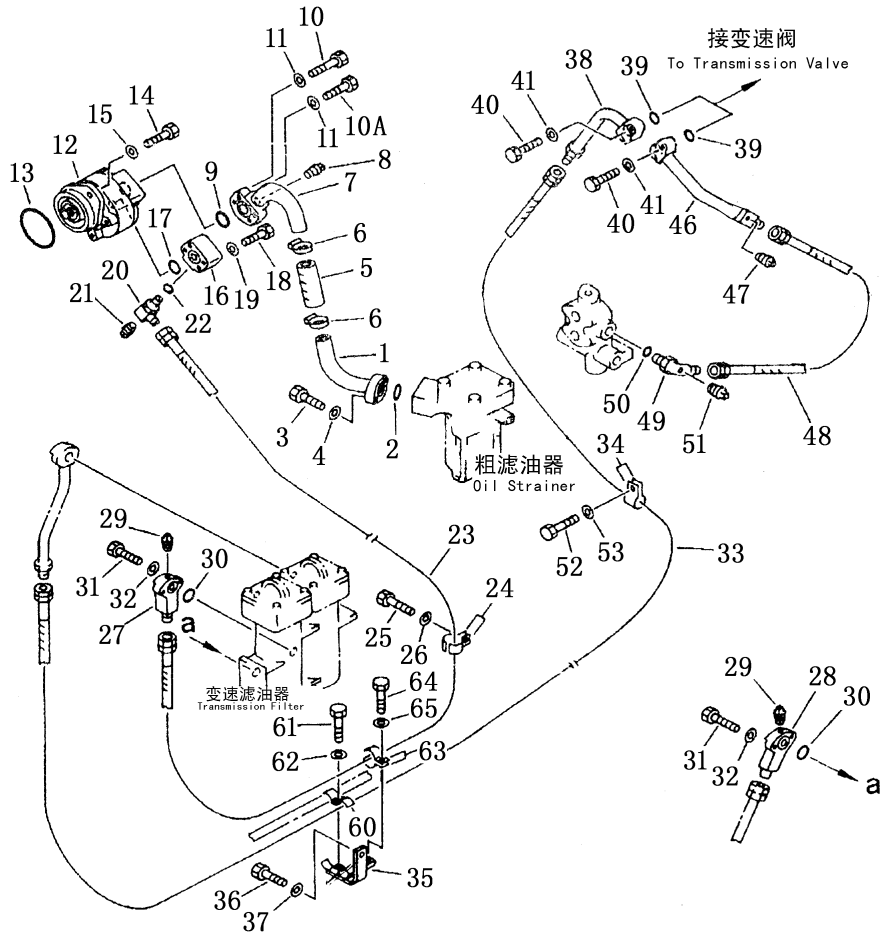

变 速 管 路
TORQFLOW TRANSMISSION PIPING

序 号 INDEXNO.	件 号 Part No.	名 称 Description	数量 Q' ty
219-1	154-49-51163	管 tube	1
2	07000-03042	O形圈 O-ring	1
3	01010-51240	螺栓 bolt	2
4	01643-31232	垫圈 washer	2
5	07260-03213	软管 hose	1
6	07281-00549	喉箍 clamp	2
7	154-49-51173	管 tube	1
8	07042-30108	螺塞 plug	1
9	07000-03035	O形圈 O-ring	1
10	01010-51060	螺栓 bolt	2
10A	01010-51055	螺栓 bolt	2
11	01643-31032	垫圈 washer	4
12	705-21-32051	变速泵 pump ass'y	1
13	07000-02105	O形圈 O-ring	1
14	01010-51235	螺栓 bolt	2
15	01643-31232	垫圈 washer	2
16	154-49-11362	弯管接头 elbow	1
17	07000-03030	O形圈 O-ring	1
18	01010-50860	螺栓 bolt	4
19	01643-30823	垫圈 washer	4
20	07235-50628	接头 elbow	1
21	07042-30108	螺塞 plug	1
22	07002-02434	O形圈 O-ring	1
23	07108-20616	软管 hose	1
24	154-49-51970	管夹 clamp	2
25	01010-51225	螺栓 bolt	1
26	01643-31232	垫圈 washer	1
27	154-49-51241	管接头 elbow	1
28	154-49-51751	管接头 elbow	1
29	07042-30108	螺塞 plug	2
30	07000-03035	O形圈 O-ring	2
31	01010-51045	螺栓 bolt	4
32	01643-31032	垫圈 washer	4
33	07108-20622	软管 hose	1

变 速 管 路
TORQFLOW TRANSMISSION PIPING

序 号 INDEXNO.	件 号 Part No.	名 称 Description	数量 Q'ty
219-34	154-49-51970	管夹 clamp	2
35	154-49-52110	支架 bracket	1
36	01010-51225	螺栓 bolt	1
37	01643-31232	垫圈 washer	1
38	154-49-21295	管 tube	1
39	07000-03028	O形圈 O-ring	2
40	01010-51055	螺栓 bolt	4
41	01643-31032	垫圈 washer	4
46	154-49-21314	管 tube	1
47	07042-30108	螺塞 plug	1
48	07103-20604	软管 hose	1
49	23Y-74B-02000	弯管接头 flange	1
50	07002-02434	O形圈 O-ring	1
51	07042-30108	螺塞 plug	1
52	01010-51020	螺栓 bolt	1
53	01643-31032	垫圈 washer	1
60	17Y-74-29000	弓形夹 clamp	1
61	01010-51040	螺栓 bolt	1
62	01643-31032	垫圈 washer	1
63	154-49-51970	管夹 clamp	2
64	01010-51230	螺栓 bolt	1
65	01643-31232	垫圈 washer	1

转向箱及终传动
STEERING SYSTEM AND FINAL DRIVE

转向箱及主机架
STEERING CASE AND MAIN FRAME

序号 NO.	图 号 PART NO.	名 称 DESCRIPTION	数量 Q' ty		
			SD22, SD22E SD22D	SD22S	
301-1	23Y-30B-01000	后桥箱及主 机架	case, steering and frame, main	1	
	158-30-01000	后桥箱及主 机架	case, steering and frame, main		1
2	07044-13620	放油塞	plug, magnetic	3	3
3	07002-03634	0 型密封圈	o-ring	3	3
4	07040-13618	螺塞	plug	2	2
5	07002-03634	0 型密封圈	o-ring	2	2
6	07000-05195	0 型密封圈	o-ring	1	1
7	175-21-32170	盖	cover	1	1
8	01010-52040	螺栓	bolt	6	6
9	01602-22060	弹簧垫圈	washer, spring	6	6
10	154-21-11830	接管	nipple	2	2
11	07030-00252	透气装置	breather	2	2
13	154-21-21510	垫片	gasket	1	1
14	04020-01842	圆柱销	pin, dowel	1	1
15	01120-31640	双头螺栓	stud	10	10
16	01582-11613	六角螺母	nut	10	10
17	01602-21648	弹簧垫圈	washer, spring	10	10
18	23Y-30B-02000	管	tube	1	1
19	07056-10045	滤网	strainer	1	1
20	07051-20000	箱帽	cap	1	1
21	154-21-11850	托架	bracket	1	1
22	01010-51245	螺栓	bolt	4	4
23	01602-21236	弹簧垫圈	washer, spring	4	4
24	01010-51230	螺栓	bolt	2	2
25	01602-21236	弹簧垫圈	washer, spring	2	2
26	01643-31232	加厚垫圈	washer	2	2
27	07260-24132	软管	hose	1	1
28	07281-00549	软管夹环	clamp, hose	2	2
29	154-21-11792	管	tube	1	1
30	07030-00252	透气装置	breather	1	1
31	154-21-11880	油尺	gauge	1	1
32	154-21-11860	垫片	gasket	1	1
33	01010-51240	螺栓	bolt	3	3
34	01602-21236	弹簧垫圈	washer, spring	3	3

第 302 图
FIG. 302

伞齿轮及轴
BEVEL GEAR AND SHAFT

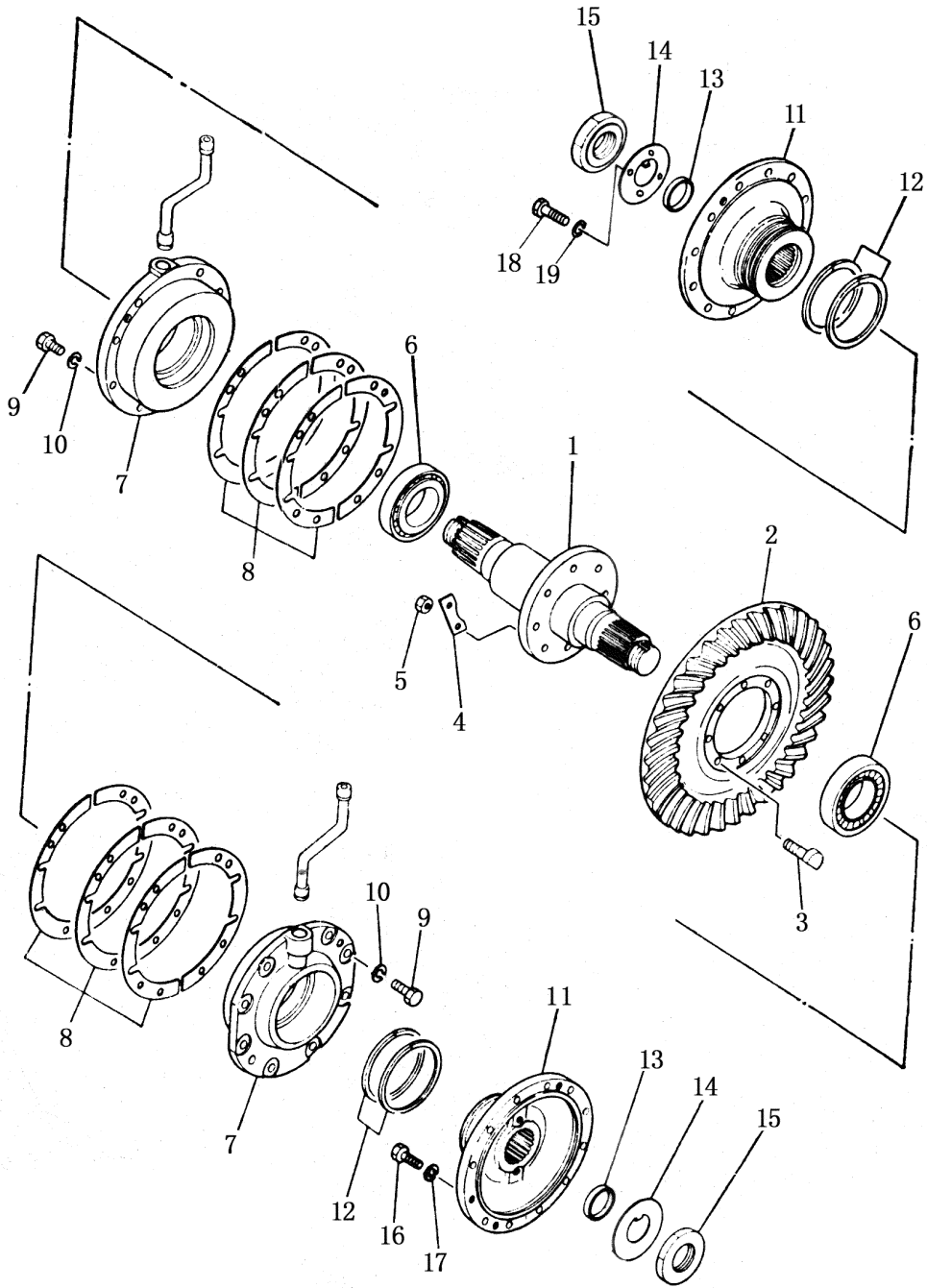

伞齿轮及轴

BEVEL GEAR AND SHAFT

序 号 INDEXNO.	图 号 PART NO.	名 称 DESCRIPTION	数量 Q`TY
302-1	154-21-12114	轴 shaft	1
2	154-21-22120	螺旋伞齿轮 gear, bevel	1
3	150-21-12130	螺栓 bolt	8
4	150-21-32140	锁紧垫圈 washer, lock	4
5	01582-11815	螺帽 nut	8
6	154-21-22161	锥形滚柱轴承 bearing, taper roller	2
7	154-21-12161	轴承座 cage, bearing	2
8	154-21-12350	垫片 shim	10
	154-21-12370	垫片 shim	10
	154-21-12390	垫片 shim	8
	154-21-12360	垫片 shim	10
	154-21-12380	垫片 shim	10
	154-21-12410	垫片 shim	8
9	01010-31445	螺栓 bolt	14
10	01602-01442	弹簧垫圈 washer, spring	14
11	198-21-11490	壳 hub	2
12	170-22-11130	密封环 ring, seal	4
13	154-21-22211	衬垫 packing	2
14	170-21-12240	锁片 lock	2
15	170-21-12241	螺帽 nut	2
16	01010-51645	螺栓 bolt	24
17	01602-21648	弹簧垫圈 washer, spring	24
18	01010-51025	螺栓 bolt	4
19	01643-31032	垫圈 washer	4

第 303 图 转向离合器
FIG. 303 STEERING CLUTCH

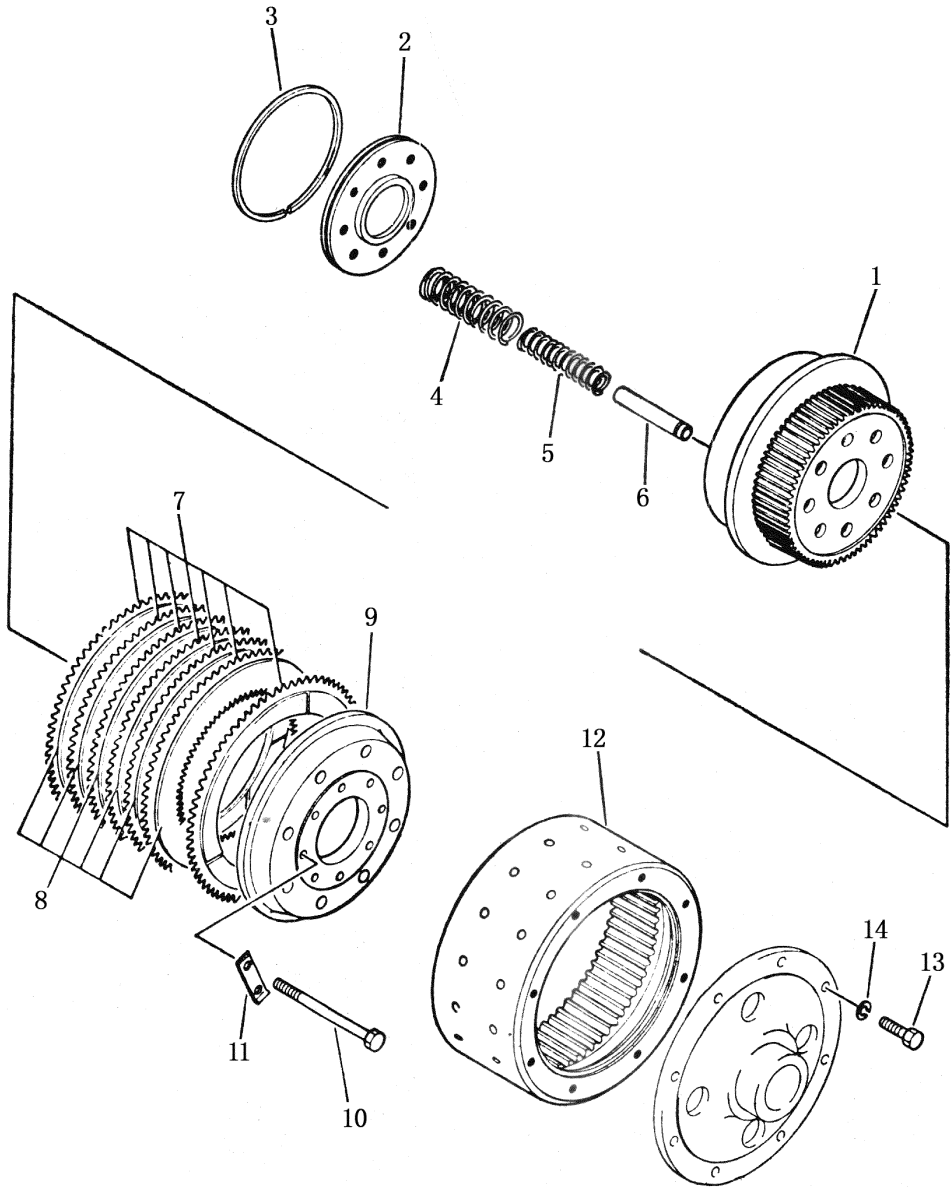

转向离合器
STEERING CLUTCH

序 号 INDEXNO.	图 号 PART NO.	名 称 DESCRIPTION	数量 Q`TY
	154-22-10001	转向离合器总成 steering clutch ass'y	2
303-1	154-22-11122	内鼓 drum, clutch inner	1
2	175-22-21141	活塞 piston	1
3	175-22-21190	密封环 ring, seal	1
4	175-22-21170	大弹簧 spring, large	8
5	175-22-21180	小弹簧 spring, small	8
6	154-22-11210	套管 sleeve	8
7	175-22-11230	摩擦片 disk	7
8	175-22-21160	内齿片 plate	6
9	175-22-21131	压盘 plate	1
10	154-22-12111	螺栓 bolt	8
11	175-22-21250	锁紧垫片 washer, lock	4
12	154-22-11111	外鼓 drum, clutch outer	1
13	01010-51850	螺栓 bolt	8
14	01602-21854	弹簧垫圈 washer, spring	8

第 304 图 制动带及联动装置
FIG. 304 BRAKE BAND AND LINKAGE

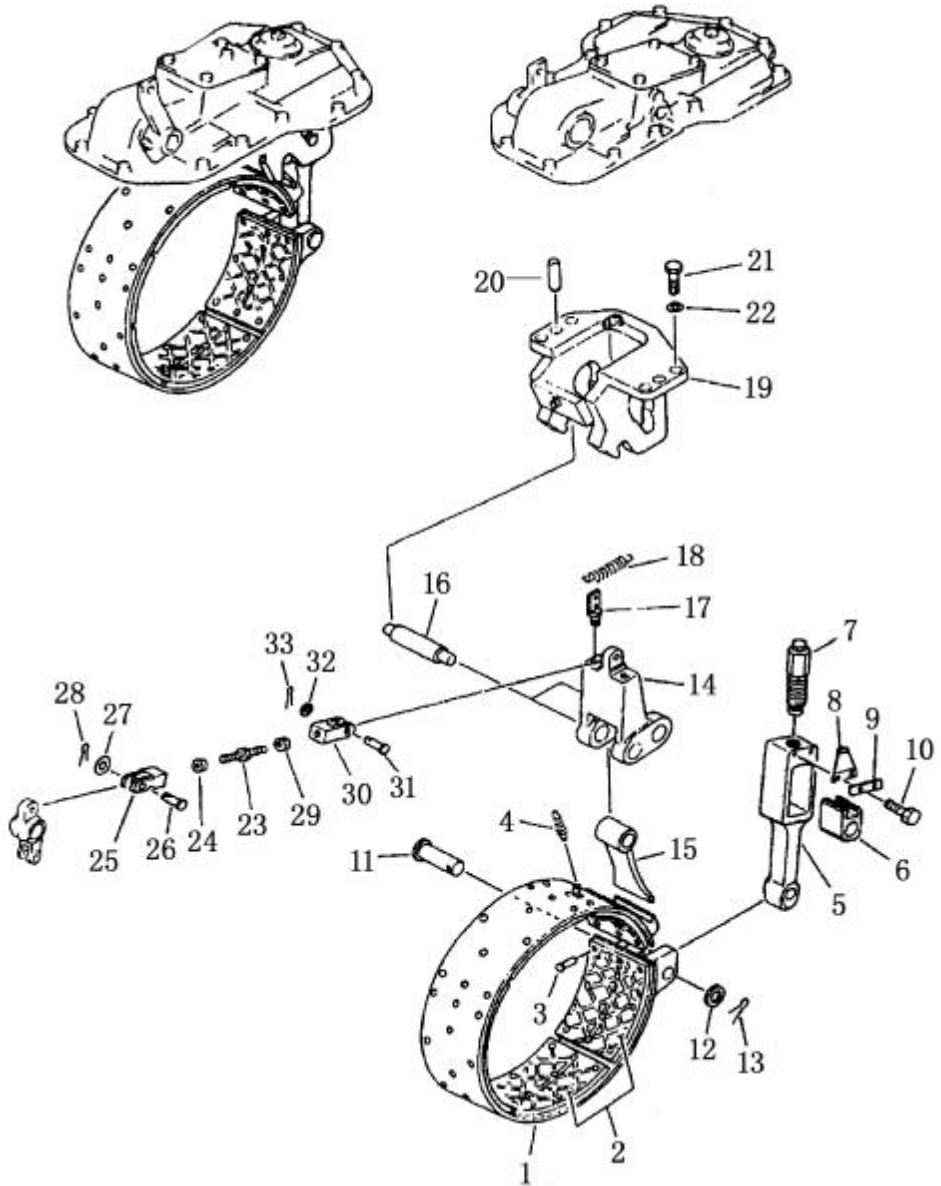

制动带及联动装置

BRAKE BAND AND LINKAGE

序号 INDEXNO.	件号 Part No.	名称 Description	数量 Q'ty
	23Y-17B-00000	转向制动总成, 本总成包括图 304 至 306 中的所有零件 Steering and brake ass'y, this assembly consists of all parts shown in Fig.304 to 306	
304-1	154-33-11111	制动带 band brake	1
2	154-33-13110	制动衬带 lining brake	6
3	04412-00512	铆钉 rivet	60
4	100-33-13120	弹簧 spring	2
5	154-33-11530	杆 rod	2
6	154-33-11540	块 block	2
7	154-33-11550	调整螺栓 bolt adjusting	2
8	154-33-11610	弹簧 spring	2
9	154-33-11620	锁板 plate lock	2
10	01010-51016	螺栓 bolt	4
11	154-33-11510	销 pin	2
12	154-33-11520	垫圈 washer	2
13	04050-04040	开口销 pin cotter	2
14	154-33-11570	杠杆 lever	2
15	154-33-11560	尾端 end	2
16	175-33-24260	锁轴 shaft	4
17	154-33-11650	垫座 seat	2
18	150-33-12171	弹簧 spring	2
19	154-33-11642	托架 (左) bracket L.H	1
19	154-33-11632	托架 (右) bracket R.H	1
20	154-33-11720	定位销 pin dowel	4
21	01010-51850	螺栓 bolt	8
22	01643-31845	垫圈 washer	8
23	155-33-11130	调整螺栓 bolt adjusting	2
24	01583-11610	螺帽 nut	2
25	154-33-22150	叉 yoke	2
26	04205-11645	销 pin	2
27	01641-21626	垫圈 washer	2
28	04050-14025	开口销 pin cotter	2
29	01508-21610	螺帽 nut	2
30	154-33-22360	叉 yoke	2
31	04205-11645	销 pin	2
32	01641-21626	垫圈 washer	2
33	04050-14025	开口销 pin cotter	2

第 305 图 制 动 盖
FIG. 305 BRAKEING CASE COVER

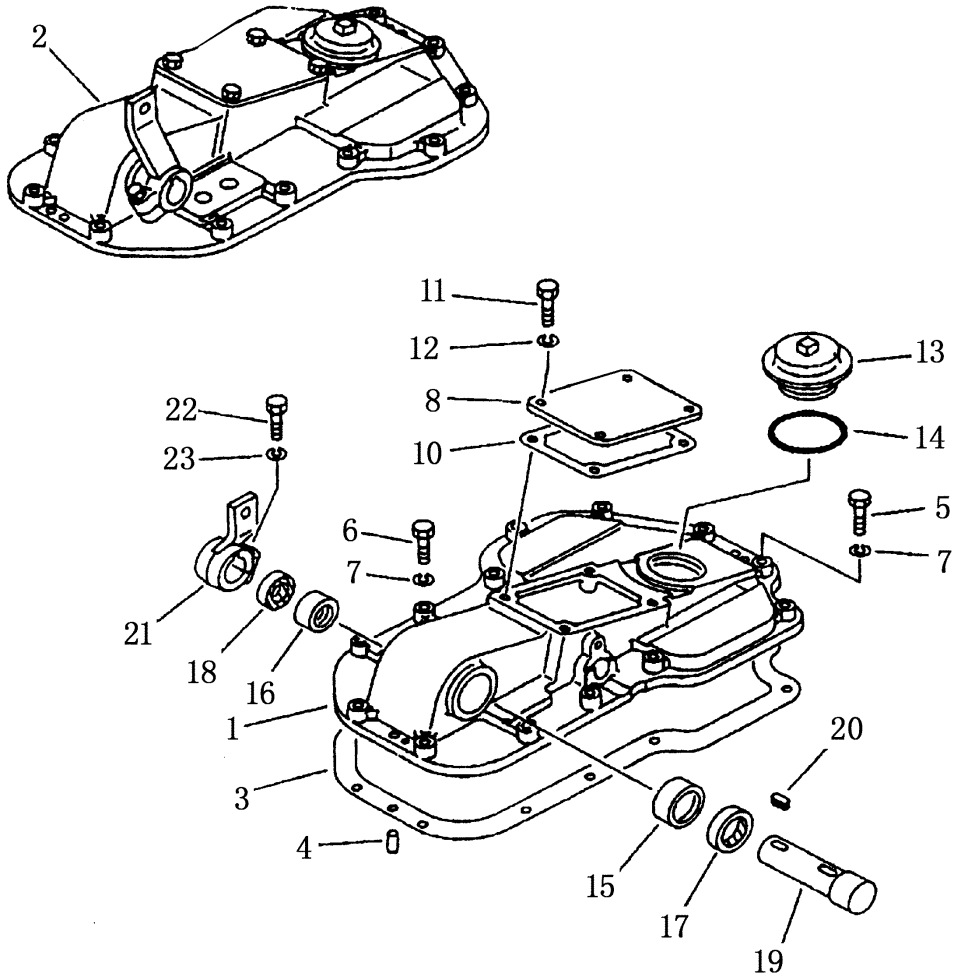

制 动 盖
BRAKEING CASE COVER

序 号 INDEXNO.	件 号 Part No.	名 称 Description	数量 Q'ty
305-1	154-33-31110	刹车盖 (左) cover brake L.H	1
2	154-33-31120	刹车盖 (右) cover brake R.H	1
3	154-33-22191	密封垫 gasket	2
4	04020-01228	定位销 pin dowel	4
5	01010-51245	螺栓 bolt	4
6	01010-51260	螺栓 bolt	22
7	01602-21236	弹簧垫圈 washer spring	26
8	154-33-21441	盖 (左) cover L.H	2
10	154-33-21471	密封垫 gasket	2
11	01010-51230	螺栓 bolt	8
12	01602-21236	弹簧垫圈 washer spring	8
13	154-33-21142	帽 cap	2
14	07000-02095	O 型圈 O-ring	2
15	154-33-21320	衬套 bushing	2
16	154-33-21330	衬套 bushing	2
17	154-33-21340	油封 seal oil	2
18	154-33 21350	油封 seal oil	2
19	154-33-21310	轴 shaft	2
20	04000-01030	键 key	2
21	154-33-31160	摇臂 lever	2
22	01010-51240	螺栓 bolt	2
23	01602-21236	弹簧垫圈 washer spring	2

第 306 图 制动助力器
FIG. 306 BRAKE BOOSTER

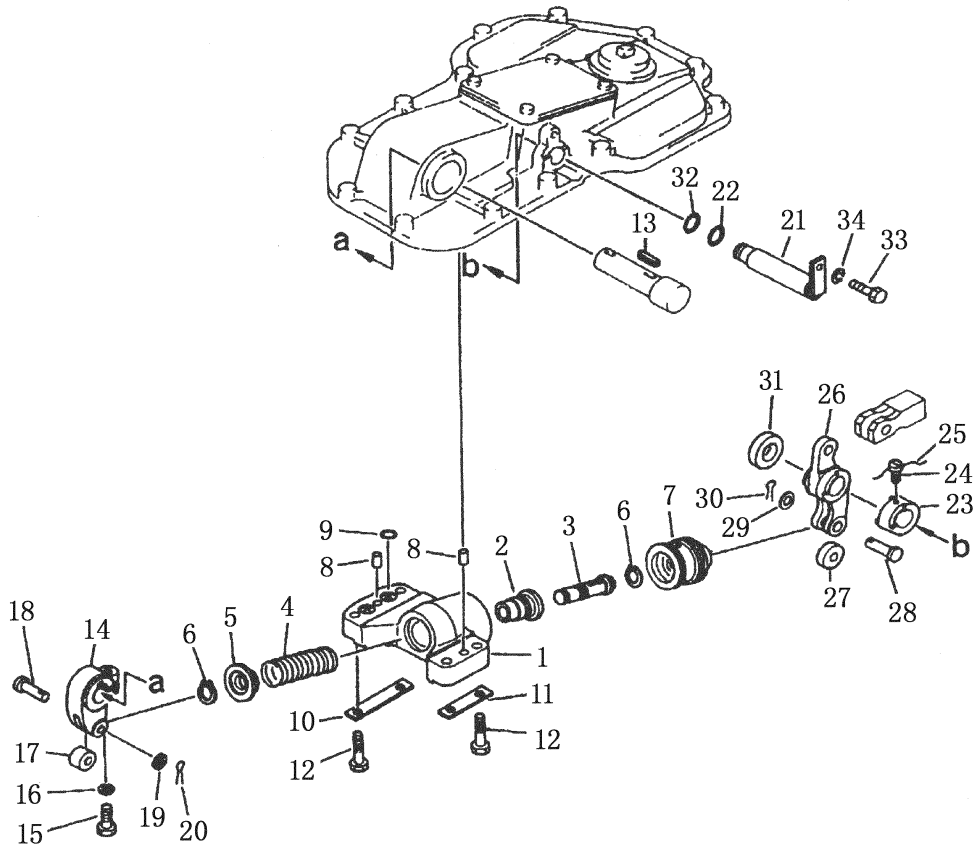

制动助力器
BRAKE BOOSTER

序号 INDEXNO.	件号 Part No.	名称 Description	数量 Q'ty
306-1	154-33-31130	阀体 (左) body L.H	1
	154-33-31140	阀体 (右) body R.H	1
2	195-33-14341	轴套 bushing	2
3	154-33-31180	卷轴 spool	2
4	170-33-13370	弹簧 spring	2
5	175-33-31310	挡圈 ring, stopper	2
6	04064-02512	开口环 ring	2
7	154-33-31150	活塞 piston	2
8	04020-01228	定位销 pin dowel	4
9	07000-02018	O型圈 O-ring	2
10	154-33-21420	锁片 plate lock	2
11	154-33-21430	锁片 plate lock	2
12	01010-81255	螺栓 bolt	8
13	04000-01030	键 key	2
14	154-33-21150	摇臂 lever	2
15	01010-51240	螺栓 bolt	2
16	01602-21236	弹簧垫圈 washer spring	2
17	170-33-13330	滚子 roller	2
18	04205-11645	销 pin	2
19	01641-21626	垫圈 washer	2
20	04050-14025	开口销 pin	2
21	154-33-21262	轴 shaft	2
22	07000-03030	O型圈 O-ring	2
23	154-33-21270	衬套 spacer	2
24	01306-00616	螺钉 screw	2
25	04059-01020	锁紧钢丝 wire lock	2
26	154-33-21161	摇臂 lever	2
27	170-33-13330	滚子 roller	2
28	04205-11645	销 pin	2
29	01641-21626	垫圈 washer	2
30	04050-14025	开口销 pin cotter	2
31	154-33-21280	衬套 spacer	2
32	07000-03025	O型圈 O-ring	2
33	01010-51025	螺栓 bolt	2
34	01602-21030	弹簧垫圈 washer spring	2

第 307 图 终传动箱及齿轮 (1/2)
 FIG. 307 FINAL DRIVE CASE AND GEAR

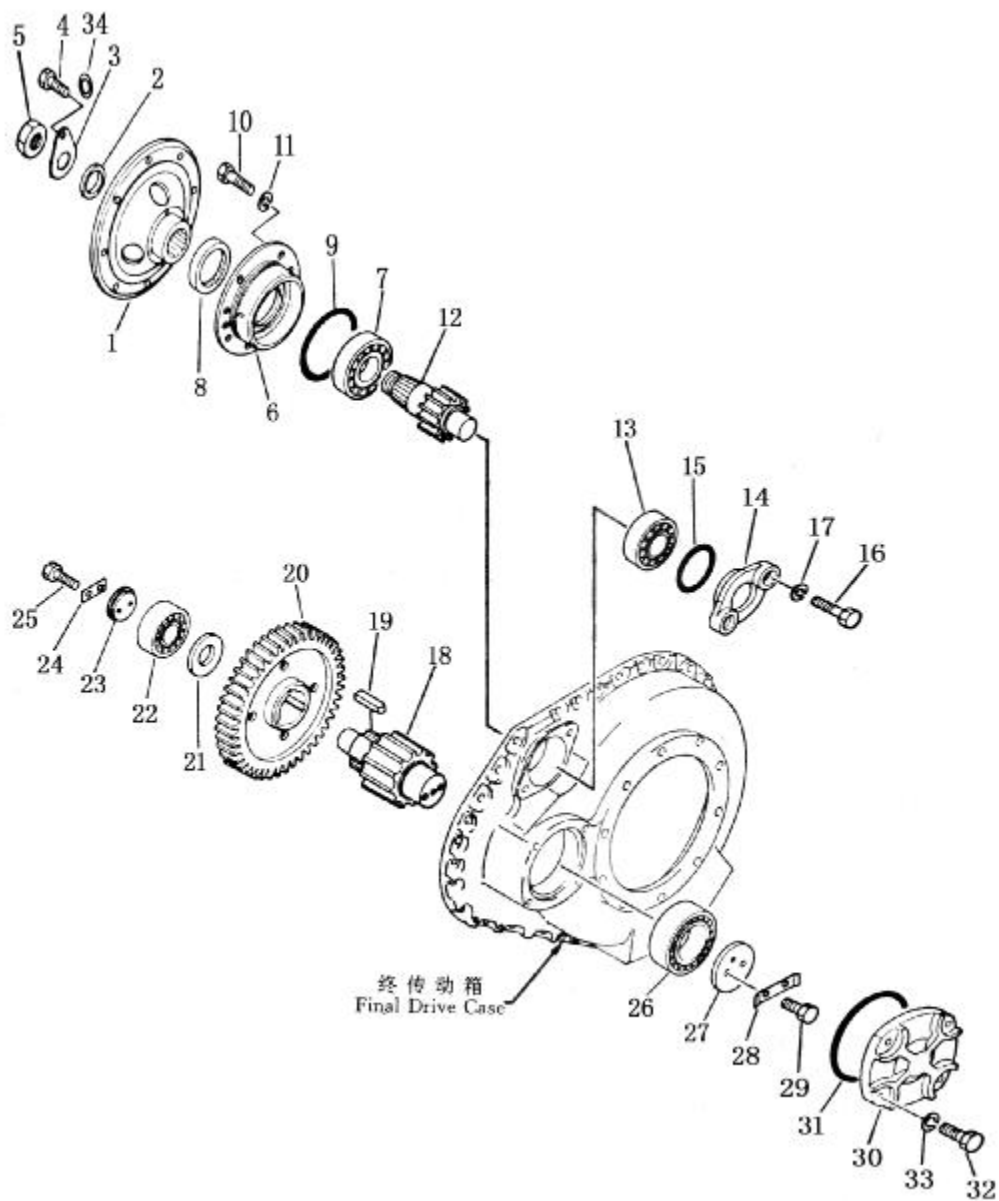

终传动箱及齿轮 (1/2)

FINAL DRIVE CASE AND GEAR

序号 INDEX NO.	图号 PART NO.	名称 DESCRIPTION	数量 QTY
307-1	175-27-31463	法兰盘 flange	2
2	170-27-11232	垫圈 washer	2
3	195-27-12620	锁垫 lock	2
4	01010-51220	螺栓 bolt	2
5	170-21-12141	螺帽 nut	2
6	154-27-11262	轴承座 cage, bearing	2
7	170-09-13160	圆柱滚子轴承 bearing, roller	2
8	07013-10120	油封 seal, oil	2
9	07000-05225	O型圈 o-ring	2
10	01010-51640	螺栓 bolt	16
11	01602-21648	弹簧垫圈 washer, spring	16
12	154-27-11257	小齿轮 (第一级) pinion, first	2
13	150-09-13260	圆柱滚子轴承 bearing, roller	2
14	154-27-11144	盖 cover	2
15	07000-05150	O型圈 o-ring	2
16	01010-52050	螺栓 bolt	4
17	01602-22060	弹簧垫圈 washer, spring	4
18	154-27-11327	小齿轮 (第二级) pinion, second	2
19	154-27-11330	键 key	6
20	154-27-11313	齿轮 (第一级) gear, first	2
21	154-27-21341	隔片 spacer	2
22	150-09-13260	圆柱滚子轴承 bearing, roller	2
23	154-27-11392	内夹板 holder	2
24	154-27-11383	内锁片 lock	2
25	01010-51230	螺栓 bolt	4
26	150-09-13240	圆柱滚子轴承 bearing, roller	2
27	154-27-11373	外夹板 holder	2
28	154-27-11420	外锁片 lock	2
29	01010-51230	螺栓 bolt	4
30	154-27-11191	盖 cover	2
31	07000-05220	O型圈 O-ring	2
32	01010-51640	螺栓 bolt	8
33	01602-21648	弹簧垫圈 washer, spring	8
34	01643-31232	垫圈 washer	2

第 308 图
FIG. 308

终传动箱及齿轮 (2/2)
FINAL DRIVE CASE AND GEAR

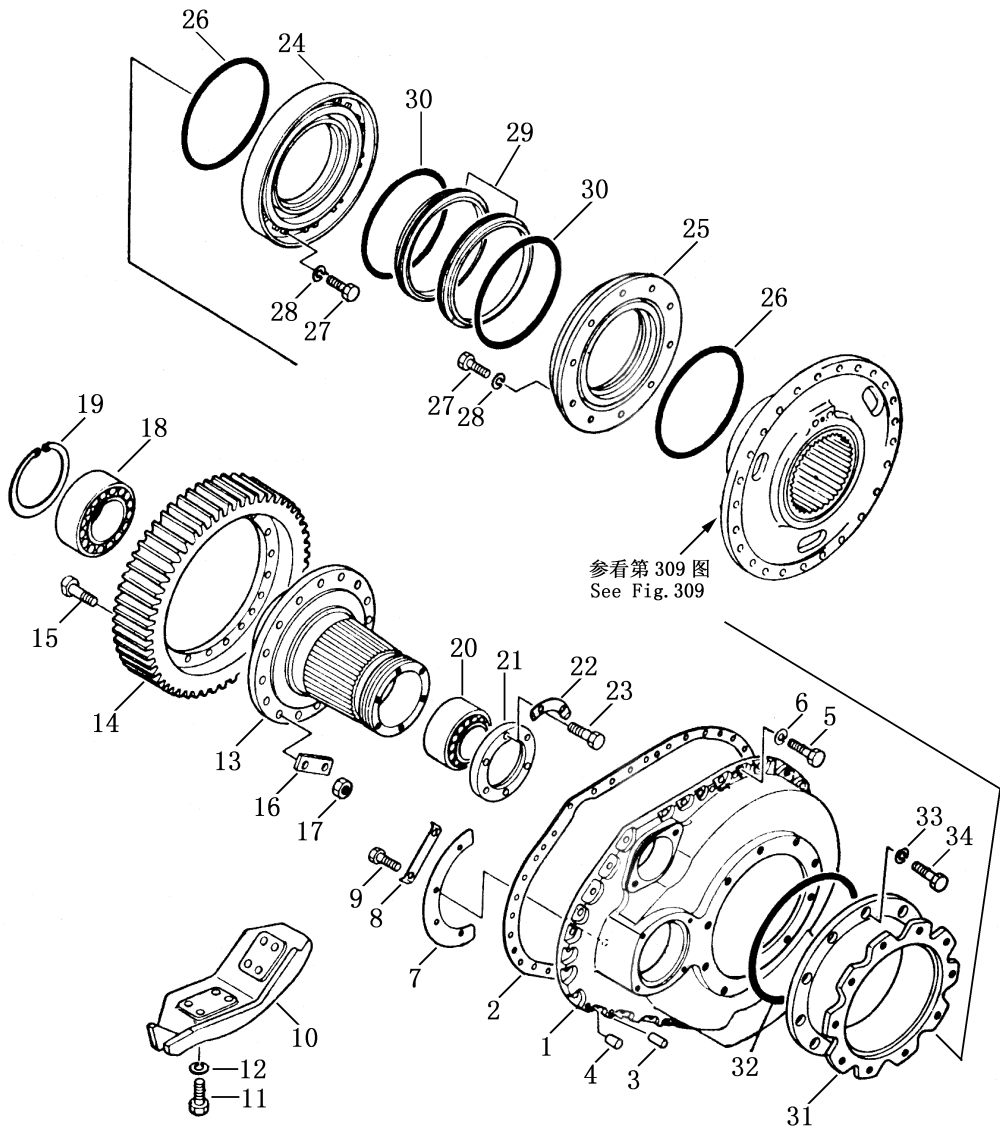

终传动箱及齿轮 (2/2)
FINAL DRIVE CASE AND GEAR

序号 No.	图号 PART NO.	名称 DESCRIPTION	数量 Q'ty	
			SD22, SD22E, SD22D	SD22S
308-1	154-27-11113	左终传动箱 case, final drive L.H.	1	1
	154-27-11123	右终传动箱 case, final drive R.H.	1	1
2	154-27-11130	密封垫 gasket	2	2
3	04020-01842	圆柱销 pin, dowel	4	4
4	07049-02025	螺塞 plug	4	4
5	01010-52050	螺栓 bolt	62	62
6	01602-22060	弹簧垫圈 washer, spring	62	62
7	154-27-11410	板 plate	2	2
8	175-27-31540	锁片 lock	4	4
9	01010-51220	螺栓 bolt	8	8
10	154-27-15110	护板 (左) guard, L.H.	1	1
	154-27-15120	护板 (右) guard, R.H.	1	1
11	01010-52045	螺栓 bolt	16	16
12	01605-12040	垫圈 washer	16	16
13	154-27-12122	齿轮毂 gear, sprocket	2	
	TS220、27-2	齿轮毂 gear, sprocket		2
14	154-27-12110	大齿轮 (第二级) gear, final drive	2	2
15	175-27-12181	铰制孔螺栓 bolt, reamer	32	32
16	175-27-12190	锁片 lock	16	16
17	01582-12419	螺帽 nut	32	32
18	150-09-13110	圆柱滚子轴承 bearing, roller	2	2
19	04071-00250	弹性挡圈 ring, snap	2	2
20	170-09-13250	双列圆柱滚子轴承 bearing, roller	2	2
21	154-27-12560	挡圈 retainer	2	2
22	170-27-12210	锁垫 washer, lock	6	6
23	01010-51440	螺栓 bolt	12	12
24	154-27-12152	盖 cover	2	2
25	154-27-12162	盖 cover	2	2
26	07000-05410	O型圈 O-ring	4	4
27	01010-51230	螺栓 bolt	40	40
28	01602-21236	弹簧垫圈 washer, spring	40	40
	170-27-00021	浮动密封总成 floating seal ass'y	2	2
29	170-27-12513	密封环总成 (由 2 个密封环组成) seal ring ass'y (consists of 2 seal rings)	1	1
30	170-27-12520	O型圈总成 (由 2 个 O型圈组成) O-ring ass'y (consists of 2 O-rings)	1	1
31	TS220.27.1	加长套 bushing		2
32	07000-05410	O型圈 O-ring		1
33	01602-21236	垫圈 washer		20
34	01010-51230	螺栓 bolt		20

第 309 图 链轮及轴
FIG. 309 SPROCKET AND SHAFT

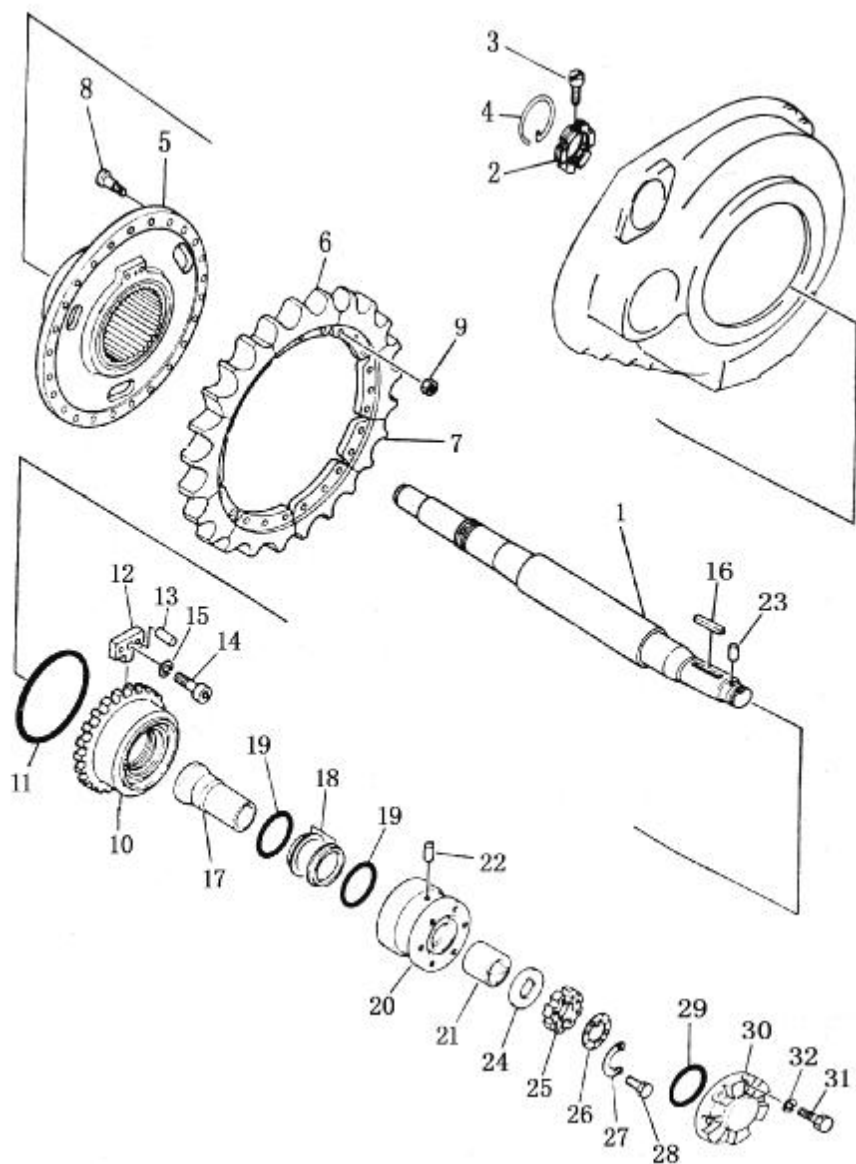

链轮及轴 SPROCKET AND SHAFT

序号 No.	图号 PART NO.	名称 DESCRIPTION	数量 Q' ty	
			SD22, SD22E SD22D	SD22S
309-1	154-27-12313	轴 shaft	2	
	TS220、27-1	轴 shaft		2
2	170-27-12472	螺母 nut	2	2
3	09243-01230	销 pin	2	2
4	170-27-12480	环 ring	2	2
5	154-27-12131	链轮毂 boss, sprocket	2	2
6	154-27-12273	链轮齿 (3 牙) teeth, sprocket, 3 teeth	14	14
7	154-27-12283	链轮齿 (2 牙) teeth, sprocket, 2 teeth	4	4
8	155-27-12181	螺栓 bolt	50	50
9	01803-02228	螺帽 nut	50	50
10	170-27-12232	链轮毂螺帽 nut, hub	2	2
11	07000-05315	O 型圈 o-ring	2	2
12	175-27-31480	锁挡 stopper	2	2
13	170-27-12250	定位销 pin, dowel	4	4
14	01252-41635	螺栓 bolt	2	2
15	01602-21648	弹簧垫圈 washer, spring	2	2
16	04000-01280	键 key	2	2
17	154-27-12352	隔套 spacer	2	2
	198-30-00070	浮动密封总成 floating seal ass' y	2	2
18	198-30-16612	密封环总成(由 2 个密封环组成) seal ring ass' y (consists of 2 seal rings)	1	1
19	170-27-12340	O 型圈总成 (由 2 个 O 型圈组成) O-ring ass' y (consists of 2 o-rings)	1	1
20	154-27-12334	支承 (链轮支架总成) sprocket support ass' y	2	2
21	154-27-12341	轴瓦 bushing	2	2
22	04020-01638	定位销 pin, dowel	2	2
23	175-27-32510	定位销 pin, dowel	2	2
24	154-27-12424	衬垫 spacer	2	2
25	154-27-12412	螺帽 nut	2	2
26	154-27-15240	垫板 plate	2	2
27	154-27-15250	锁板 plate, lock	2	2
28	01010-51020	螺栓 bolt	4	4
29	02892-03148	O 型圈 o-ring	2	2
30	154-27-12362	盖 cover	2	2
31	01010-51640	螺栓 bolt	12	12
32	01602-21648	弹簧垫圈 washer, spring	12	12

第 310 图 转向控制杆
FIG. 310 STEERING CONTROL LEVER

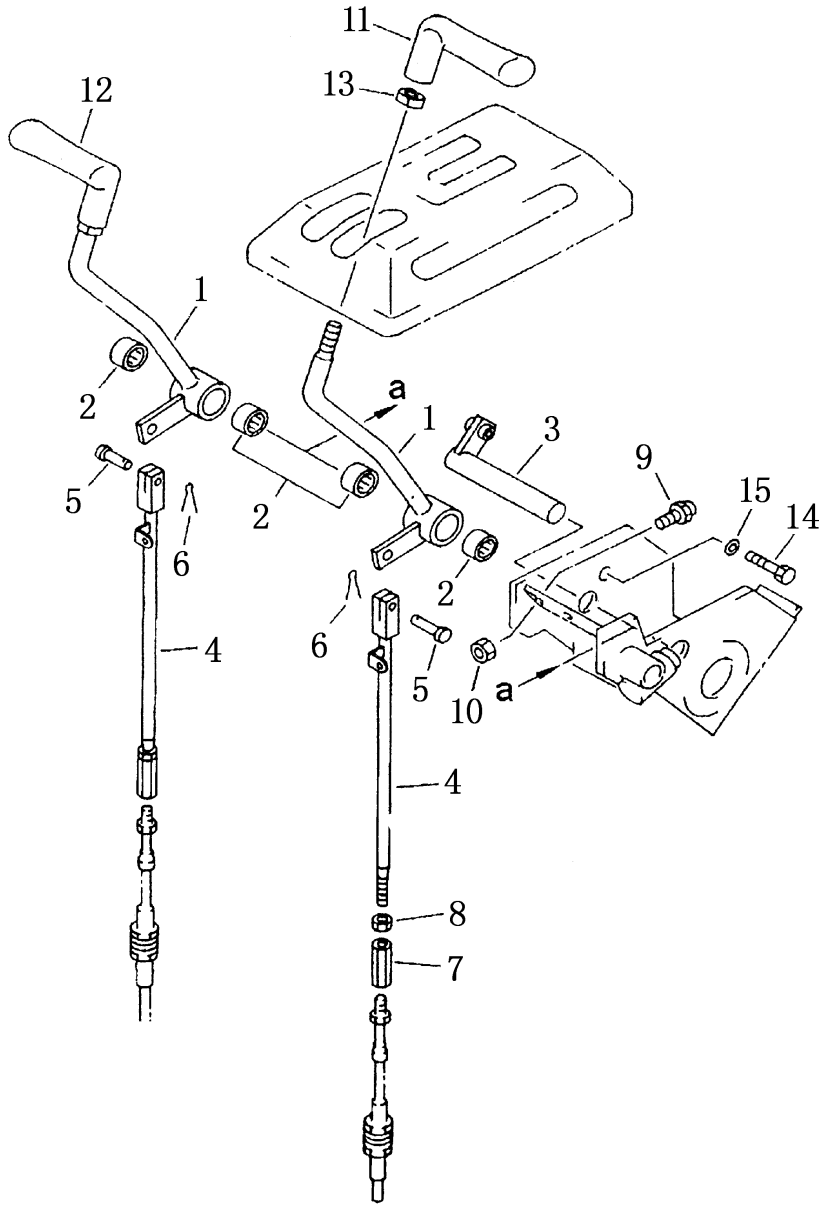

转向控制杆

STEERING CONTROL LEVER

序号 INDEX No.	件号 Part No.	名称 Description	数量 Q' ty
310-1	154-43-42110	摇臂 (左) lever l. h.	1
	154-43-42170	摇臂 (右) lever r. h.	1
2	195-43-43190	轴承 bearing	4
3	17Y-26-04000	轴 shaft	1
4	154-43-42160	杆 rod	2
5	04205-10822	销轴 pin	2
6	04050-12015	开口销 pin cotter	2
7	144-43-51130	接头 joint	2
8	01508-20805	螺母 nut	2
9	195-43-41360	缓冲器 bumper	2
10	01583-11006	螺母 nut	2
11	195-43-41560	手柄 (左) knob l. h.	1
12	195-43-41570	手柄 (右) knob r. h.	1
13	19M-43-11170	螺母 nut	2
14	01010-50816	螺栓 bolt	1
15	01643-30823	垫圈 washer	1

第311图 转向制动连杆(1/2)
 FIG. 311 STEERING AND BRAKE LINKAGE

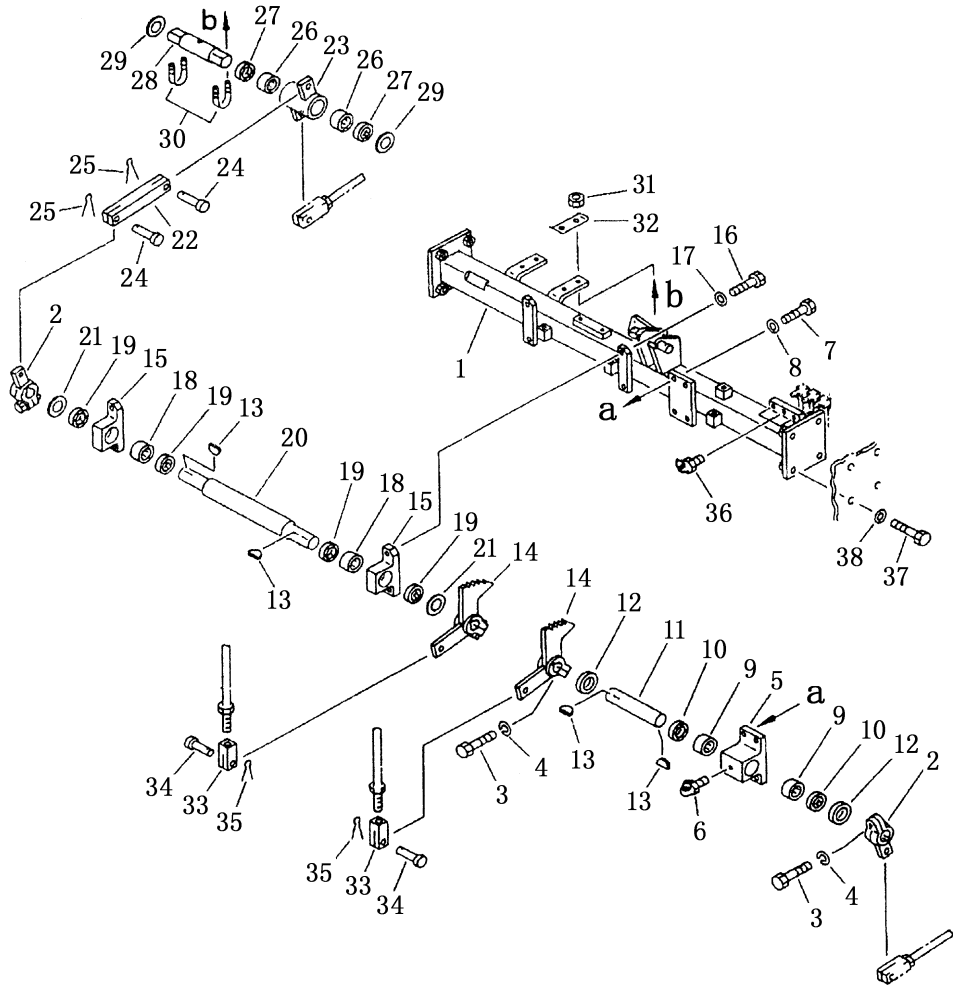

转向制动连杆 (1/2)

STEERING AND BRAKE LINKAGE

序号 INDEX No.	件号 Part No.	名称 Description	数量 Q' ty
311-1	154-43-41251	支架 bracket	1
2	154-43-15581	摇臂 lever	2
3	01010-51245	螺栓 bolt	4
4	01602-21236	弹簧垫圈 washer spring	4
5	154-43-41170	支架 bracket	1
6	07021-01060	油杯 fitting grease	1
7	01010-51230	螺栓 bolt	4
8	01643-31232	垫圈 washer	4
9	06120-03520	滚针轴承 bearing needle	2
10	06122-03504	防尘圈 seal bearing	2
11	154-43-41180	轴 shaft	1
12	195-43-24430	隔垫 spacer	2
13	04010-01032	半圆键 key	4
14	154-43-41160	摇臂 lever	2
15	154-43-41190	支架 bracket	2
16	01010-51230	螺栓 bolt	4
17	01643-31232	垫圈 washer	4
18	06120-03520	滚针轴承 bearing needle	2
19	06122-03504	防尘圈 seal bearing	4
20	154-43-41210	轴 shaft	1
21	154-44-11650	隔垫 spacer	2
22	154-43-41220	叉头 yoke	1
23	154-43-41230	摇臂 lever	1
24	04205-11438	销轴 pin	2
25	04050-14022	开口销 pin cotter	2
26	06120-03520	滚针轴承 pump, bearing needle	2
27	06122-03504	防尘圈 seal bearing	2
28	154-43-41240	轴 shaft	1
29	154-44-11650	隔垫 spacer	2
30	07283-23442	U形管夹 U-clip	2
31	01582-11008	螺母 nut	4
32	154-43-15480	锁片 lock	2
33	04220-21456	叉口板 yoke	2
34	04205-11438	销轴 pin	2
35	04050-14028	开口销 pin cotter	2
36	07021-01060	油杯 fitting grease	3
37	01010-51640	螺栓 bolt	8
38	01643-31645	垫圈 washer	8

第 312 图 转向制动连杆 (2/2)
 FIG. 312 STEERING AND BRAKE LINKAGE

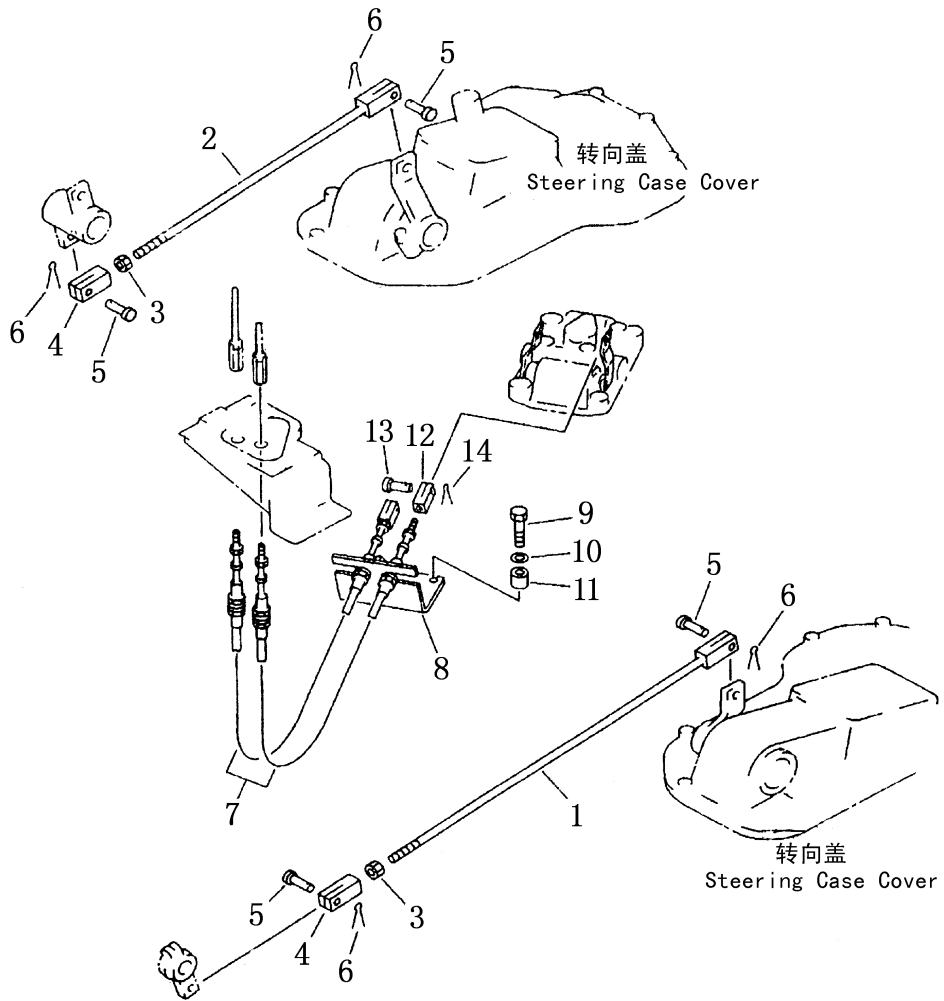

转向制动连杆 (2/2)

STEERING AND BRAKE LINKAGE

序号 INDEX No.	件号 Part No.	名称 Description	数量 Q' ty
312-1	04244-41473	杆 rod	1
2	04244-41456	杆 rod	1
3	01582-11411	螺母 nut	2
4	04210-21456	叉口板 yoke	2
5	04205-11438	销轴 pin	4
6	04050-14022	开口销 pin cotter	4
7	154-43-42130	软轴 cable	2
8	23Y-26B-03000	支座 bracket	1
9	01010-51265	螺栓 bolt	2
10	01643-31232	垫圈 washer	2
11	195-33-11220	衬套 spacer	2
12	195-43-41410	叉口板 yoke	2
13	04205-11235	销轴 pin	2
14	04050-13022	开口销 pin cotter	2

第 313 图 制动踏板
FIG. 313 BRAKE PEDAL

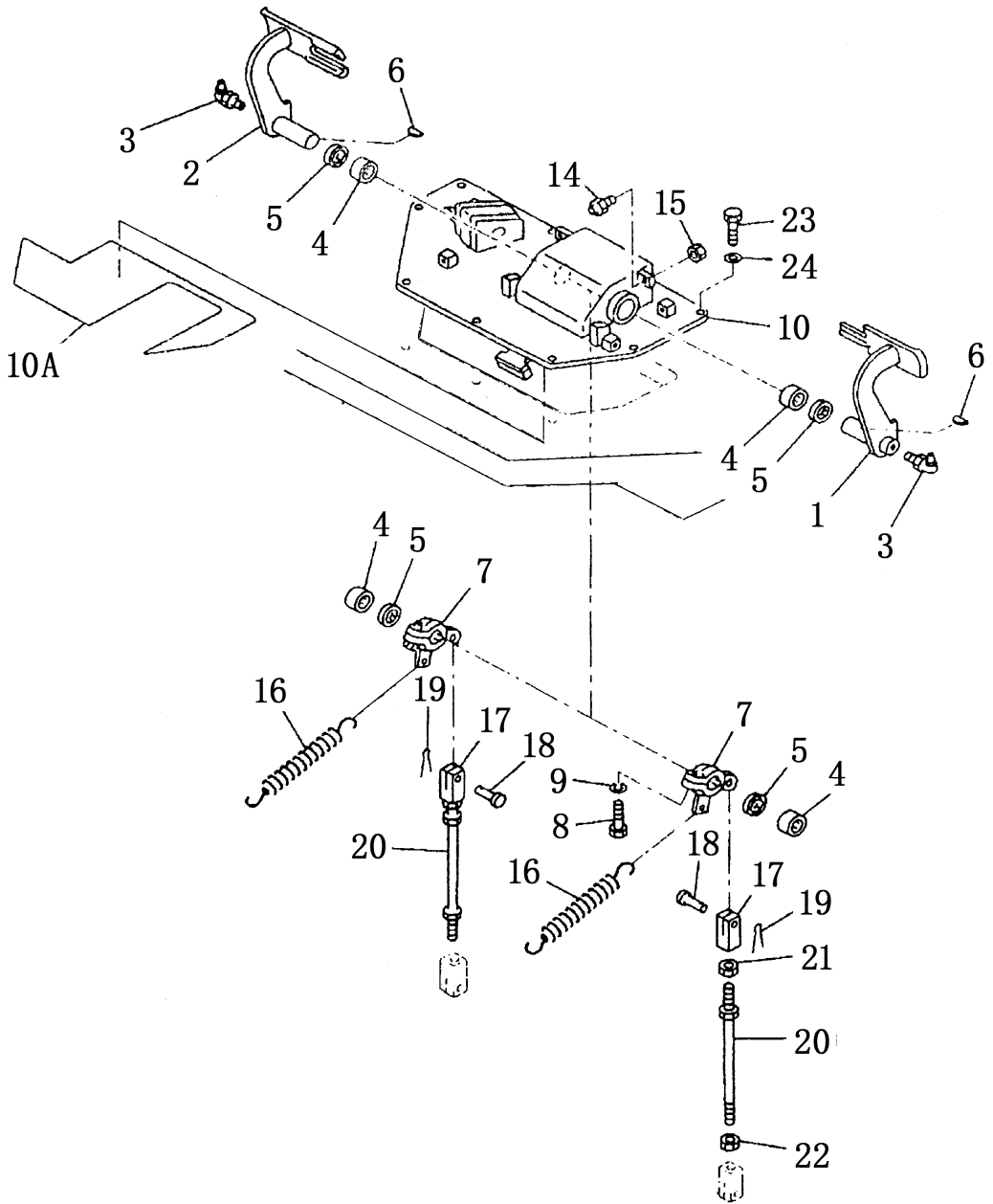

制动踏板
BRAKE PEDAL

序号 INDEX No.	件号 Part No.	名称 Description	数量 Q' ty
313-1	154-43-41130	踏板 (左) pedal l.h.	1
2	154-43-41140	踏板 (右) pedal r.h.	1
3	07021-01090	油杯 fitting grease	2
4	06120-03520	滚针轴承 bearing needle	4
5	06122-03504	防尘圈 seal bearing	4
6	04010-01032	半圆键 key	2
7	154-43-41150	摇臂 lever	2
8	01010-51245	螺栓 bolt	2
9	01602-21236	弹簧垫圈 washer spring	2
10	23Y-26B-01000	支架 bracket	1
10A	154-54-42430	垫片 sheet	1
14	09311-41237	缓冲螺栓 bumper	2
15	01580-11210	螺母 nut	2
16	154-43-41260	弹簧 spring	2
17	04210-21456	叉口板 yoke	2
18	04205-11438	销轴 pin	2
19	04050-14028	开口销 pin cotter	2
20	23Y-26B-05000	杆 rod	2
21	01582-11411	螺母 nut	2
22	01508-41408	螺母 nut	2
23	01010-51230	螺栓 bolt	9
24	01643-31232	垫圈 washer	9

第 314 图 制动闭锁杆
FIG. 314 BRAKE PARKING LEVER

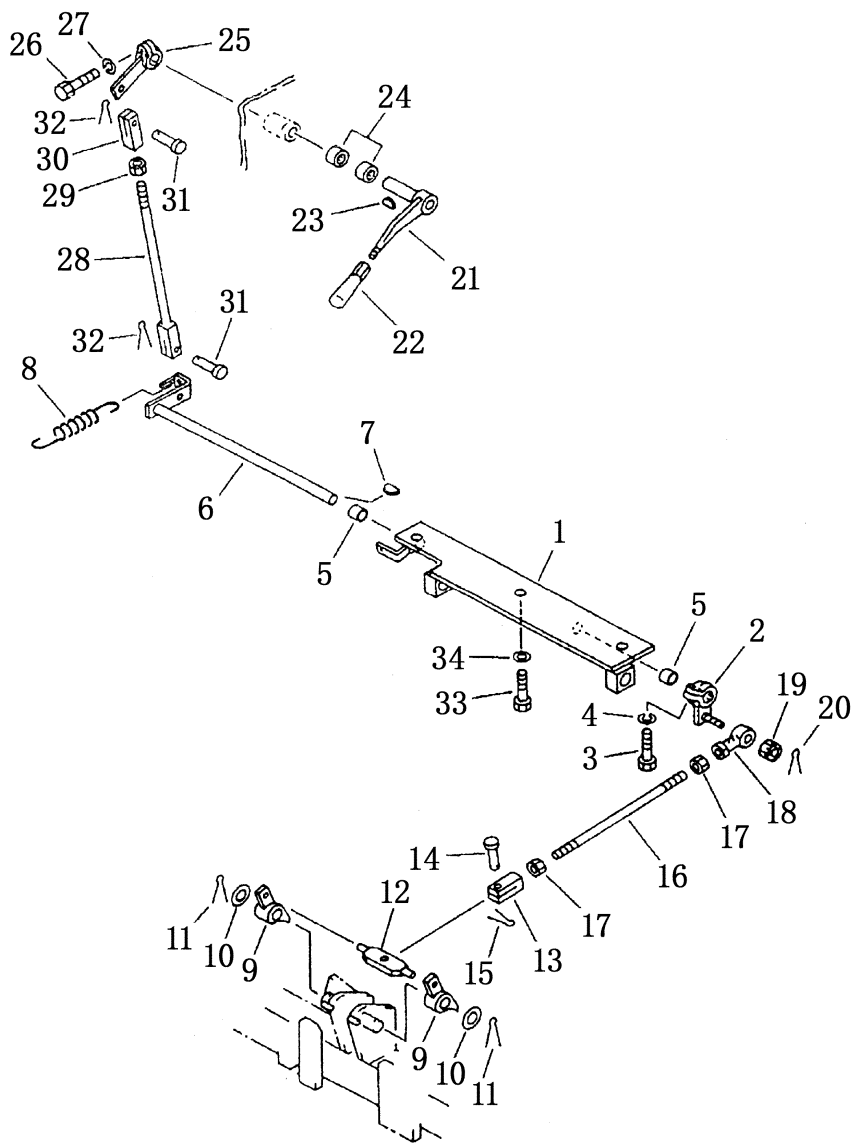

制动闭锁杆

BRAKE PARKING LEVER

序号 INDEX No.	件号 Part No.	名称 Description	数量 Q' ty
314-1	23Y-26B-04000	支架 bracket	1
2	154-43-41340	摇臂 lever	1
3	01010-50830	螺栓 bolt	1
4	01602-20825	垫圈 washer	1
5	09350-01615	衬套 bushing	2
6	23Y-26B-06000	摇臂 lever	1
7	04010-00519	半圆键 key	1
8	195-43-18491	弹簧 spring	1
9	154-43-41360	棘爪 pawl	2
10	01640-22032	垫圈 washer	2
11	04050-14030	开口销 pin cotter	2
12	154-43-41350	棒 bar	1
13	04210-21040	叉口板 yoke	1
14	04205-11028	销轴 pin	1
15	04050-13020	开口销 pin cotter	1
16	04245-41027	杆 rod	1
17	01582-11008	螺母 nut	2
18	04250-81056	关节轴承 end bearing	1
19	01593-11008	螺母 nut	1
20	04050-12018	开口销 pin cotter	1
21	195-43-41260	摇臂 lever	1
22	09305-00800	手柄 knob	1
23	04010-00519	半圆键 key	1
24	195-61-34120	轴承 bearing	2
25	154-43-41310	摇臂 lever	1
26	01010-50830	螺栓 bolt	1
27	01602-20825	垫圈 washer	1
28	23Y-26B-02000,	杆 rod	1
29	01580-11008	螺母 nut	1
30	04210-21040	叉口板 yoke	1
31	04205-11028	销轴 pin	2
32	04050-13020	开口销 pin cotter	2
33	01010-51230	螺栓 bolt	3
34	01643-31232	垫圈 washer	3

第 315 图 转 向 泵
FIG. 315 STEERING PUMP

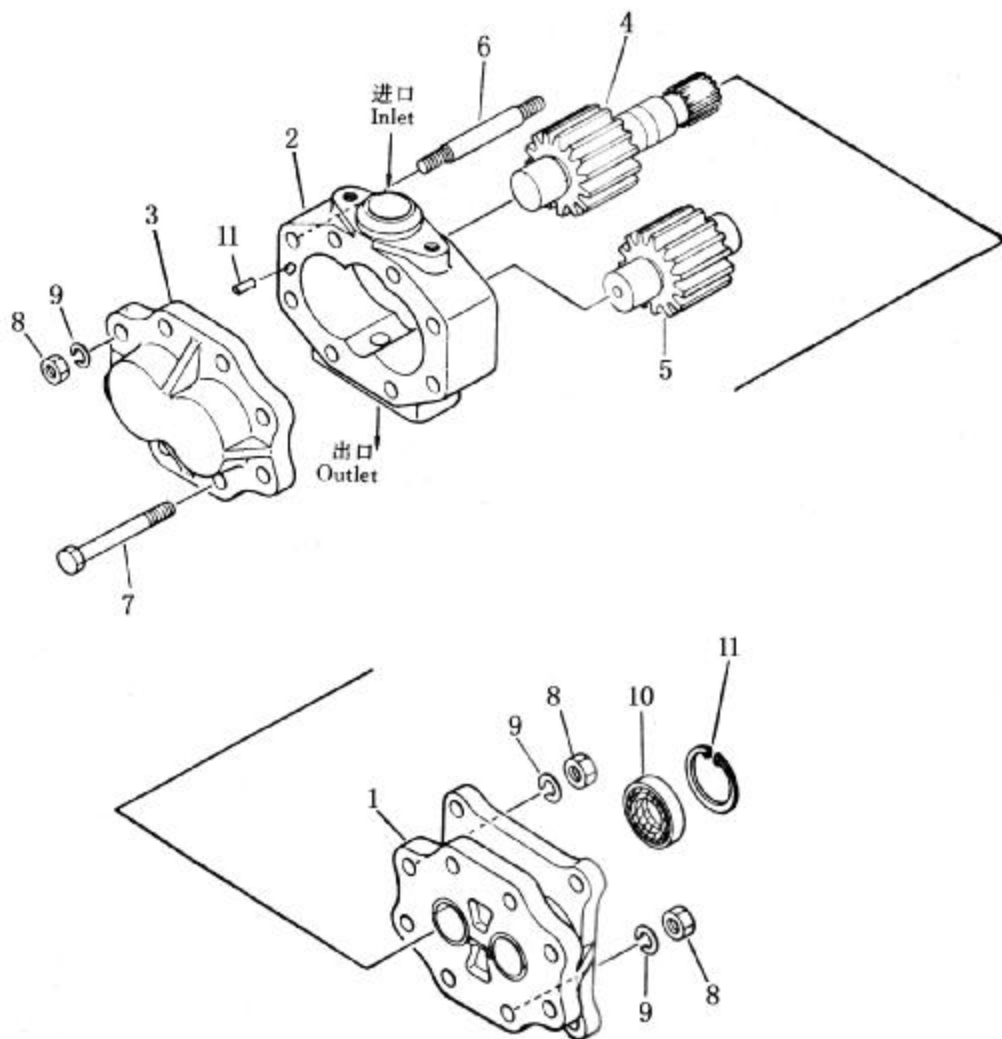

转向泵
STEERING PUMP

序 号 INDEX NO.	图 号 PART NO.	名 称 DESCRIPTION	数量 Q`TY
315-1~9	07436-72202	转向泵总成 steering pump ass' y	1
10	07434-71160	油封 seal, oil	1
11	04020-00820	定位销 pin	4

第 316 图 转 向 阀
 FIG. 316 STEERING CONTROL VALVE

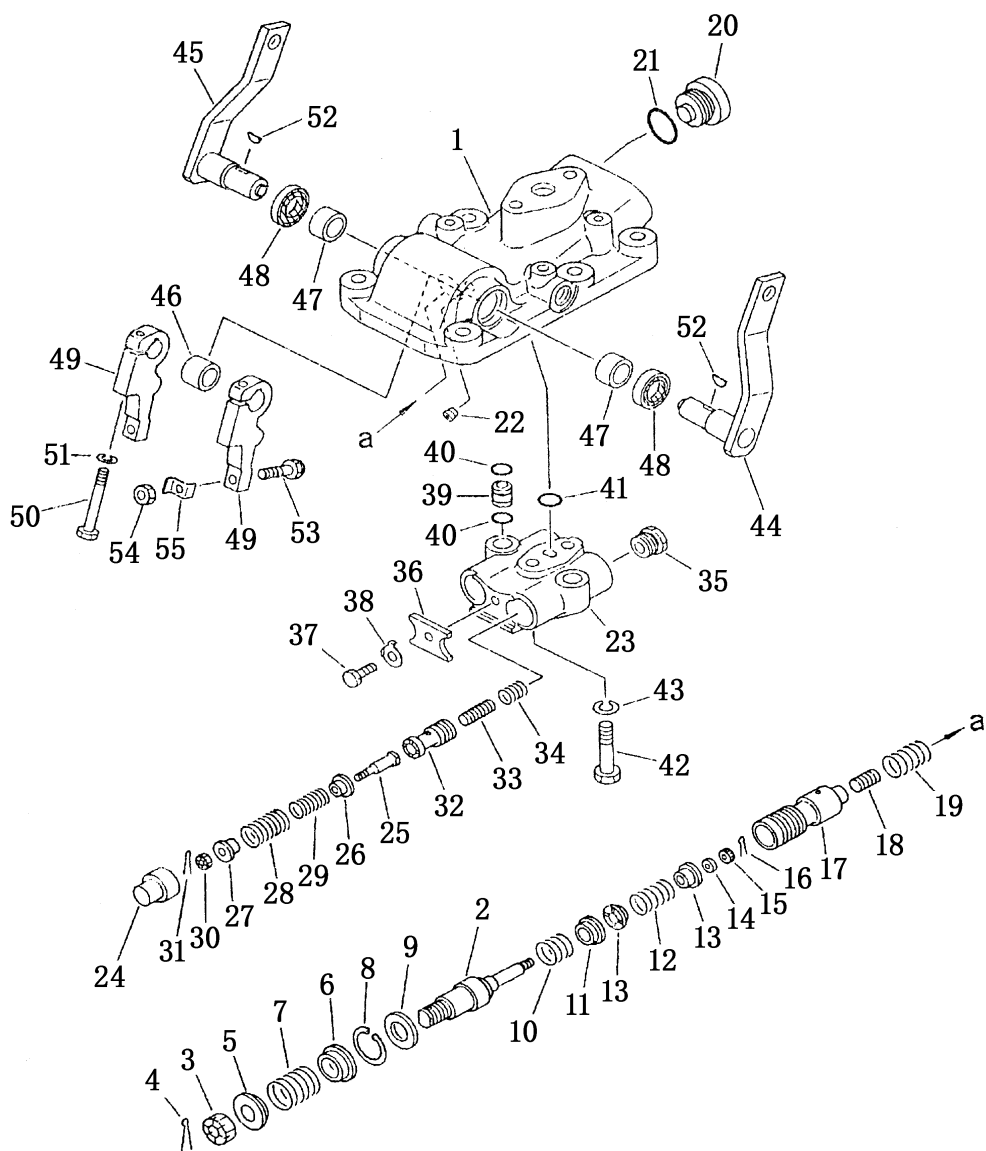

转 向 阀

STEERING CONTROL VALVE

序号 INDEX No.	件 号 Part No.	名 称 Description	数量 Q' ty
	154-40-00082	转向阀 steering valve ass'y	1
316-1	144-40-22211	阀体 body valve	1
2	195-40-11540	轴 shaft	2
3	01593-11613	螺母 nut	2
4	04050-14025	开口销 pin cotter	2
5	144-40-22180	座 stopper	2
6	144-40-22170	座 stopper	2
7	175-40-31230	弹簧 spring	2
8	04065-03212	卡环 ring snap	2
9	195-40-13110	挡圈 stopper	2
10	195-40-11550	弹簧 spring	2
11	195-40-11560	座 stopper	2
12	175-40-31150	弹簧 spring	2
13	195-40-11570	座 stopper	2
14	144-40-22190	垫圈 washer	2
15	01590-10607	螺母 nut	2
16	04050-11212	开口销 pin cotter	2
17	195-40-11531	阀芯 valve	2
18	702-11-11190	活塞 piston	2
19	175-40-31130	弹簧 spring	2
20	175-40-31530	螺塞 plug	2
21	07002-03034	O形圈 o-ring	2
22	07043-50108	螺塞 plug	1
23	144-40-22230	阀体 body valve	1
24	144-40-22290	导套 guide collar	2
25	144-40-22260	轴 shaft	2
26	144-40-22270	座 stopper	2
27	144-40-22280	座 stopper	2
28	144-40-22340	弹簧 spring	2
29	154-40-41130	弹簧 spring	2
30	01590-10607	螺母 nut	2
31	04050-11212	开口销 pin cotter	2
32	144-40-22311	阀芯 valve	2
33	144-40-22320	活塞 piston	2

转 向 阀
STEERING CONTROL VALVE

序号 INDEX No.	件号 Part No.	名称 Description	数量 Q'ty
316-34	175-40-31410	弹簧 spring	2
35	144-40-22250	螺塞 plug	2
36	144-40-22330	板 plate	1
37	01010-50816	螺栓 bolt	1
38	01650-20808	锁片 washer	1
39	175-40-31510	导管 tube	2
40	07000-02011	O形圈 o-ring	4
41	07000-02015	O形圈 o-ring	1
42	01010-51050	螺栓 bolt	2
43	01602-21030	垫圈 washer spring	2
44	154-40-41110	操纵杆(左) lever L.h.	1
45	144-40-41120	操纵杆(右) lever R.h.	1
46	09350-01820	轴套 bushing	1
47	09350-02215	轴套 bushing	2
48	175-40-31270	油封 seal oil	2
49	144-40-22240	杆 lever	2
50	01010-50860	螺栓 bolt	2
51	01602-20825	垫圈 washer spring	2
52	04010-00416	半园键 key	2
53	144-40-22160	螺栓 bolt	2
54	01580-10806	螺母 nut	2
55	130-21-12330	锁片 lock	2

第317图 主调压阀
FIG. 317 MAIN RELIEF VALVE

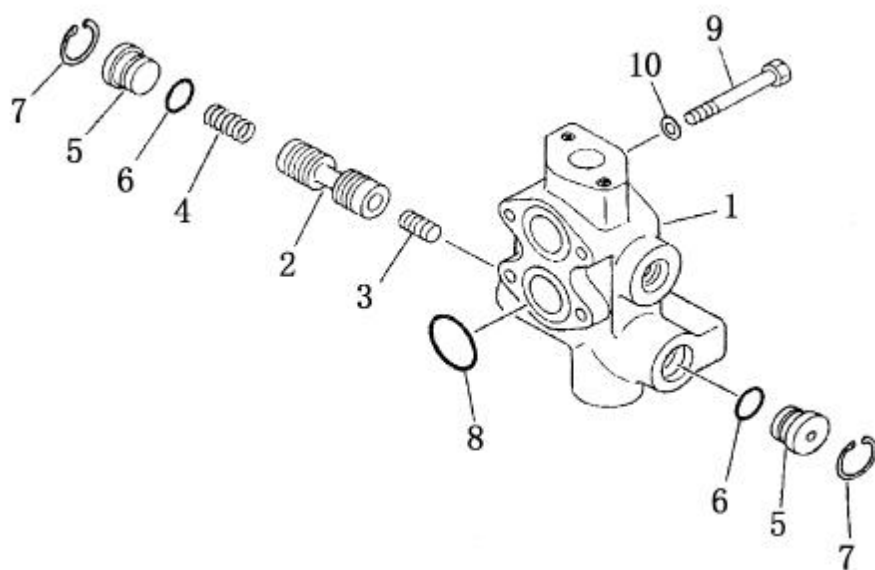

主 调 压 阀
MAIN RELIEF VALVE

序 号 INDEX No.	件 号 Part No.	名 称 Description	数 量 Q' ty
	154-49-51100	调压阀 valve ass'y	1
317-1	154-49-51110	阀体 body valve	1
2	145-14-23710	阀芯 valve	1
3	145-14-23720	柱塞 piston	1
4	195-40-11431	弹簧 spring	1
5	170-33-13530	堵 stopper	2
6	07000-03025	O形圈 o-ring	2
7	04065-03515	挡圈 ring snap	2
8	07000-03042	O形圈 o-ring	2
9	01010-51085	螺栓 bolt	4
10	01643-31032	垫圈 washer	4

第 318 图 精 滤 油 器
FIG. 318 TRANSMISSION OIL FILTER

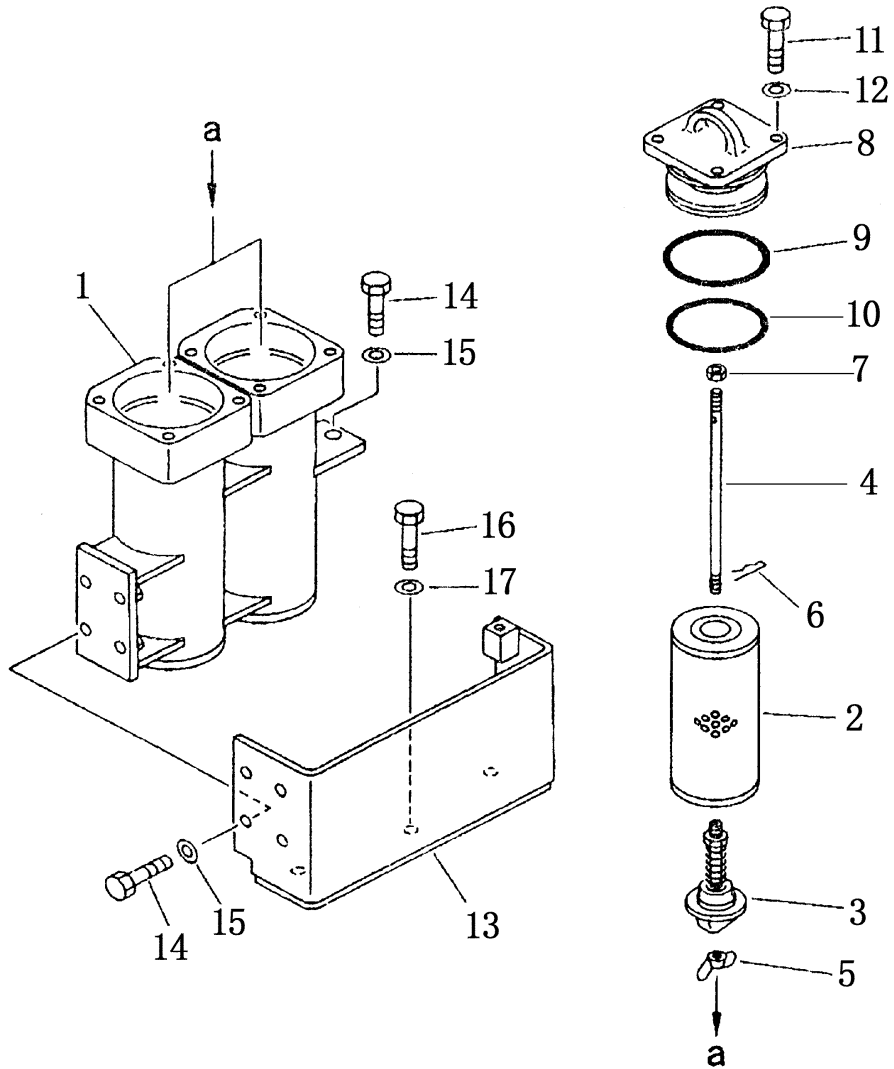

精 滤 油 器

TRANSMISSION OIL FILTER

序 号 INDEX No.	件 号 Part No.	名 称 Description	数量 Q'ty
	154-49-51301	精滤油器 filter ass'y	1
318-1	154-49-51311	滤油器壳 case	1
2	175-49-11580	滤芯 element	2
3	175-49-25530	安全阀 valve ass'y	2
4	175-49-25540	螺杆 rod	2
5	01540-01050	螺帽 nut	2
6	04052-01038	开口销 pin snap	2
7	01582-01008	螺母 nut	2
8	154-49-52130	盖 cover	2
9	07000-02115	O形圈 O-ring	2
10	07000-02110	O形圈 O-ring	2
11	01010-51640	螺栓 bolt	8
12	01643-51645	垫圈 washer	8
13	154-49-51320	板 bracket	1
14	01010-51230	螺栓 bolt	5
15	01643-31232	垫圈 washer	5
16	01010-51635	螺母 nut	3
17	01643-31645	垫圈 washer	3

第 319 图 粗滤油器
FIG. 319 OIL STRAINER

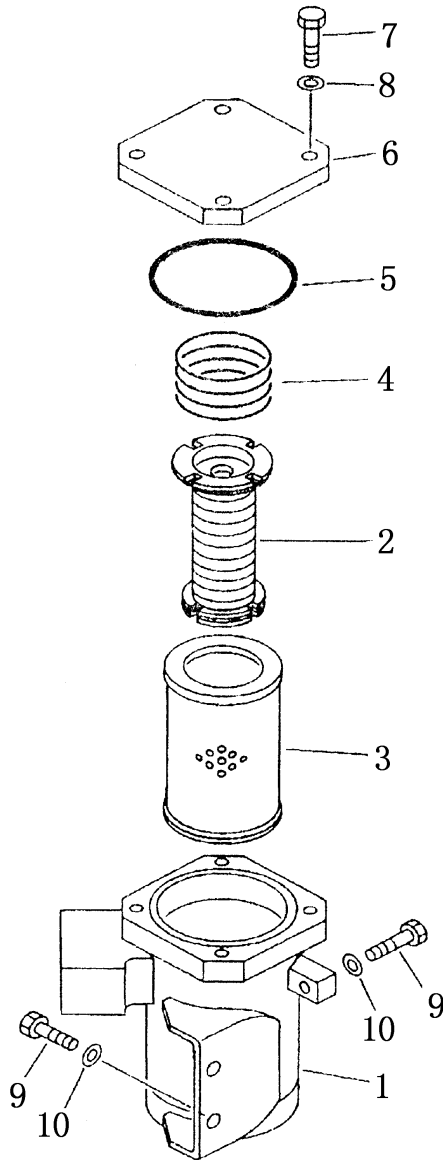

粗滤油器
OIL STRAINER

序号 INDEX No.	件号 Part No.	名称 Description	数量 Q'ty
	154-49-51200	粗滤油器 strainer ass'y	1
319-1	154-49-51211	滤油器壳 case	1
2	175-49-11231	磁铁 magnet ass'y	1
3	175-49-11222	滤芯 screen	1
4	154-19-11230	弹簧 spring	1
5	07000-03130	O形圈 o-ring	1
6	154-49-51220	盖 cover	1
7	01010-51235	螺栓 bolt	4
8	01643-31232	垫圈 washer	4
9	01010-51235	螺栓 bolt	3
10	01643-31232	垫圈 washer	3

第 320 图 转向管路 (1/3)
FIG. 320 STEERING PIPING

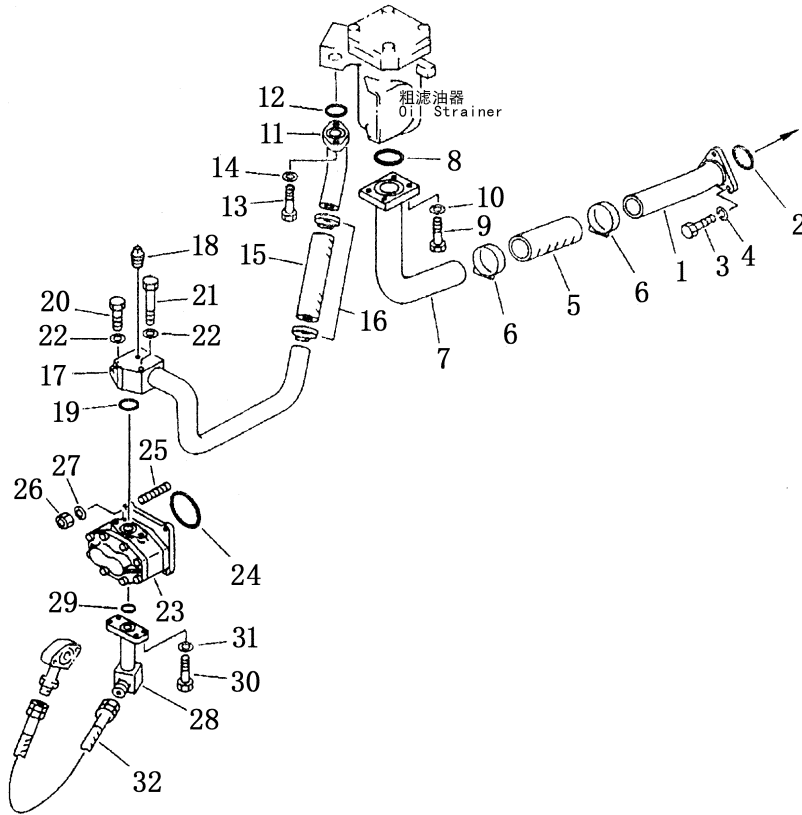

转向管路 (1/3)
STEERING PIPING

序号 INDEX No.	件号 Part No.	名称 Description	数量 Q'ty
320-1	154-49-51120	管 tube	1
2	07000-02065	O形圈 o-ring	1
3	01010-51235	螺栓 bolt	3
4	01602-21236	垫圈 washer spring	3
5	07260-05825	软管 hose	1
6	07280-08029	管夹 clamp	4
7	154-49-51130	管 tube	1
8	07000-02060	O形圈 o-ring	1
9	01010-51240	螺栓 bolt	4
10	01643-31232	垫圈 washer	4
11	154-49-51141	管 tube	1
12	07000-03042	O形圈 o-ring	1
13	01010-51240	螺栓 bolt	2
14	01643-31232	垫圈 washer	2
15	07260-04120	软管 hose	1
16	07281-00609	喉箍 clamp hose	2
17	154-49-51150	管 tube	1
18	07042-30108	螺塞 plug	1
19	07000-03038	O形圈 o-ring	1
20	01010-51035	螺栓 bolt	1
21	01010-51080	螺栓 bolt	1
22	01643-31032	垫圈 washer spring	2
23	07436-72202	转向泵 pump ass'y	1
24	07000-02085	O形圈 o-ring	1
25	01140-51255	螺栓 bolt	4
26	01582-11210	螺母 nut	4
27	01643-31232	垫圈 washer	4
28	154-49-51231	管 tube	1
29	07000-03025	O形圈 o-ring	1
30	01010-51035	螺栓 bolt	4
31	01643-31032	垫圈 washer	4
32	07102-20605	软管 hose	1

第 321 图 转向管路 (2/3)
FIG. 321 STEERING PIPING

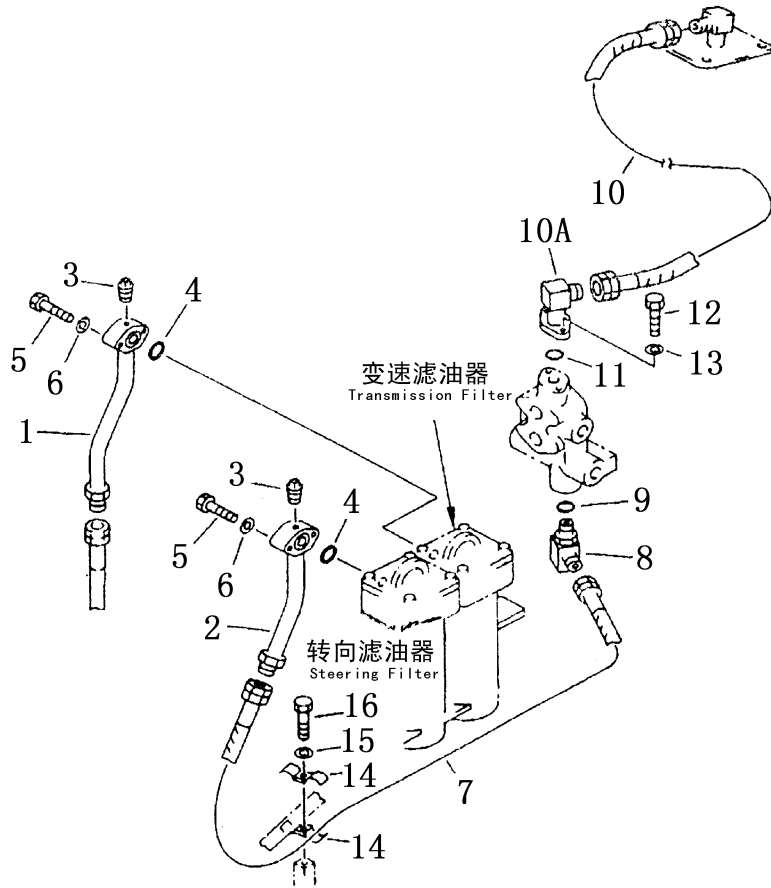

转向管路 (2/3)
STEERING PIPING (2/3)

序号 INDEX No.	件号 Part No.	名称 Description	数量 Q'ty
321-1	154-49-51250	管 tube	1
2	154-49-51760	管 tube	1
3	07042-30108	螺塞 plug	2
4	07000-03035	O形圈 O-ring	2
5	01010-51045	螺栓 bolt	4
6	01643-31032	垫圈 washer spring	4
7	07102-20614	软管 hose	1
8	154-49-51270	管接头 elbow	1
9	07002-02434	O形圈 O-ring	1
10	07102-21010	软管 hose	1
10A	23Y-74B-04000	管 tube	1
11	07000-03032	O形圈 O-ring	2
12	01010-51035	螺栓 bolt	2
13	01643-31032	垫圈 washer	2
14	176-61-41420	管夹 clamp	2
15	01010-51055	螺栓 bolt	1
16	01643-31032	垫圈 washer	1

第 322 图 转向管路 (3/3)
FIG. 322 STEERING PIPING

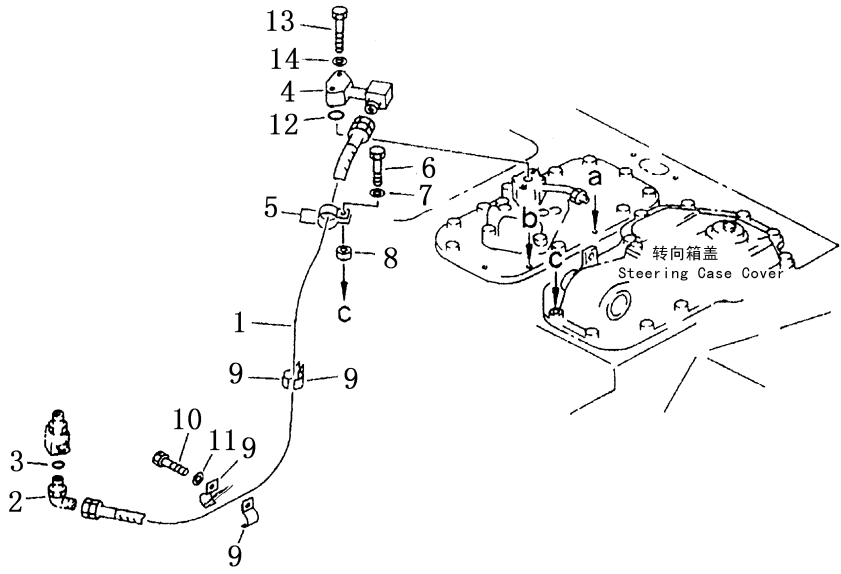

转向管路 (3/3)
STEERING PIPING

序号 INDEX No.	件号 Part No.	名称 Description	数量 Q'ty
322-1	07102-20616	软管 hose	1
2	07235-10628	接头 elbow	1
3	07002-02434	O形圈 O-ring	1
4	23Y-74B-01000	管 tube	1
5	154-49-51970	管夹 clamp	2
6	01010-51290	螺栓 bolt	1
7	01643-31232	垫圈 washer	1
8	195-33-11220	套 spacer	1
9	154-49-51970	管夹 clamp	4
10	01010-51230	螺栓 bolt	2
11	01643-31232	垫圈 washer	2
12	07000-03028	O形圈 O-ring	1
13	01011-51020	螺栓 bolt	2
14	01643-30032	垫圈 washer	2

第 323 图 制动管路
 FIG. 323 BRAKE PIPING

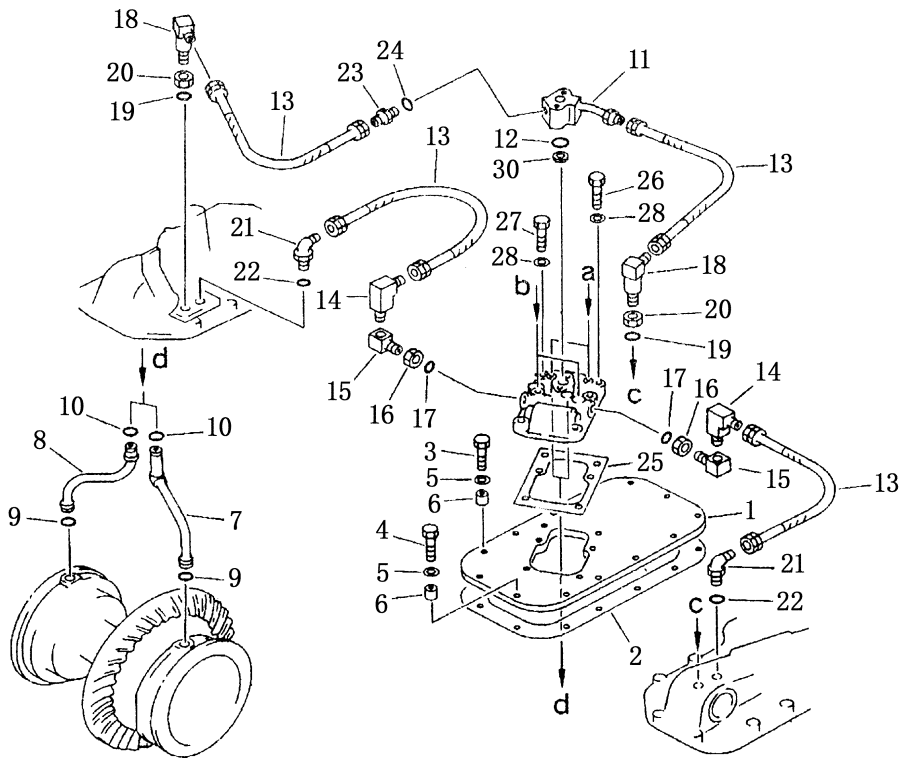

制动管路 BRAKE PIPING

序号 INDEX No.	件号 Part No.	名称 Description	数量 Q'ty
323-1	154-49-51560	板 plate	1
2	175-40-22591	垫 gasket	1
3	01010-51260	螺栓 bolt	10
4	01010-51265	螺栓 bolt	3
5	01643-31232	垫圈 washer	13
6	195-33-11220	套 spacer	13
7	154-49-51651	管(左) tube l.h.	1
8	154-49-51660	管(右) tube r.h.	1
9	07000-03022	O形圈 O-ring	2
10	07000-02018	O形圈 O-ring	2
11	154-49-51570	管 tube	1
12	07000-03028	O形圈 O-ring	1
13	07102-20303	软管 hose	4
14	203-62-12330	接头 elbow	2
15	195-49-13830	接头 elbow	2
16	195-49-13840	螺母 nut	2
17	07002-01623	O形圈 O-ring	2
18	175-49-25670	接头 elbow	2
19	07002-02034	O形圈 O-ring	2
20	01583-12012	螺母 nut	2
21	07235-10315	接头 elbow	2
22	07002-02034	O形圈 O-ring	2
23	07230-20315	接头 elbow	1
24	07002-02034	O形圈 O-ring	1
25	144-40-22221	垫 gasket	1
26	01010-51250	螺栓 bolt	5
27	01010-51240	螺栓 bolt	1
28	01643-31232	垫圈 washer	6
29	154-49-51510	块 bar	1
30	154-49-51630	垫 gasket	1

第 324 图 集中润滑管路
FIG. 324 CONCENTRATED PIPING

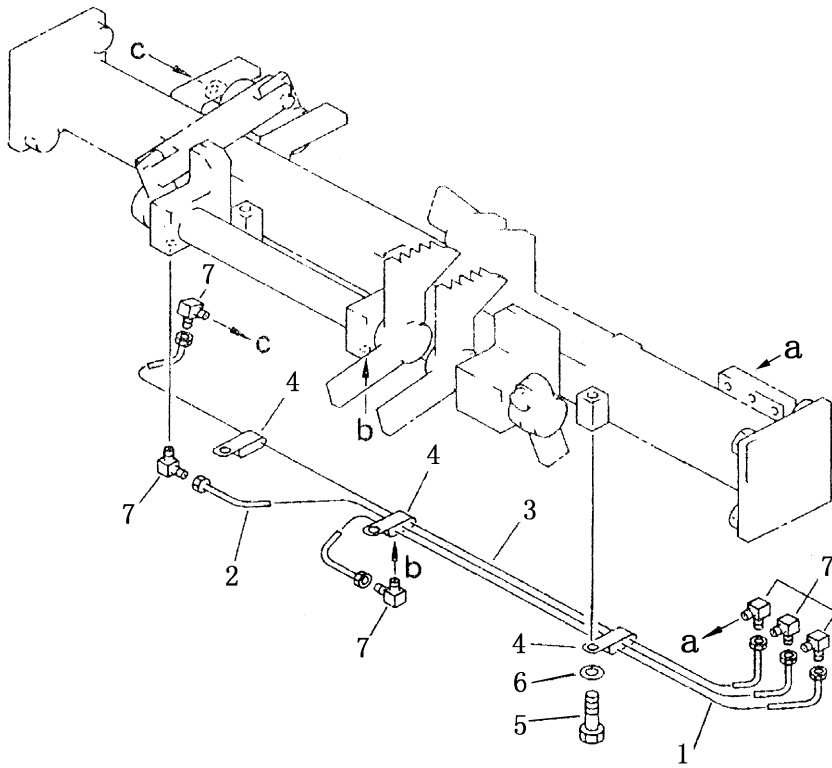

集中润滑管路
CONCENTRATED PIPING

序号 INDEX No.	件号 Part No.	名称 Description	数量 Q'ty
324-1	154-43-41410	管 tube	1
2	154-43-41420	管 tube	1
3	154-43-41430	管 tube	1
4	209-38-12260	夹 clip	3
5	01010-51220	螺栓 bolt	3
6	01643-31232	垫圈 washer	3
7	176-43-41350	接头 elbow	6

第 325 图 测压管路
 FIG. 325 TEST PRESSURE PIPING

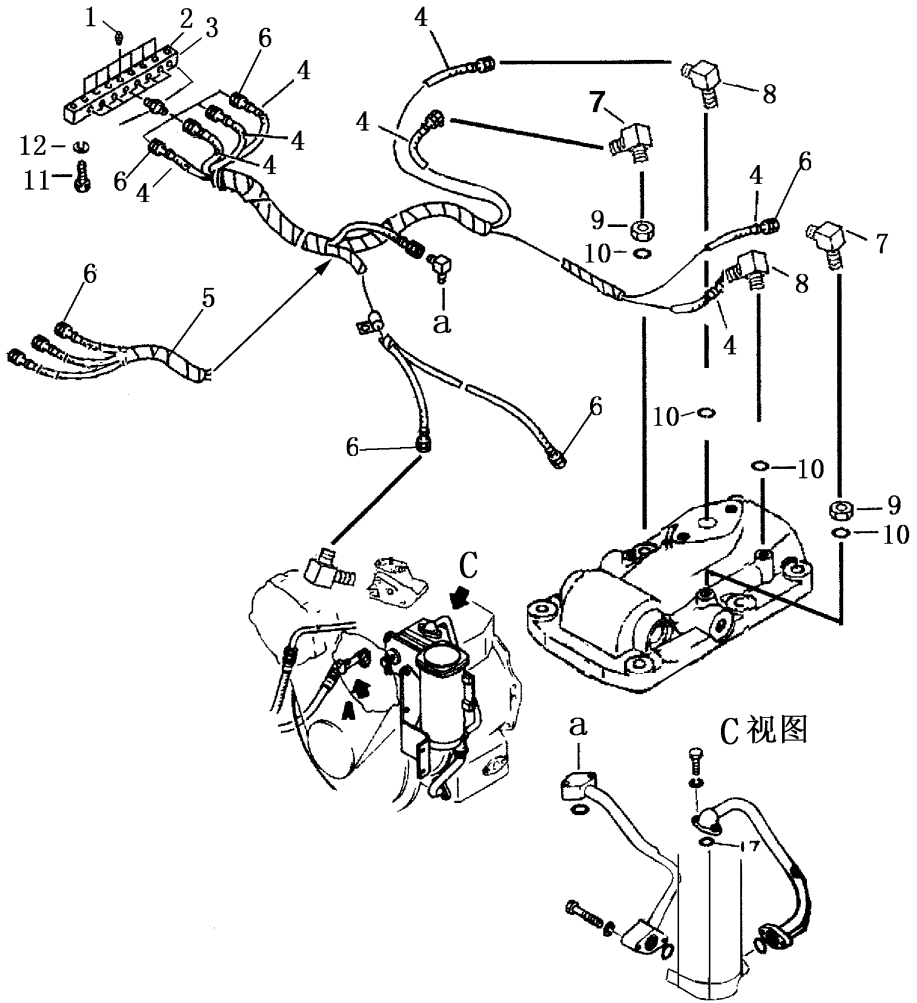

测压管路

TEST PRESSURE PIPING

序号 INDEX No.	件号 Part No.	名称 Description	数量 Q'ty
1	07042-20108	螺塞 plug	10
2	17Y-74B-00003	测压座 seat	1
3	17Y-74B-00004	测压标牌 plate	1
4	17Y-74B-01000	软管 hose	1
5	17Y-74B-02000	软管 hose	1
6	17Y-74B-00001	接头 elbow	10
7	17Y-74B-00002	弯头 elbow	2
8	23Y-75B-00001	接头 elbow	2
9	01580-10806	螺母 nut	2
10	07002-00823	O型圈 O-ring	4
11	01010-51245	螺栓 bolt	2
12	01643-31232	垫圈 washer	2

行走装置

TRACK MECHANISM

第 401 图 台车架
FIG. 401 TRACK FRAME

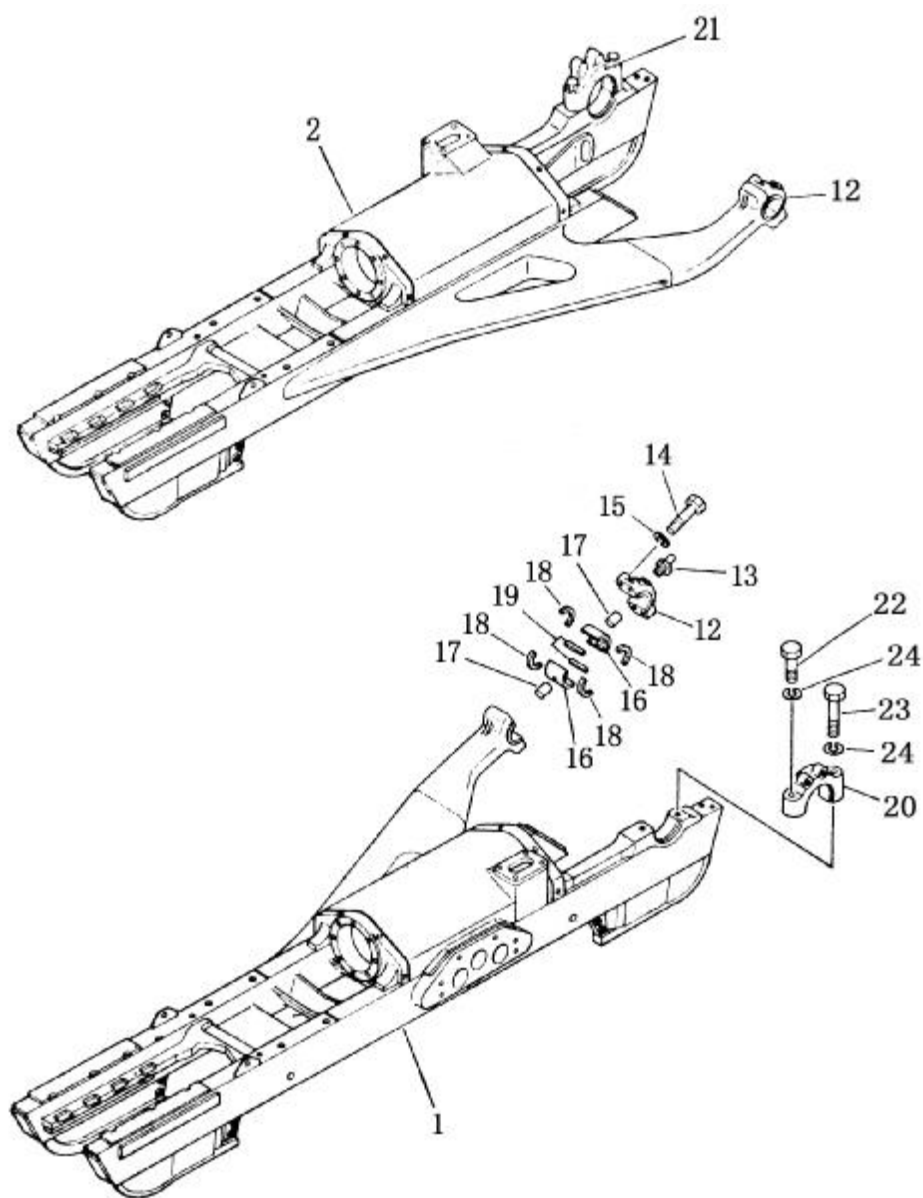

台车架
TRACK FRAME

序号 Index No.	件 号 Part No.	名 称 Description	数量 Q' ty		
			SD22	SD22E SD22D	SD22S
401-1	154-30-14112	台车架 (左) frame, track, L. H.	1		
	23Y-40E-02000	台车架 (左) frame, track, L. H.		1	
	TS220. 30. 2	台车架 (左) frame, track, L. H.			1
2	154-30-14122	台车架 (右) frame, track, R. H.	1		
	23Y-40E-01000	台车架 (右) frame, track, R. H.		1	
	TS220. 30. 2	台车架 (右) frame, track, R. H.			1
12	154-30-11612	盖 cap	2	2	2
13	07020-00000	滑脂咀 fitting, grease	2	2	2
14	01011-52400	螺栓 bolt	8	8	8
15	01602-22472	垫圈 washer	8	8	8
16	154-30-11810	轴瓦 bushing	4	4	4
17	04020-01024	定位销 pin, dowel	4	4	4
18	154-30-11821	密封圈 packing	8	8	8
19	154-30-11831	密封圈 packing	4	4	4
20	154-30-12530	轴承盖 (左) cap, support, L. H.	1	1	1
21	154-30-12540	轴承盖 (右) cap, support, R. H.	1	1	1
22	01011-52410	螺栓 bolt	2	2	2
23	01011-52450	螺栓 bolt	2	2	2
24	01602-22472	垫圈 washer	4	4	4

第 402 图 涨紧装置
FIG. 402 RECOIL MECHANISM

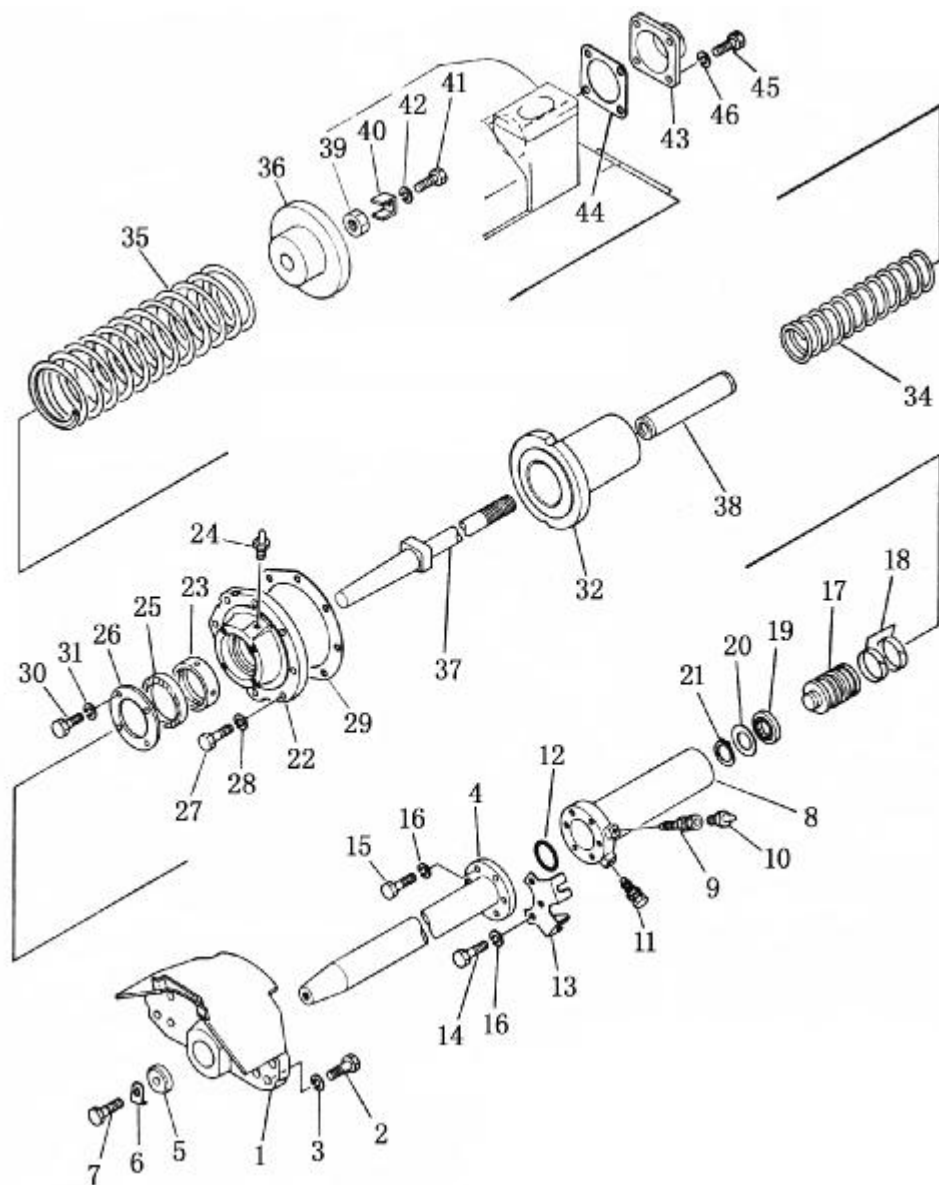

涨紧装置

RECOIL MECHANISM

序号 Index No.	件号 Part No.	名称 Description	数量 Q' ty		
			SD22	SD22E SD22D	SD22S
402-1	154-30-11497	支座 yoke	2	2	2
2	01010-52065	螺栓 bolt	16	16	16
3	01602-22060	垫圈 washer	16	16	16
4	154-30-11134	轴 shaft	2		
	23Y-40E-03000	轴 shaft		2	
	TS220.30.3	轴 shaft			2
5	154-30-11332	垫圈 washer	2	2	2
6	154-30-11540	锁垫 lock	2	2	2
7	01010-52050	螺栓 bolt	2	2	2
8	154-30-11540	油缸 cylinder	2	2	2
9	195-30-13191	注油器 lubricator	2	2	2
10	07020-00000	直通式油杯 M10×1 fitting, grease	2	2	2
11	198-30-14420	油塞 plug	2	2	2
12	07000-15070	O型圈 o-ring	2	2	2
13	154-30-12321	护罩 cover, stopper	2	2	2
14, 15	01010-51240	螺栓 bolt	12	12	12
16	01602-21236	弹簧垫圈 washer, spring	12	12	12
17	154-30-11771	活塞 piston	2	2	2
18	150-30-13430	活塞环 ring	4	4	4
19	150-30-13442	油封 packing	2	2	2
20	150-30-13480	环 ring	2	2	2
21	150-30-13460	挡圈 ring, snap	2	2	2
22	154-30-11153	盖 cover	2	2	2
23	154-30-12170	衬套 bushing	2	2	2
24	07020-00000	直通式油杯 M10×1 fitting, grease	2	2	2
25	07019-00100	油封 packing	2	2	2
26	154-30-11192	挡板 plate	2	2	2
27	01010-52060	螺栓 bolt	16	16	16

涨紧装置
RECOIL MECHANISM

序 号 Index No.	件 号 Part No.	名 称 Description	数 量 Q' ty
402-28	01602-22060	垫圈 washer	16
29	154-30-11212	密封垫 packing	2
30	01010-51022	螺栓 bolt	8
31	01602-21030	弹簧垫圈 washer, spring	8
32	154-30-11174	导套 pilot	2
34	154-30-12770	小弹簧 spring, small	2
35	154-30-11752	大弹簧 spring, recoil, large	2
36	154-30-11242	导向座 pilot	2
37	154-30-11224	拉杆 shaft	2
38	154-30-11234	限位管 stopper	2
39	01580-13629	螺帽 nut	2
40	154-30-11763	锁垫 washer	2
41	01010-51020	螺栓 bolt	2
42	01602-21030	弹簧垫圈 washer, spring	2
43	154-30-11251	盖 cover	2
44	154-30-11262	垫 packing	2
45	01010-51230	螺栓 bolt	8
46	01602-21236	弹簧垫圈 washer, spring	8

第 403 图 台车架盖
 FIG. 403 TRACK FRAME COVER

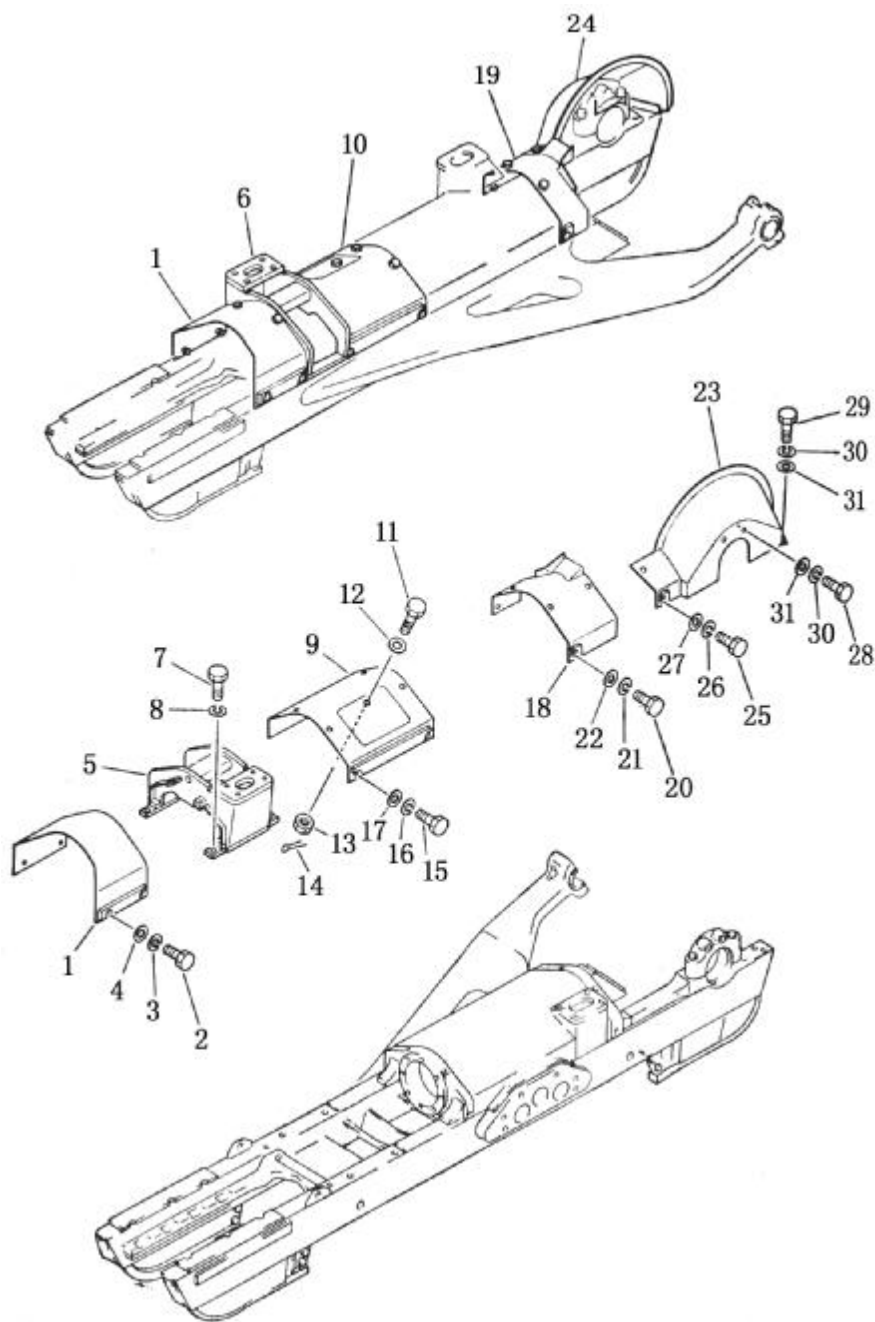

台车架盖
TRACK FRAME COVER

序号 Index No.	件号 Part No.	名称 Description	数量 Q' ty		
			SD22	SD22E SD22D	SD22S
403-1	154-30-11326	前盖 cover	2		
	23Y-40E-08000	前盖 cover		2	
	TS220. 30. 7	前盖 cover			2
2	01010-51225	螺栓 bolt	12	12	12
4	01643-31232	垫圈 washer	12	12	12
5	154-30-11274	支架 (左) support, L. H.	1	1	1
6	154-30-11284	支架 (右) support, R. H.	1	1	1
7	01011-52005	螺栓 bolt	8	8	8
8	01643-32060	垫圈 washer	8	8	8
9	154-30-12910	中罩组件 (左) cover, L. H.	1		
	23Y-40E-09000	中罩组件 (左) cover, L. H.		1	
	TS220. 20. 5	中罩组件 (左) cover, L. H.			1
10	154-30-12930	中罩组件 (右) cover, R. H.	1		
	23Y-40E-10000	中罩组件 (右) cover, R. H.		1	
	TS220、30、6	中罩组件 (右) cover, R. H.			1
11	154-30-27180	螺栓 bolt	2	2	2
12	01641-21223	垫圈 washer	2	2	2
13	01590-11215	螺帽 nut	2	2	2
14	04050-13025	开口销 pin, cotter	2	2	2
15	01010-51225	螺栓 bolt	16	16	16
17	01643-31232	垫圈 washer	16	16	16
18	154-30-11941	后罩 (左) cover, L. H.	1	1	1
19	154-30-11951	后罩 (右) cover, R. H.	1	1	1
20	01010-51230	螺栓 bolt	8	8	8
22	01643-31232	垫圈 washer	8	8	8
23	154-30-11383	驱动轮罩 (左) cover, L. H.	1	1	1
24	154-30-11393	驱动轮罩 (右) cover, L. H.	1	1	1
25	01010-51235	螺栓 bolt	4	4	4
27	01643-31232	垫圈 washer	4	4	4
28	01010-51635	螺栓 bolt	4	4	4
29	01010-51640	螺栓 bolt	4	4	4
31	01643-31645	垫圈 washer	8	8	8

第404图 履带滚轮护轨
FIG. 404 TRACK ROLLER GUARD

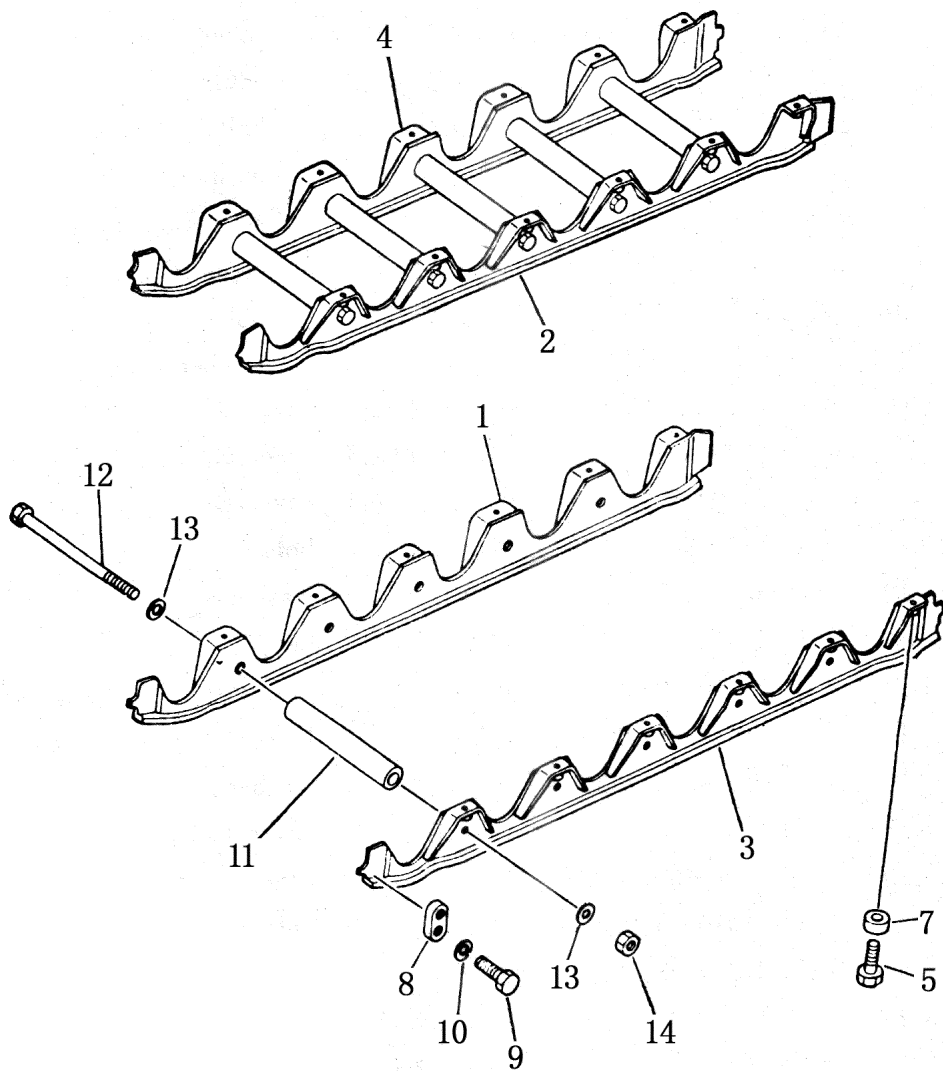

履带滚轮护轨
TRACK ROLLER GUARD

序号 No.	件 号 Part No.	名 称 Description	数量 Q' ty	
			SD22, SD22E SD22D	SD22S
404-1	154-30-11429	内护板 (左) guard, inner, L.H.	1	1
2	154-30-11419	内护板 (右) guard, inner, R.H.	1	1
3	154-30-11448	外护板 (左) guard, outer, L.H.	1	1
4	154-30-11438	外护板 (右) guard, outer, R.H.	1	1
5	01010-52265	螺栓 bolt	24	24
7	154-30-14130	衬垫 spacer	24	24
8	154-30-22190	挡板 retainer	6	6
9	01010-51840	螺栓 bolt	12	12
10	01602-21845	垫圈 washer	12	12
11	150-30-15553	管 tube	10	10
12	150-30-15563	螺栓 bolt	10	10
13	01643-32460	垫圈 washer	20	20
14	01580-12419	螺帽 nut	10	10
15	TS220. 30. 4	护板 guard		2
16	01010-52265	螺栓 bolt		8
17	01643-32260	加厚垫圈 washer		8
18	TS220. 30-1	导板 plate, lead		4
19	01010-52040	螺栓 bolt		16
20	01602-22060	垫圈 washer		16

第 405 图 引导轮
FIG. 405 IDLER

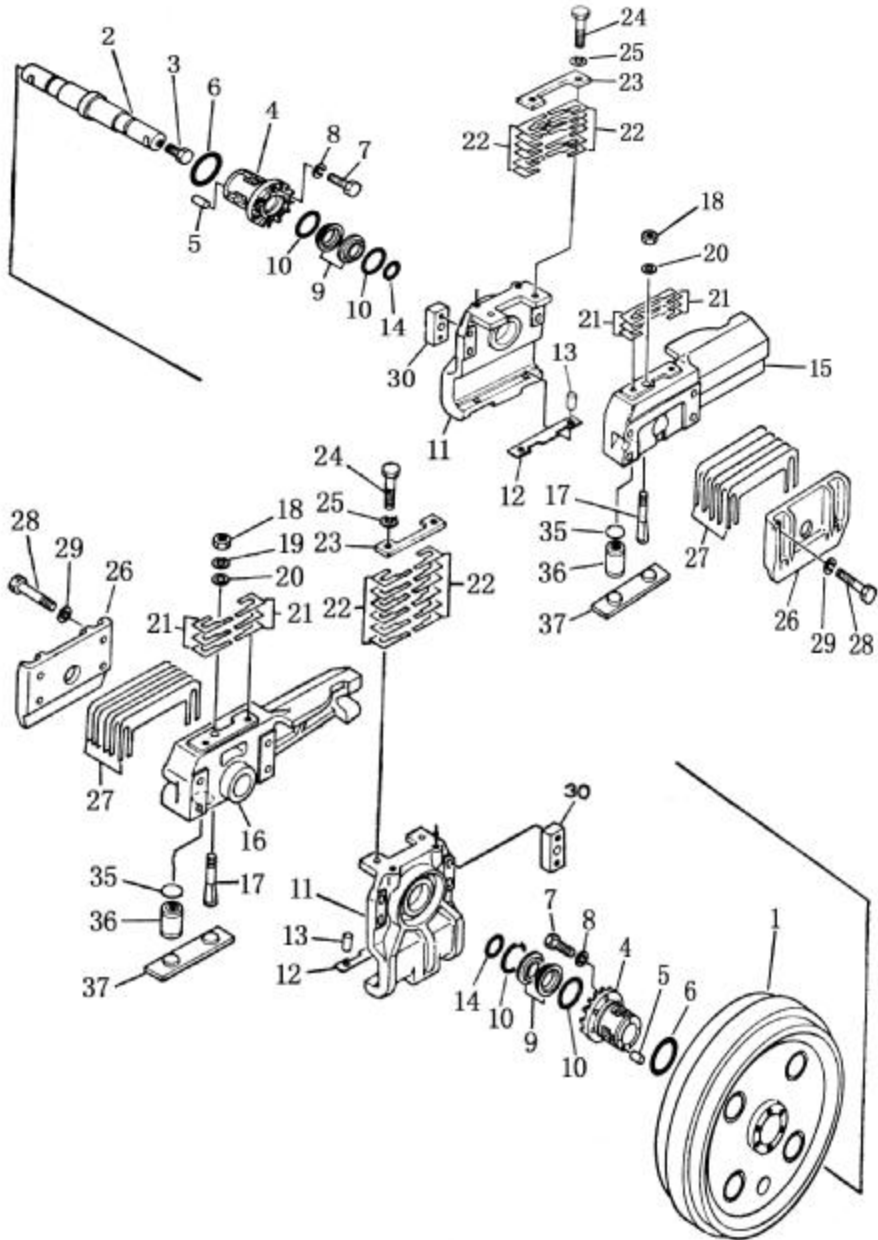

引导轮 IDLER

序号 Index No.	件 号 Part No.	名 称 Description	数量 Q' ty
	(154-30-00291)	引导轮总成 idler ass' y	2
405-1	150-30-22118	引导轮 idler, front	2
2	154-30-23122	引导轮轴 shaft	2
3	07052-21624	螺塞 plug	2
4	155-30-16201	轴套组件 bushing, ass' y	4
5	170-30-91130	定位销 pin, dowel	8
6	07000-02110	O型圈 O-ring	4
7	01010-51235	螺栓 bolt	24
8	01602-21236	弹簧垫圈 washer, spring	24
9	154-30-12271	浮封环 seal ring	8
10	150-30-12220	O型圈 O-ring	8
11	154-30-12641	导向板 guide	4
12	154-30-11963	减磨板 plate	4
13	04022-12025	销 pin, dowel	8
14	07000-02060	O型圈 O-ring	4
15	154-30-12611	支架(左) support, L. H	2
16	154-30-12621	支架(右) support, R. H	2
17	154-30-12650	定位销 pin, dowel	4
18	175-30-23180	螺母 nut	4
20	01643-31645	垫圈 washer	4
21	154-30-05040	填片总成 shim ass' y	4
22	154-30-05050	填片总成 shim ass' y	4
23	154-30-12670	压板 plate	4
24	154-30-12660	螺钉 screw	8
25	01602-21648	垫圈 washer, spring	8
26	154-30-11683	侧板 plate	4
27	154-30-05060	填片总成 shim ass' y	4
28	01011-52055	螺栓 bolt	16
29	01602-22060	垫圈 washer, spring	16
30	154-30-12730	座 seat	8
35	195-30-17960	垫板 plate	8
36	155-30-13230	橡胶弹簧 spring	8
37	175-30-24131	导板柳合件 guide plate	4

第 406 图 支 重 轮
FIG. 406 TRACK ROLLER

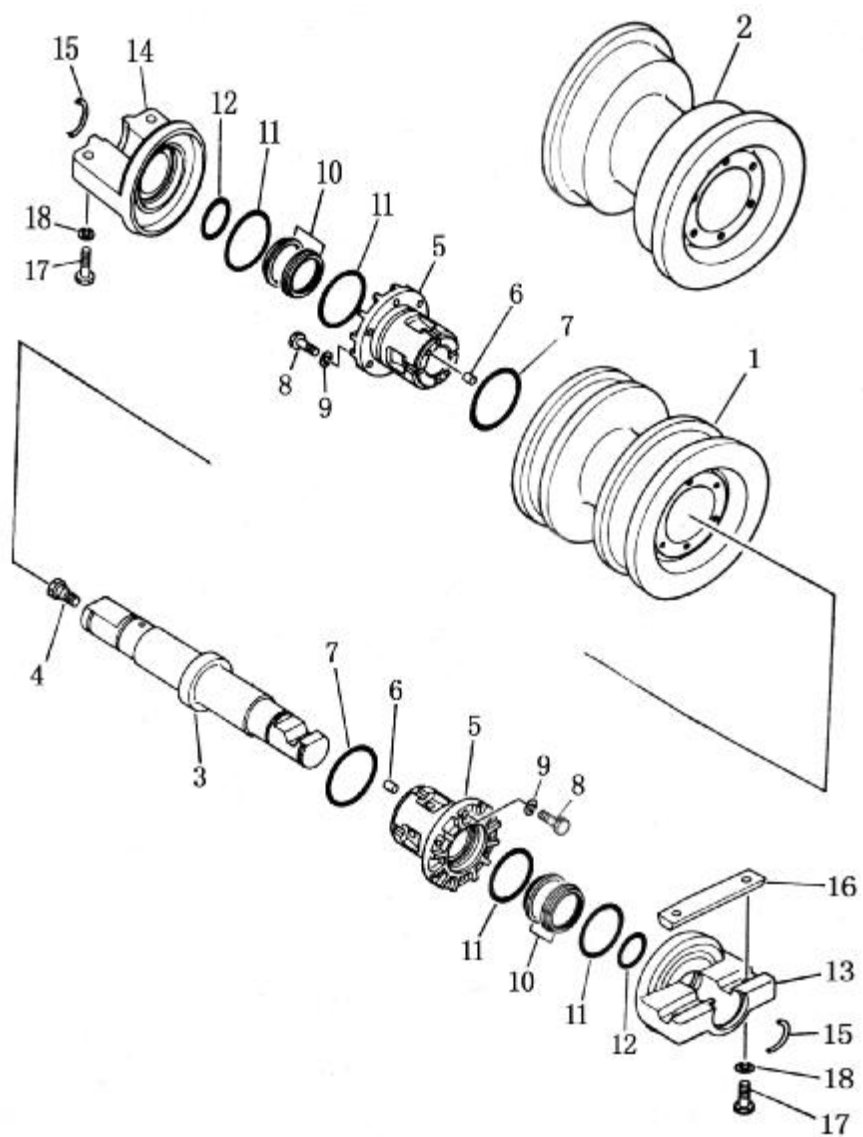

支重轮 TRACK ROLLER

序号 No.	件号 Part No.	名称 Description	数量 Q' ty		
			SD22	SD22E SD22D	SD22S
	155-30-00114	双边支重轮总成 track roller ass' y, double flange	4	6	6
	155-30-00124	单边支重轮总成 track roller ass' y, single flange	8	8	10
406-1	150-30-25125	双边支重轮 track roller, double flange	4	6	6
2	150-30-25115	单边支重轮 track roller, single flange	8	8	10
3	154-30-26131	支重轮轴 shaft	12	14	16
4	07052-21624	螺塞 plug	12	14	16
5	155-30-16201	轴套组件 bushing, ass' y	24	28	32
6	170-30-91130	销 pin	48	56	64
7	07000-02110	O型圈 O-ring	24	28	32
8	01010-51235	螺栓 bolt	144	168	192
9	01602-21236	弹簧垫圈 washer, spring	144	168	192
10	154-30-12271	密封环 seal ring	48	56	64
11	150-30-12220	O型圈 O-ring	48	56	64
12	07000-02060	O型圈 O-ring	24	28	32
13	154-30-26182	内盖 collar, inner	12	14	16
14	154-30-26192	外盖 collar, outer	12	14	16
15	154-30-26140	挡销 pin	24	28	32
16	155-30-16210	键 key	12	14	16
17	01010-62275	螺栓 bolt	48	56	64
18	01643-32260	弹簧垫圈 washer, spring	48	56	64

第 407 图 托 轮
FIG. 407 CARRIER ROLLER

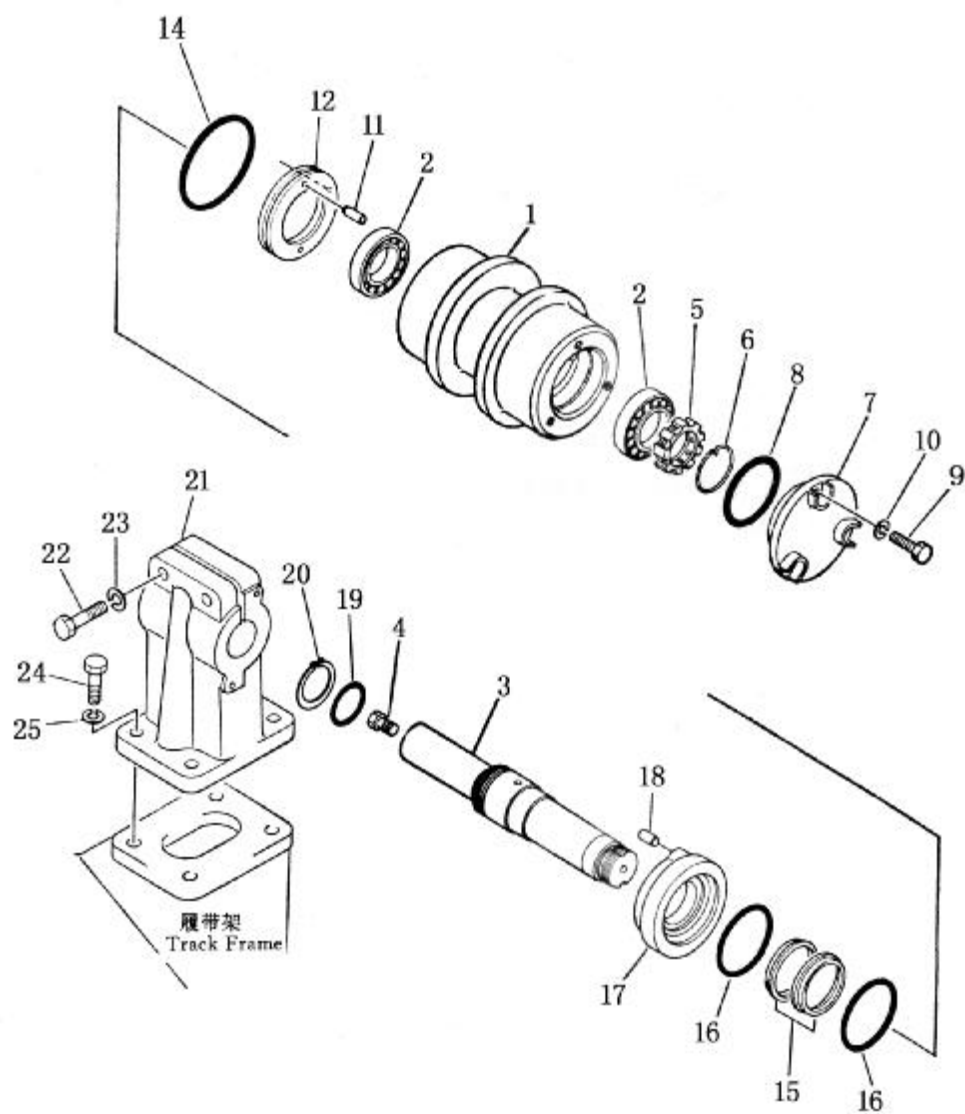

托 轮
CARRIER ROLLER

序号 No.	件 号 Part No.	名 称 Description	数量 Q' ty
407-1	154-30-25111	托轮 roller, carrier	4
2	06000-30211	滚柱轴承 bearing , roller	8
3	150-30-14311	托轮轴 shaft	4
4	07052-21624	螺塞 plug	4
5	150-30-14420	锁帽 nut	4
6	150-30-14430	卡环 ring, snap	4
7	154-30-25121	托轮盖 cover	4
8	07000-02105	O 型圈 O-ring	4
9	01010-51230	螺栓 bolt	12
10	01602-21236	弹簧垫圈 washer, spring	12
11	04020-00616	定位销 pin, dowel	8
12	154-30-25220	浮封座 seal	4
14	07000-02125	O 型圈 O-ring	4
15	154-30-12271	浮封环 floating, seal	8
16	150-30-12220	O 型圈总成 (由 2 O 型圈组成) O-ring ass'y (consists of 2 O-ring)	8
17	154-30-25230	浮封座 seal	4
18	155-30-15150	销 pin, dowel	8
19	07000-03062	O 型圈 O-ring	4
20	150-30-14320	挡圈 ring, snap	4
21	154-30-11292	托轮支架 bracket	4
22	01010-52080	螺栓 bolt	8
23	01602-22060	垫圈 washer, spring	8
24	01010-52060	螺栓 bolt	16
25	01602-22060	垫圈 washer, spring	16

第 408 图 履带（标准型）
FIG. 408 TRACK SHOE (STD)

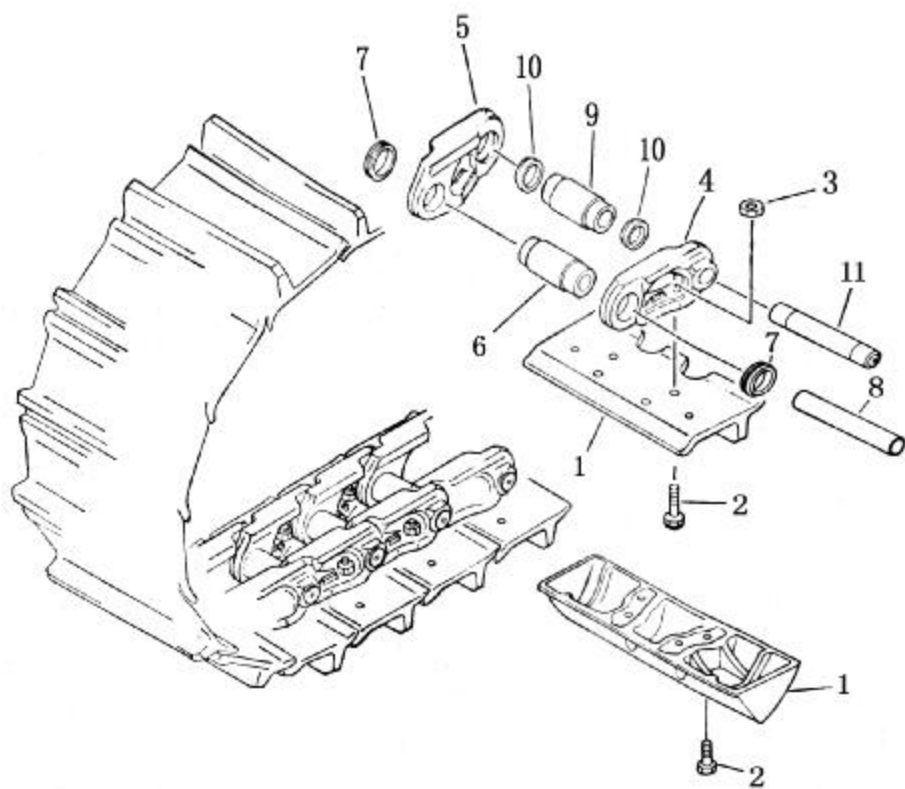

履 带 (标准型)
TRACK SHOE (STD)

序号 Index No.	件 号 Part No.	名 称 Description	数量 Q' ty		
			SD22	SD22E	SD22S
408-1	154-32-11006	履带总成 track shoe ass' y	1	1	1
	154-32-11113	履带板 shoe, track	76	82	
	TS220、32A-2	履带板 shoe, track			90
2	154-32-11230	履带螺栓 bolt, shoe	304	328	
	TS220、32A-1	履带螺栓 bolt, shoe			360
3	01803-02026	履带螺帽 nut, shoe	304	328	360
4	154-32-11127	链轨节(左) link, track, L.H	76	82	90
5	154-32-11137	链轨节(右) link, track, R.H	76	82	90
6	154-32-31140	销套 bushing, regular	72	82	86
7	154-32-11283	防尘密封圈 seal, dust, regular w-type	144	156	172
8	154-32-11152	履带销 pin, regular	72	78	86
9	154-32-31170	主销套 bushing, master	4	4	4
10	154-32-11260	防尘密封圈 seal, dust, master e-type	8	8	8
11	154-32-11193	履带主销 pin, master	4	4	4

第 409 图 履带 (润滑型)
FIG. 409 TRACK SHOE (LUBRICATE TYPE)

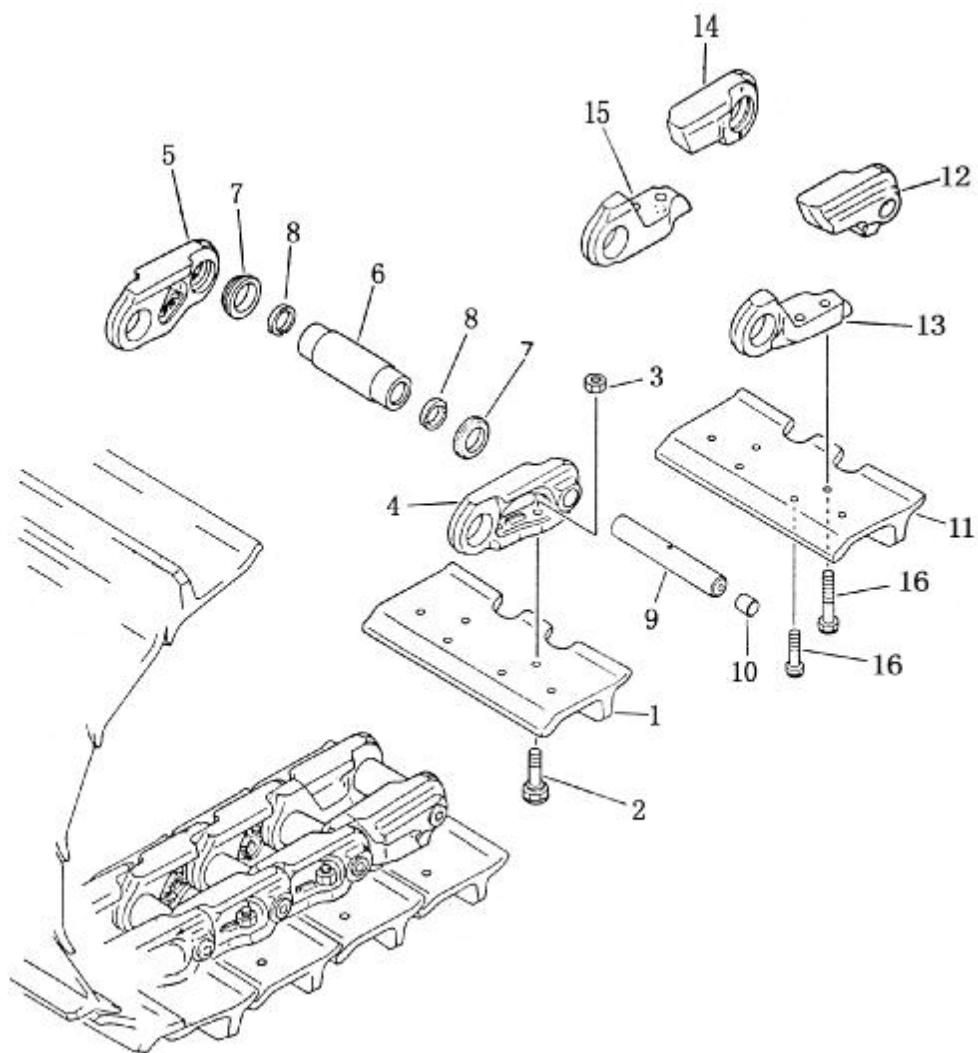

履带（润滑型）
TRACK SHOE (LUBRICATE TYPE)

序号 Index No.	件号 Part No.	名称 Description	数量 Q' ty
			SD22D
409-1	22M-42-00002	履带板 track shoe	80
2	7H3598	履带螺栓 bolt, shoe	320
3	1S1860	履带螺母 nut, shoe	320
4	8S2590	链轨节(左) link, track, L.H	80
5	8S2589	链轨节(右) link, track, R.H	80
6	3P621	销套 bushing, regular	82
7	8P2684	密封组件 seal	164
8	3P623	止推环 ring	164
9	3P622	履带销 pin, regular	82
10	6Y0454	挡块组件 stopper	82
11	22M-42-00001	主履带板 shoe, track, master	2
12	2P9654	主链轨节（销端，左） link, master (pin side, L.H.)	2
13	2P9656	主链轨节（套端，左） link, master (bushing, side, L.H.)	2
14	2P9653	主链轨节（销端，右） link, master (pin side, R.H.)	2
15	2P9655	主链轨节（套端，右） link, master (bushing, side, R.H.)	2
16	2P9670	主链轨节螺栓 bolt, link, master	8

护 罩
G U A R D

第 501 图 散热器护架
FIG. 501 RADIATOR GUARD

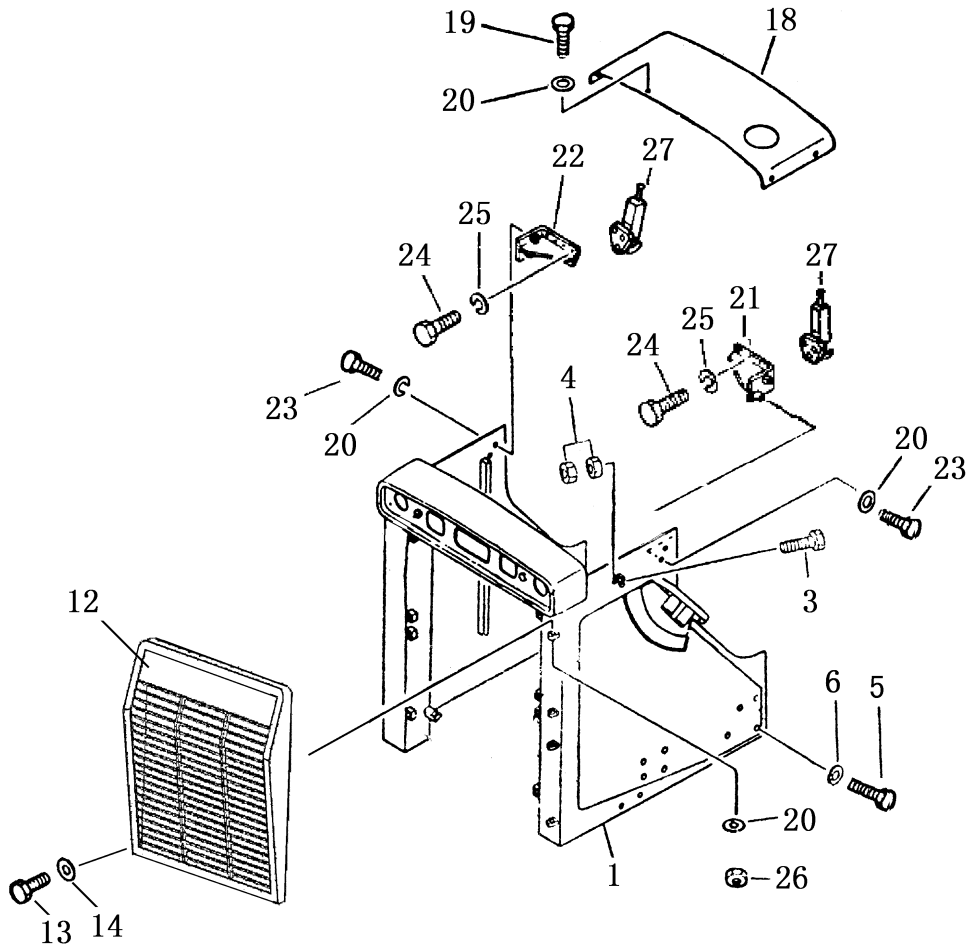

散热器护架
RADIATOR GUARD

序号 Index No.	件号 Part No.	名称 Description	数量 Q' ty	
			SD22, SD22E SD22D	SD22S
501-1	23Y-50B-04000	前罩 guard, radiator	1	
	158-50-01000	前罩 guard, radiator		1
3	01010-50835	螺栓 M8×35 bolt	2	2
4	01580-10806	螺母 M8 nut	4	4
5	01011-82745	螺栓 M27×3×145 bolt	16	16
6	01643-32780	平垫 27 washer	16	16
12	23Y-50B-07000	护栅 grill	1	1
13	01010-51640	螺栓 M16×40 bolt	8	4
14	01643-31648	平垫 16 washer	8	4
18	23Y-50B-05000	盖 cover	1	
	158-50-02000	盖 cover		1
19	01010-51225	螺栓 M12×25 bolt	4	4
20	01643-31232	平垫 12 washer	12	12
21	154-54-22891	左支架 bracket L.H	1	1
22	154-54-22911	右支架 bracket R.H.	1	1
23	01010-51255	螺栓 M12×55 bolt	4	4
24	01010-51020	螺栓 M10×20 bolt	6	6
25	01643-31032	平垫 10 washer	6	6
26	01580-81210	螺母 M10 nut	2	2
27	175-54-21361	锁钩组件 lock ass' y	1	1

第 502 图 发动机罩
 FIG. 502 ENGINE HOOD

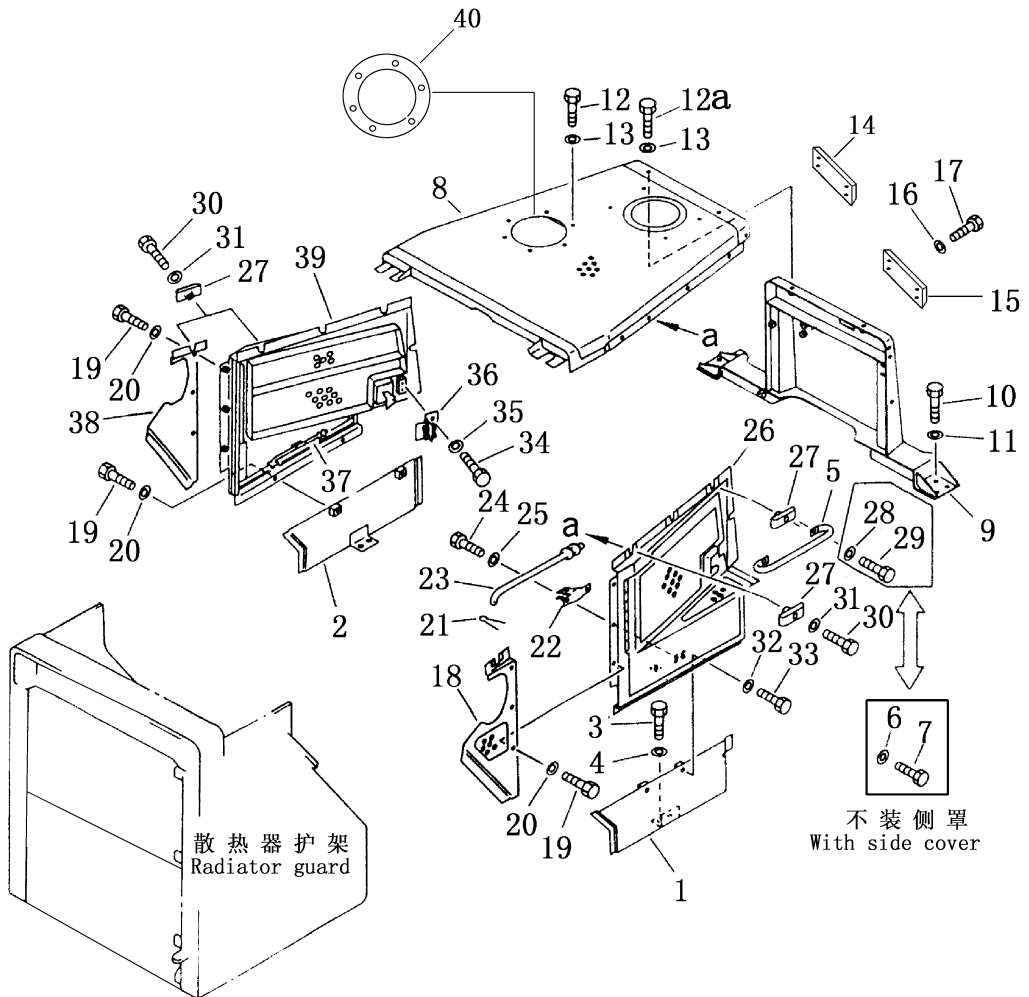

发动机罩
ENGINE HOOD

序号 Index No.	件号 Part No.	名称 Description	数量 Q'ty	
			SD22, SD22E SD22D	SD22S
502-1	23Y-50B-02000	左侧盖 cover L.H	1	
	158-54-03000	左侧盖 cover L.H		1
2	23Y-50B-03000	右侧盖 cover R.H	1	
	158-54-04000	右侧盖 cover R.H		1
3	01010-51235	螺栓 bolt	4	4
4	01643-31232	平垫 washer	4	4
5	09420-01903	扶手 handle	2	2
6	01643-31232	平垫 washer	4	4
7	01010-51235	螺栓 bolt	4	4
8	23Y-50B-01000	上罩 hood upper	1	1
9	23Y-50B-06000	支架 bracket	1	1
10	01010-51635	螺栓 bolt	8	8
11	01643-31645	平垫 washer	8	8
12	01010-51245	螺栓 bolt	10	10
13	01643-31232	平垫 washer	10	10
14	23Y-50B-00001	板 plate	1	1
15	23Y-50B-00002	板 plate	1	1
16	01643-31232	平垫 washer	8	8
17	01010-51230	螺栓 bolt	8	8
18	23Y-54B-01000	左前罩 plate L.H	1	
	158-54-01000	左护罩 cover, L.H		1
19	01010-51225	螺栓 bolt	6	6
20	01643-31232	平垫 washer	6	6
21	04050-12016	开口销 pin, cotter	2	2
22	198-54-19150	卡簧 spring	2	2
23	154-54-43240	杆(左) bar, L.H	1	1
24	01010-50612	螺栓 bolt	4	4
25	01643-30623	垫圈 washer	4	4
26	23Y-54B-02000	左护罩 cover, L.H	1	
27	09462-00080	定位器 locator	10	10

发动机罩
ENGINE HOOD

序号 Index No.	件号 Part No.	名称 Description	数量 Q'ty	
			SD22, SD22E SD22D	SD22S
502-28	01643-31232	垫圈 washer	4	4
29	01010-51260	螺栓 bolt	4	4
30	01010-51250	螺栓 bolt	6	6
31	01643-31232	垫圈 washer	6	6
32	01643-31232	垫圈 washer	4	4
33	01010-51225	螺栓 bolt	4	4
34	01010-51020	螺栓 bolt	4	4
35	01643-31032	垫圈 washer	4	4
36	195-54-42300	托架 bracket	2	2
37	154-54-43250	杆(右) bar ,R.H	1	1
38	23Y-54B-03000	右前罩 plate ,R.H	1	
	158-54-02000	右前罩 cover ,R.H		1
39	23Y-54B-04000	右护罩 cover ,R.H	1	1
40	154-54-14610	压盘 plate	1	1

第 503 图 翼板
 FIG. 503 FENDER

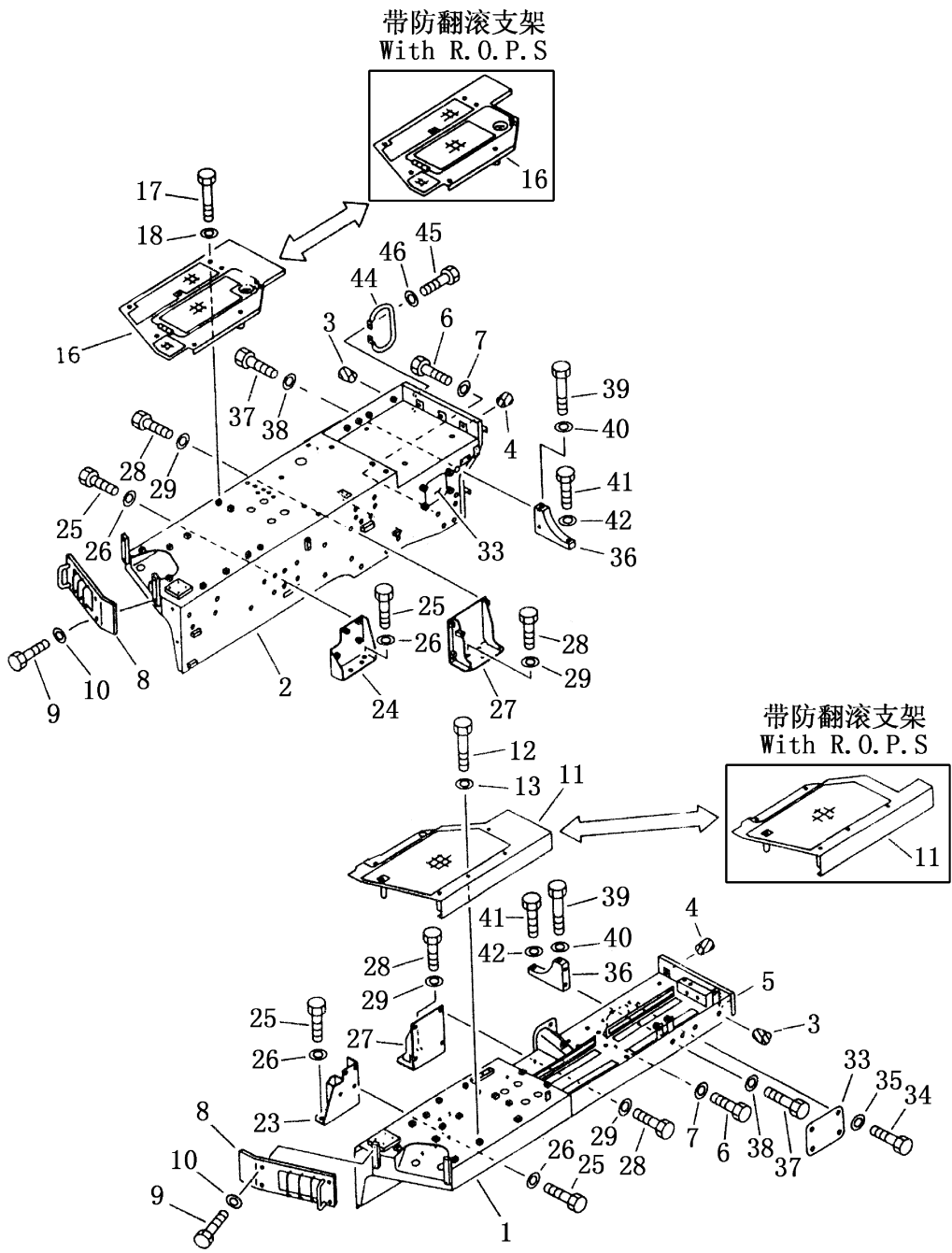

翼 板 FENDER

序号 Index No.	件 号 Part No.	名 称 Description	数量 Q' ty	
			SD22, SD22E SD22D	SD22S
503-1	23Y-51B-07000	翼板 (左) fender L.H	1	1
2	23Y-51B-06000	翼板 (右) fender R.H	1	
	158-51-01000	翼板 (右) fender R.H		1
3	07049-01620	软木塞 plug	8	8
4	07049-02430	软木塞 plug	6	6
5	07049-01822	软木塞 plug	4	4
6	01010-52050	螺栓 m20×50 bolt	14	14
7	01643-32060	垫圈 washer	14	14
8	23Y-51B-10000	盖板 cover	2	2
9	01010-51230	螺栓 bolt	8	8
10	01643-31232	垫片 washer	8	8
11	23Y-51B-09000	盖板 (左) (不装防翻支架) cover L.H (without rops)	1	1
	23Y-51B-16000	盖板 (左) (装防翻支架) cover L.H (with rops)	1	1
12	01011-51210	螺栓 M12×10 bolt	6	6
13	01643-31232	垫圈 washer	6	6
16	23Y-51B-01000	盖板 (右) (不装防翻支架) cover R.H (without rops)	1	1
	23Y-51B-15000	盖板 (右) (装防翻支架) cover R.H (with rops)	1	1
17	01011-51210	螺栓 M12×10 bolt	6	6
18	01643-31232	垫圈 washer	6	6
23	154-54-41860	支架 (左) bracket l.h.	1	1
24	154-54-11776	支架 (右) bracket r.h.	1	1
25	01010-51640	螺栓 M16×40 bolt	16	16
26	01643-31645	垫圈 washer	16	16
27	154-54-11757	支架 bracket	2	2

翼板 FENDER

序号 Index No.	件号 Part No.	名称 Description	数量 Q' ty	
			SD22, SD22E SD22D	SD22S
503—28	01010-51640	螺栓 M16×40 bolt	14	14
29	01643-31645	垫圈 washer	14	14
30	154-54-41931	盖 cover	1	1
31	01010-51230	螺栓 M12×30 bolt	4	4
32	01643-31232	垫圈 washer	4	4
33	154-54-12380	盖 cover	2	2
34	01010-51235	螺栓 M12×35 bolt	8	8
35	01643-31232	垫圈 washer	8	8
36	154-54-11970	支架 bracket	2	2
37	01010-51635	螺栓 M16×35 bolt	4	4
38	01643-31645	垫圈 washer	4	4
39	01011-51690	螺栓 M16×90 bolt	2	2
40	01643-31645	垫圈 washer	2	2
41	01010-51655	螺栓 M16×55 bolt	2	2
42	01643-31645	垫圈 washer	2	2
44	154-54-22990	把手 handle	1	1
45	01010-51850	螺栓 M18×50 bolt	2	2
46	01643-31845	垫圈 washer	2	2

第 504 图 支 撑
 FIG. 504 SUPPORT

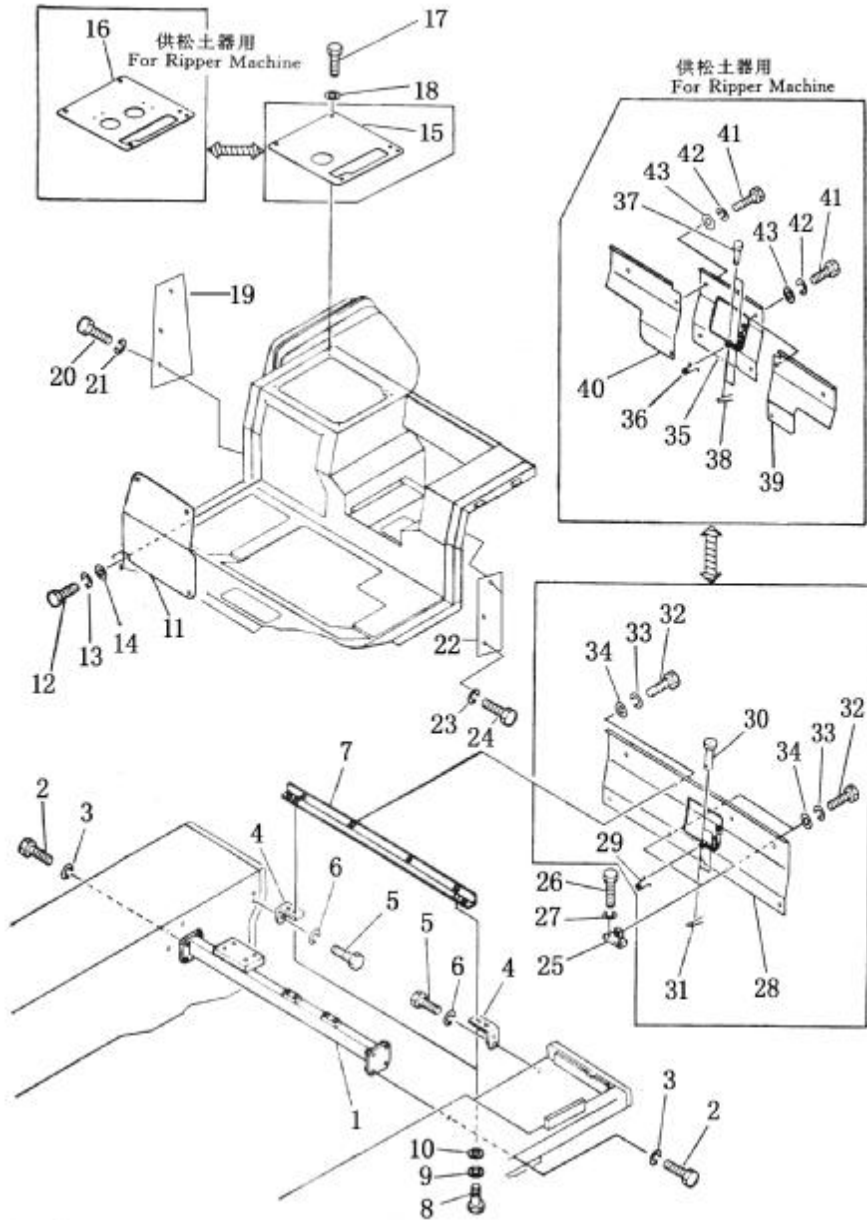

支 撑 SUPPORT

序号 Index No.	件 号 Part No.	名 称 Description	数量 Q' ty
504-1	23Y-51B-14000	支架 support	1
2	01010-51640	螺栓 bolt	8
3	01643-31645	加厚垫圈 washer	8
4	154-54-12694	托架 bracket	2
5	01010-51235	螺栓 bolt	4
6	01602-21236	垫圈 washer	4
7	154-54-11449	角钢 angle	1
8	01010-51230	螺栓 bolt	2
9	01602-21236	垫圈 washer	2
10	01643-31232	加厚垫圈 washer	2
11	23Y-51B-22000	盖 cover	1
12	01010-50825	螺栓 bolt	4
13	01643-30823	垫圈 washer	4
14	01602-20825	加厚垫圈 washer	4
15	23Y-51B-17000	盖 cover	1
16	23Y-51B-03000	盖（供松土器用） cover, for ripper	1
17	01010-50825	螺栓 bolt	4
18	01643-30823	加厚垫圈 washer	4
19	23Y-51B-00009	板 plate	1
20	01010-51230	螺栓 bolt	3
21	01643-31232	加厚垫圈 washer	3
22	23Y-51B-00007	板 plate	1
23	01010-51230	螺栓 bolt	3
24	01643-31232	加厚垫圈 washer	3
25	154-54-12791	托架 bracket	2
26	01010-51225	螺栓 bolt	4
27	01602-21236	垫圈 washer	4
28	23Y-51-02000	盖 cover	1
29	09463-00006	弹簧 spring	1
30	04205-10618	销轴 pin	1
31	04050-11610	开口销 pin, cotter	2
32	01010-51230	螺栓 bolt	8
33	01602-21236	垫圈 washer	8
34	01643-31232	加厚垫圈 washer	8

支 撑
SUPPORT

序号 Index No.	件 号 Part No.	名 称 Description	数 量 Q' ty
		以下配件供松土器用 The following parts are used for ripper	
504-35	23Y-51-01000	盖 cover	1
36	09463-00006	弹簧 spring	1
37	04205-10618	销轴 pin	2
38	04050-11610	开口销 pin, cotter	2
39	154-54-14640	盖（左） cover, L.H.	1
40	154-54-14650	盖（右） cover, R.H.	1
41	01010-51230	螺栓 bolt	6
42	01602-21236	垫圈 washer	6
43	01643-31232	加厚垫圈 washer	6

第 505 图 地板架
FIG. 505 FLOOR FRAME

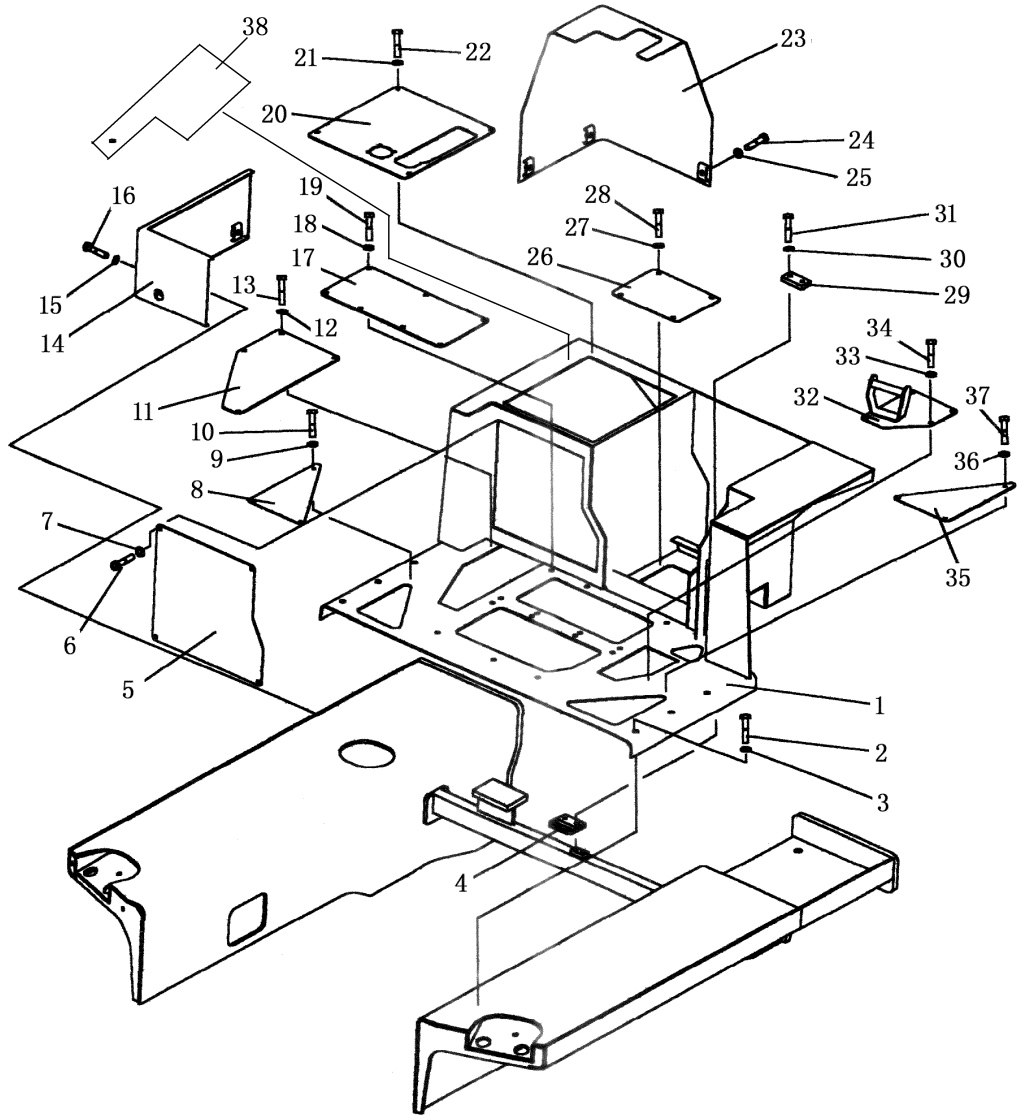

地 板 架
FLOOR FRAME

序号 Index No.	件 号 Part No.	名 称 Description	数量 Q' ty
505-1	23Y-51B-02000	地板架 frame floor (without cab)	1
2	01010-51490	螺栓 M14×50 bolt	6
3	01643-31445	垫圈 washer	6
4	154-54-22441	座	1
5	23Y-51B-22000	盖板 cover	1
6	01010-50825	螺栓 bolt	4
7	01643-30823	垫圈 washer	4
8	23Y-51B-00002	盖板 cover	1
9	01643-31232	垫圈 washer	3
10	01010-51230	螺栓 bolt	3
11	23Y-51B-20000	盖板 cover	1
12	01643-31232	垫圈 washer	4
13	01010-51230	螺栓 bolt	4
14	23Y-51B-04000	盖板 cover	1
15	01643-31232	垫圈 washer	3
16	01010-51230	螺栓 bolt	3
17	23Y-51B-21000	盖板 cover	1
18	01643-31232	垫圈 washer	7
19	01010-51230	螺栓 bolt	7
20	23Y-51B-03000	盖板 cover	1
21	01643-31232	垫圈 washer	4
22	01010-50825	螺栓 bolt	4
23	23Y-51B-05000	盖板(右)(松土器用) cover R.H, For Ripper	1
	23Y-51B-18000	盖板(右) cover R.H	1
24	01010-51230	螺栓 bolt	5
25	01643-31232	垫圈 washer	5
26	175-54-33231	盖板 cover	1
27	01643-31232	垫圈 washer	4
28	01010-51230	螺栓 bolt	4
29	195-54-23471	板 plate	1
30	01643-31445	垫圈 washer	4

地 板 架
FLOOR FRAME

序号 Index No.	件 号 Part No.	名 称 Description	数量 Q' ty
505-31	01010-51460	螺栓 bolt	4
32	17G-51A-26000	盖板 cover	1
33	01643-31232	垫圈 washer	4
34	01010-51230	螺栓 bolt	4
35	23Y-51B-00005	盖板 cover	1
36	01643-31232	垫圈 washer	3
37	01010-51230	螺栓 bolt	3
38	23Y-51B-00001	板 plate	1

第 506 图
FIG. 506

蓄电池罩
BATTERY COVER

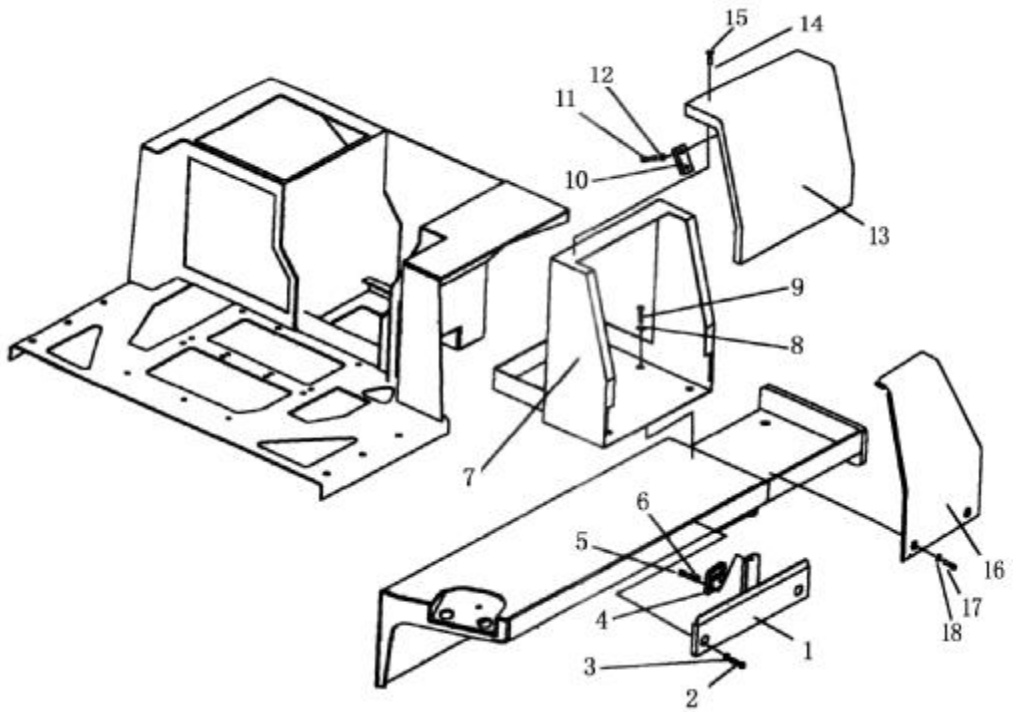

蓄电池罩
BATTERY COVER

序号 Index No.	件 号 Part No.	名 称 Description	数量 Q' ty
506-1	23Y-51B-12000	盖 cover	1
2	01010-51230	螺栓 bolt	2
3	01643-31232	垫圈 washer	2
4	154-54-46150	支架 bracket	1
5	01010-51230	螺栓 bolt	2
6	01643-31232	垫圈 washer	2
7	23Y-51B-13000	电瓶箱 battery box	1
8	195-57-11521	螺栓 bolt	4
9	01643-30623	垫圈 washer	2
10	198-54-19150	卡簧 spring	1
11	01010-50612	螺栓 bolt	2
12	01643-30623	垫圈 washer	2
13	23Y-51B-11000	电瓶罩 battery cover	1
14	01010-51230	螺栓 bolt	2
15	01643-31232	垫圈 washer	2
16	23Y-51B-08000	盖 cover	1
17	01010-51230	螺栓 bolt	2
18	01643-31232	垫圈 washer	2
19	198-54-41941	帽 cap	4

第 507 图 护 底
FIG. 507 BOTTOM GUARD

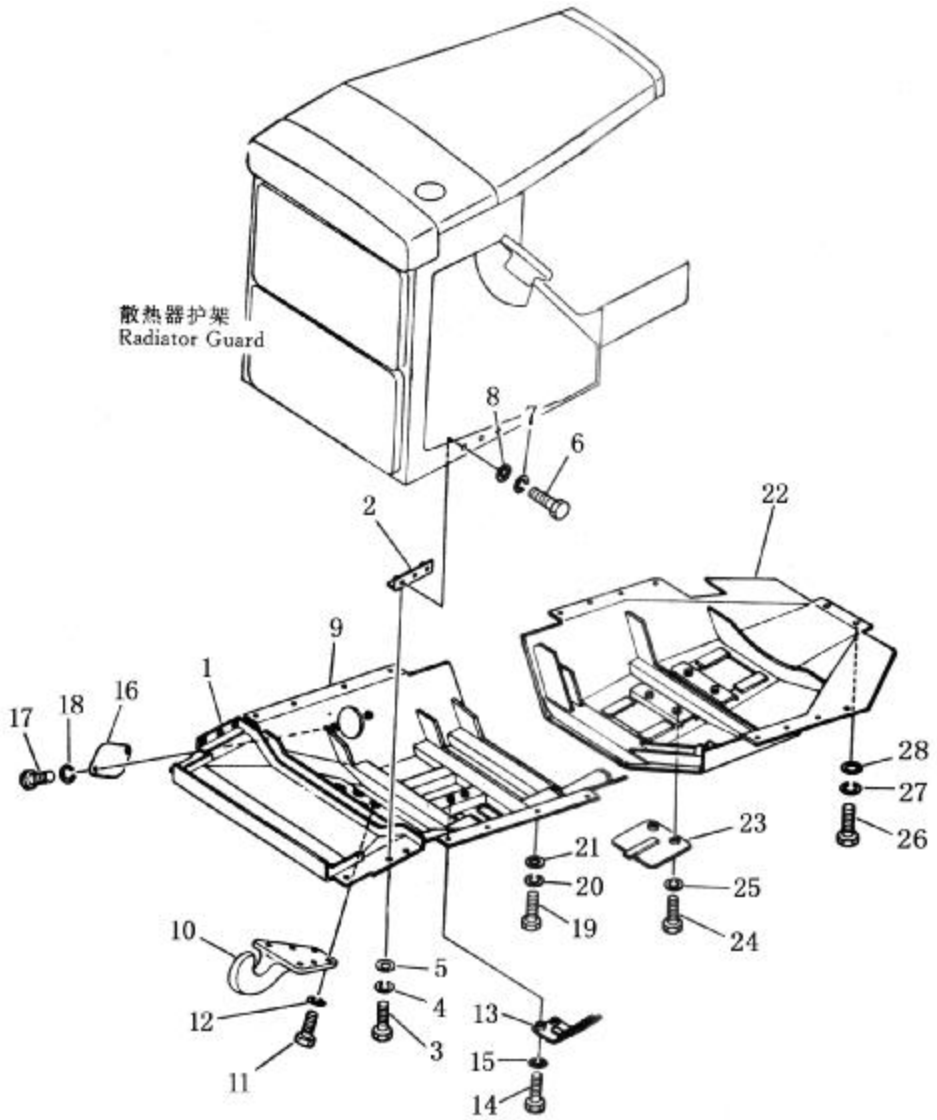

护 底 BOTTOM GUARD

序号 Index No.	件 号 Part No.	名 称 Description	数量 Q' ty	
			SD22, SD22E SD22D	SD22S
507-1	23Y-50B-08000	前盖 cover, front	1	
	TS220、54、8	前盖 cover, front		1
2	154-54-12570A	架 bracket	1	
3	01010-52050	螺栓 bolt	4	5
4	01602-22060	垫圈 washer	4	5
5	01643-32060	加厚垫圈 washer	4	5
6	01010-52050	螺栓 bolt	6	
7	01602-22060	垫圈 washer	6	
8	01643-32060	加厚垫圈 washer	6	
9	154-54-12117A	前底护板 cover	1	
	TS220、54、7	前底护板 cover		1
10	150-54-12180	钩 hook	1	
	TS220、54、7-1	钩 hook		1
11	01010-52070	螺栓 bolt	6	4
12	01602-22060	弹簧垫圈 washer, spring	6	4
13	154-54-12164A	盖 cover	1	
	TS220、54、7、2	盖 cover		1
14	01010-51230	螺栓 bolt	2	2
15	01602-21236	弹簧垫圈 washer, spring	2	2
16	154-54-12850	盖 cover	1	
	TS220、54、7-2	盖 cover		1
17	01010-51230	螺栓 bolt	2	2
18	01602-21236	弹簧垫圈 washer, spring	2	2
19	01010-52050	螺栓 bolt	8	6
20	01602-22060	弹簧垫圈 washer, spring	8	6
21	01643-32060	加厚垫圈 washer	8	6
22	154-54-12125	后底护板 cover, rear	1	
	TS220、54、3	后底护板 cover, rear		1
23	154-54-12182	盖 cover	2	
	TS220、54、3、2	盖 cover		2
24	01010-51230	螺栓 bolt	4	4
25	01602-21236	弹簧垫圈 washer, spring	4	4
26	01010-52050	螺栓 bolt	10	10
27	01602-22060	弹簧垫圈 washer, spring	10	10
28	01643-32060	加厚垫圈 washer	10	10

第 508 图 油缸支架
FIG. 508 CYLINDER STAY

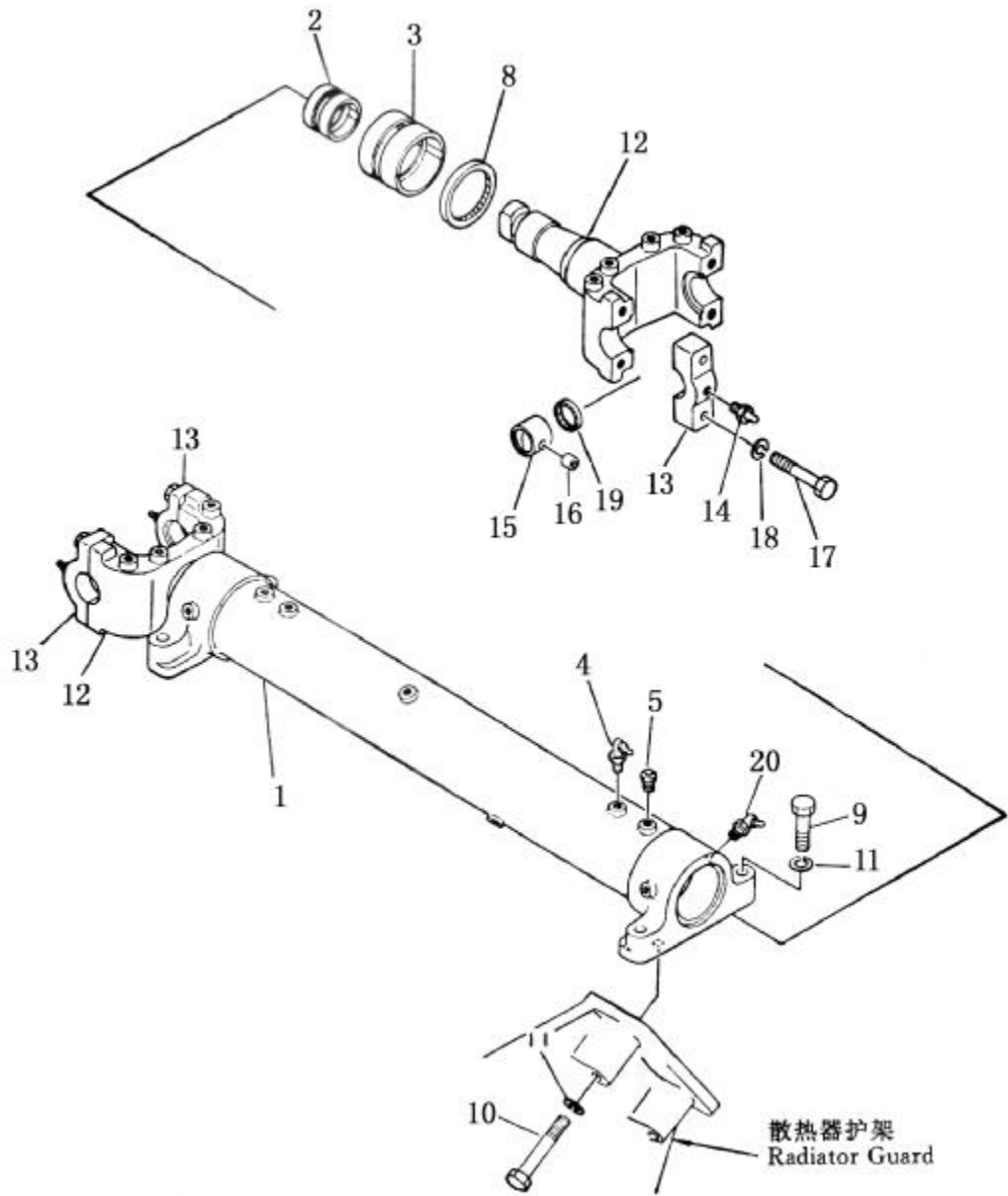

油缸支架
CYLINDER STAY

序号 Index No.	件号 Part No.	名称 Description	数量 Q' ty	
			SD22, SD22E SD22D	SD22S
508-1	154-61-13115	支架 cylinder stay ass' y	1	
2	154-61-13130	衬套 bushing	2	2
3	154-61-13141	衬套 bushing	2	2
4	07020-00900	接头式压注油杯 fitting, grease	2	
5	07042-00108	螺塞 plug	2	
8	154-61-13150	密封圈 seal, dust	2	2
9	01010-52295	螺栓 bolt	4	
10	01011-52245	螺栓 bolt	4	
11	01602-22268	弹簧垫圈 washer, spring	8	
12	154-61-13214	叉 yoke	2	2
13	154-61-13233	半瓦 cap	2	2
14	07020-00000	直通式压注油杯 fitting, grease	4	4
15	154-61-13246	衬套 bushing	4	4
16	170-70-15190	销 pin	4	4
17	01010-51885	螺栓 bolt	8	8
18	01602-21854	弹簧垫圈 washer, spring	8	8
19	07145-00075	防尘圈 seal, dust	4	4
20	07020-00900	油杯 fitting, grease		2

第 509 图 防 翻 滚 架
FIG. 509 ROLLOVER PROTECTIVE STRUCTURE

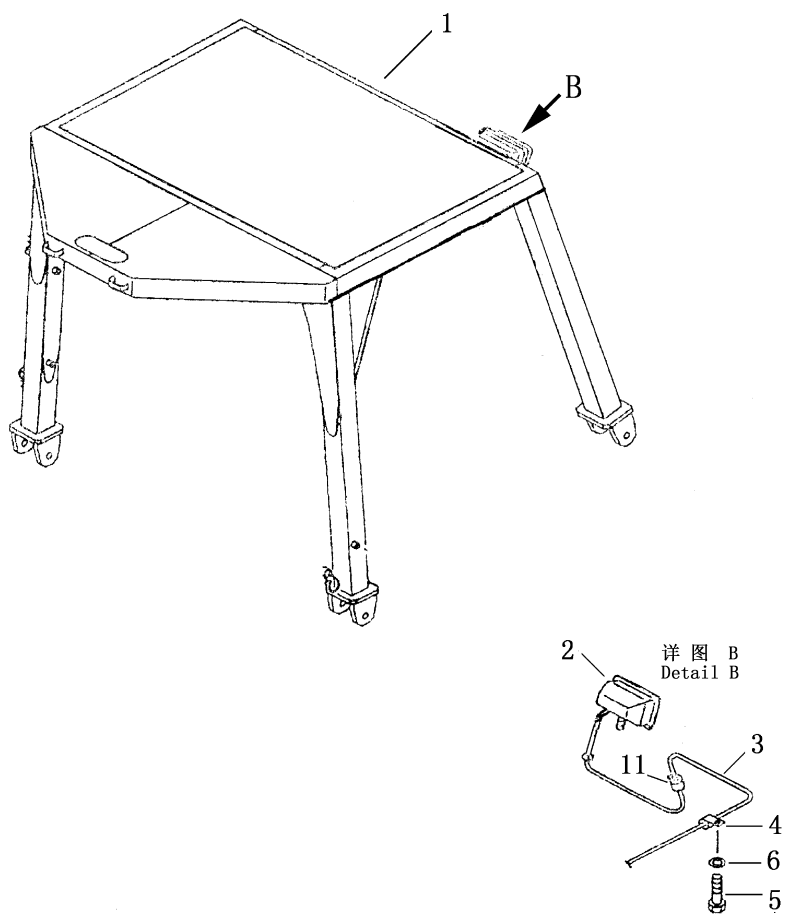

防 翻 滚 架
ROLL OVER PROTECTIVE STRUCTURE

序号 Index No.	件 号 Part No.	名 称 Description	数量 Q'ty
509-1	23Y-59C-01000	防翻滚架 guard	1
2	16Y-07C-09000	灯 lamp	1
3	23Y-07B-10000	线束 wire	1
4	08035-02510	线夹 clip	4
5	01010-51016	螺栓 M10×16 bolt	4
6	01643-31232	垫圈 washer	4

第 510 图 防 翻 滚 架 安 装
 FIG. 510 ROLLOVER PROTECTIVE STRUCTURE MOUNT

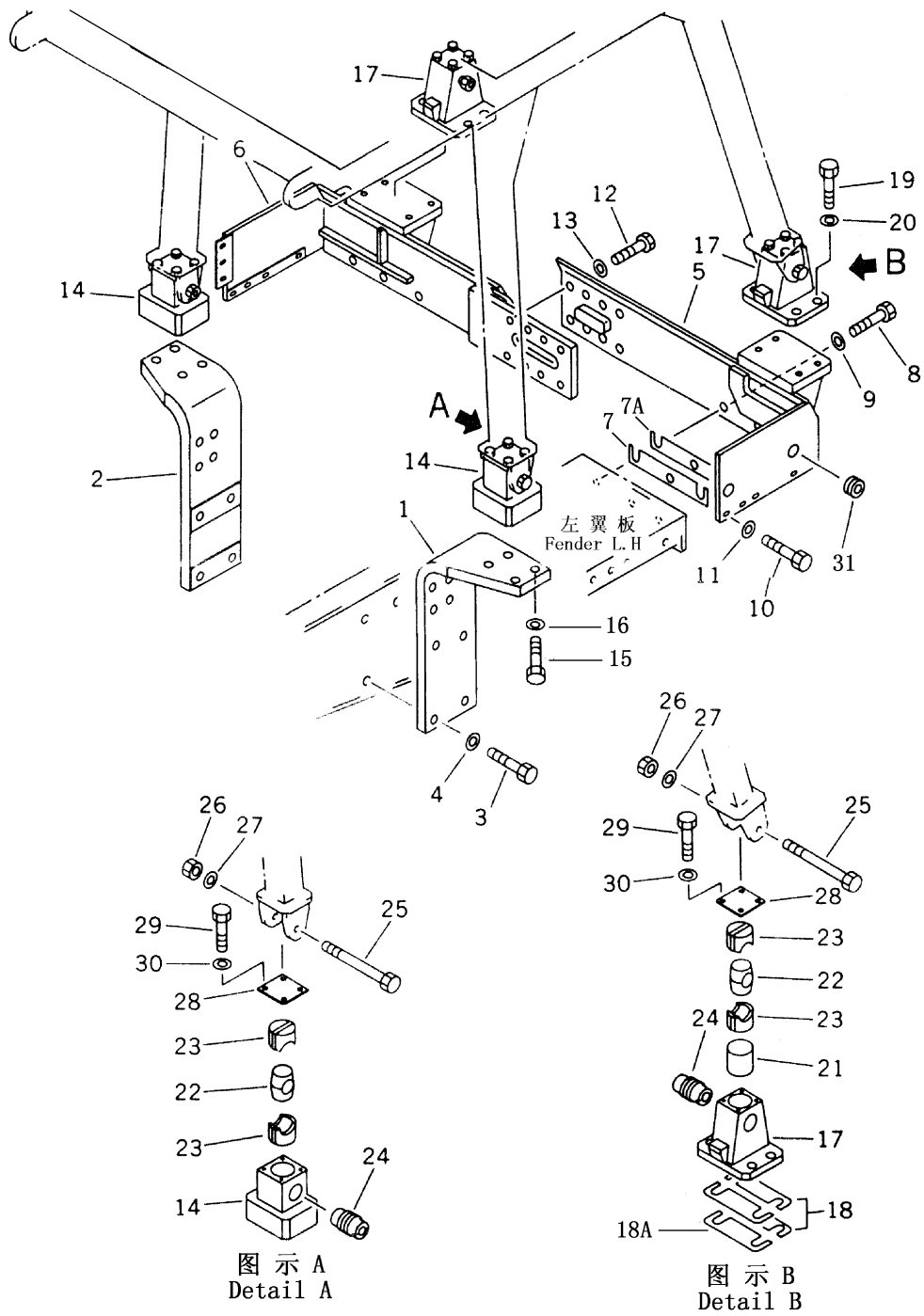

防 翻 滚 架 安 装
 ROLLOVER PROTECTIVE STRUCTURE MOUNT

序号 Index No.	件 号 Part No.	名 称 Description	数量 Q'ty
510-1	23Y-59C-04000	板 (左) plate l.h.	1
2	23Y-59C-05000	板 (右) plate r.h.	1
3	01010-82075	螺栓 bolt	12
4	01643-32060	垫圈 washer	12
5	23Y-59C-02000	支架 (左) bracket l.h.	1
6	23Y-59C-03000	支架 (右) bracket r.h.	1
8	01010-82465	螺栓 bolt	6
9	01643-32460	垫圈 washer	6
10	01010-81655	螺栓 bolt	6
11	21T-54-16150	垫圈 washer	6
12	01010-82465	螺栓 bolt	6
13	01643-32460	垫圈 washer	6
14	154-978-3151	支架 bracket	2
15	01011-83010	螺栓 bolt	8
16	01643-33080	垫圈 washer	8
17	23Y-57-17000	支架 bracket	2
19	23Y-57-00044	螺栓 bolt	8
20	01643-32460	垫圈 washer	8
21	154-978-3171	座 seat	2
22	195-54-45490	块 black	2
23	154-54-42220	橡胶 rubber	4
24	195-54-45510	环 collar	2
25	175-978-5210	螺栓 bolt	4
26	01580-12722	螺母 nut	4
27	01643-32780	垫圈 washer	4
28	195-56-11320	板 plate	2
29	01010-51230	螺栓 bolt	16
30	01643-31232	垫圈 washer	16
31	23Y-57-00038	螺栓 bolt	2
32	23Y-57-00045	支撑块 block	2
33	23Y-57-00037	缓冲垫 washer	2
34	23Y-57-00041	座 pedestal	2

第 511 图 平衡梁
 FIG. 511 EQUALIZER BAR

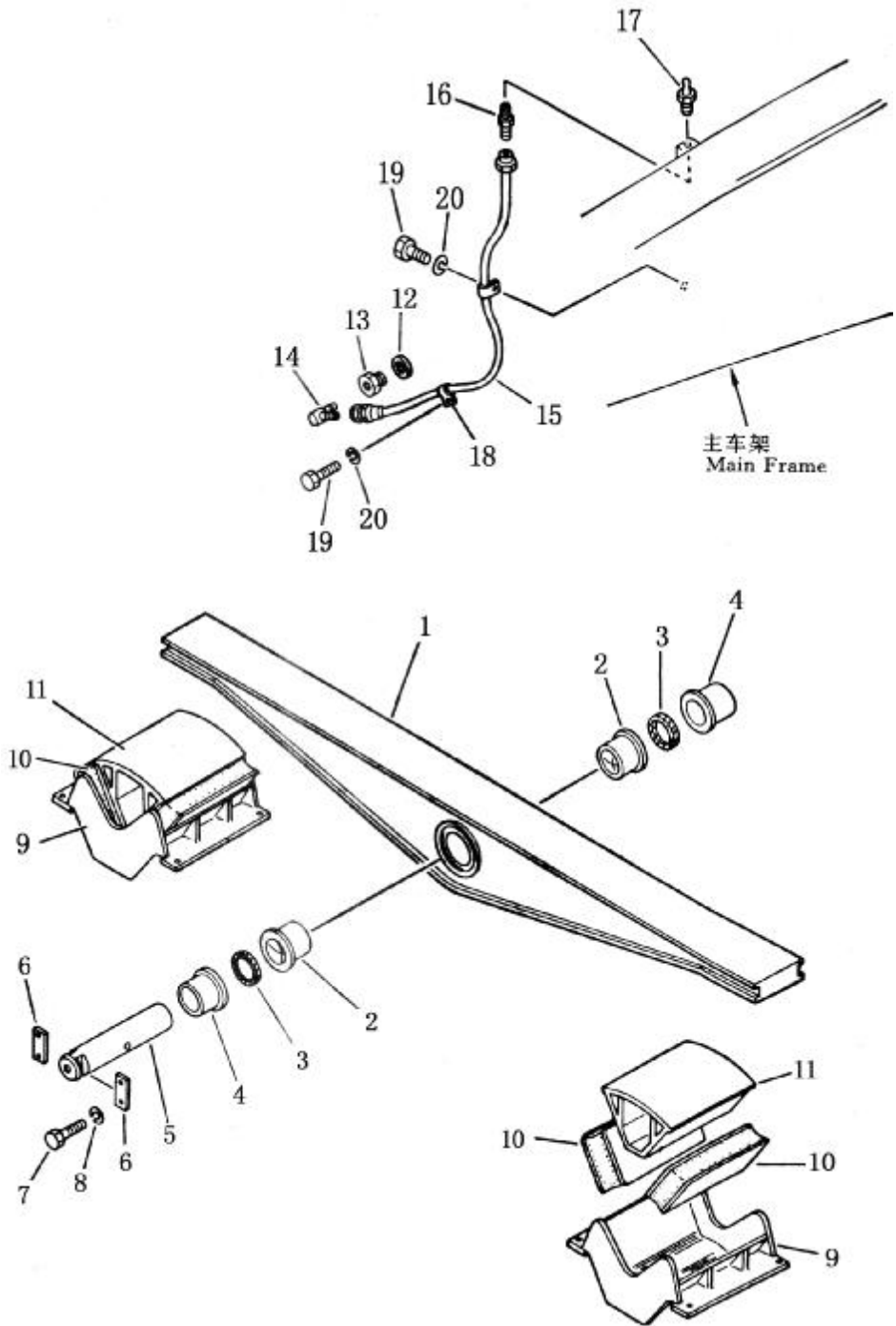

平衡梁
EQUALIZER BAR

序号 No.	件 号 Part No.	名 称 Description	数量 Q' ty	
			SD22, SD22E SD22D	SD22S
511-1	154-50-11115	平衡梁合件 equalizer, bar ass' y	1	
	TS220、50、1	平衡梁合件 equalizer, bar ass' y		1
2	154-50-11164	衬套 bushing	2	2
3	154-50-11250	防尘圈 seal, dust	2	2
4	154-50-11171	衬套 bushing	2	2
5	154-50-11135	中心销 pin, center	1	1
6	04082-00616	轴端止动垫片 lock, plate	2	2
7	01010-51640	螺栓 bolt	4	4
8	01602-21648	弹簧垫圈 washer, spring	4	4
9	154-50-11152	支架 support	2	2
10	154-50-11193	缓冲垫 pad, rubber	4	4
11	154-50-11123	垫座 seat	2	2
14	07217-50510	弯管接头 elbow	1	1
15	154-50-11260	管 tube	1	1
16	07213-50510	管接头 nipple	1	1
17	07020-00000	直通式压注油杯 fitting, grease	1	1
18	08036-10614	管夹 clip	2	2
19	01010-51016	螺栓 bolt	2	2
20	01602-21030	弹簧垫圈 washer, spring	2	2

第 512 图 牵引架
FIG. 512 DRAWBAR

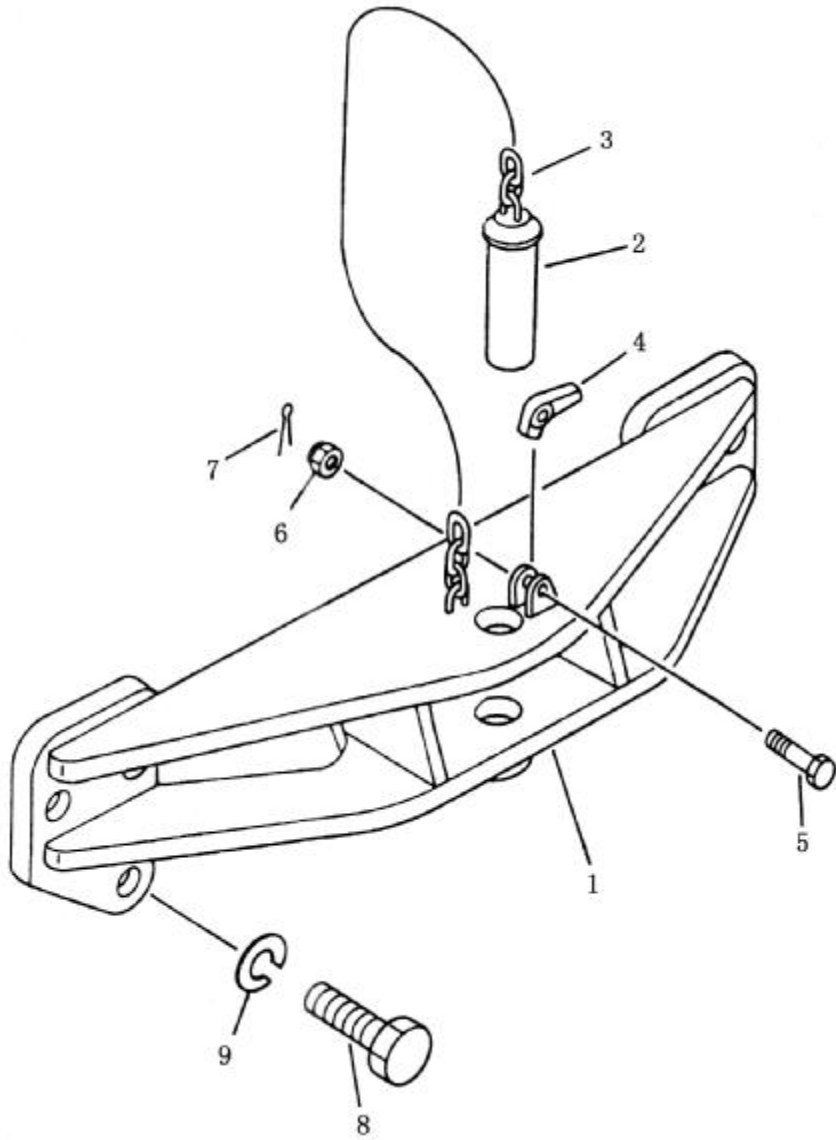

牵引架 DRAWBAR

序号 Index No.	件 号 Part No.	名 称 Description	数量 Q' ty
			SD22 SD22E SD22D
513-1	23Y-32-01000	牵引架合件 drawbar ass' y	1
2	TS220 •69 •2-1	牵引销 pin, drawbar	1
3	09245-24842	环形链环 chain	1
4	TS220 •69 •2-2	掣爪 latch	1
5	01052-51265	螺栓 bolt	1
6	01593-11215	螺母 nut	1
7	04050-13020	开口销 pin, cotter	1
8	01010-83380	螺栓 bolt	8
9	01643-33380	加厚垫圈 washer	8

第 513 图 牵引架(湿地型)
FIG. 513 DRAWBAR (For SD22S)

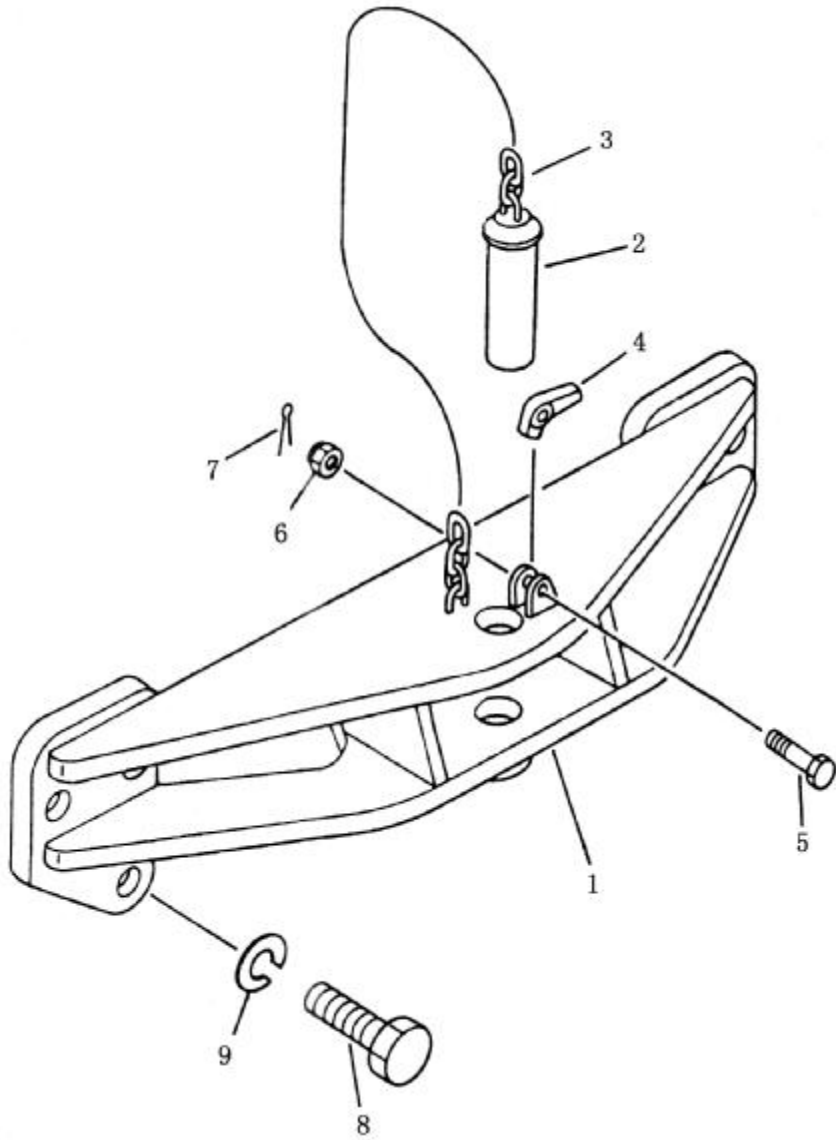

牵引架
DRAWBAR

序号 Index No.	件 号 Part No.	名 称 Description	数量 Q' ty
			SD22S
513-1	TS220·69·1	牵引架合件 drawbar ass' y	1
2	TS220·69·2-1	牵引销 pin, drawbar	1
3	09245-24842	环形链环 chain	1
4	TS220·69·2-2	掣爪 latch	1
5	01052-51265	螺栓 bolt	1
6	01593-11215	螺母 nut	1
7	04050-13020	开口销 pin, cotter	1
8	01010-83380	螺栓 bolt	6
9	01643-33380	加厚垫圈 washer	6

第 514 图 驾驶室
Fig. 514 CAB

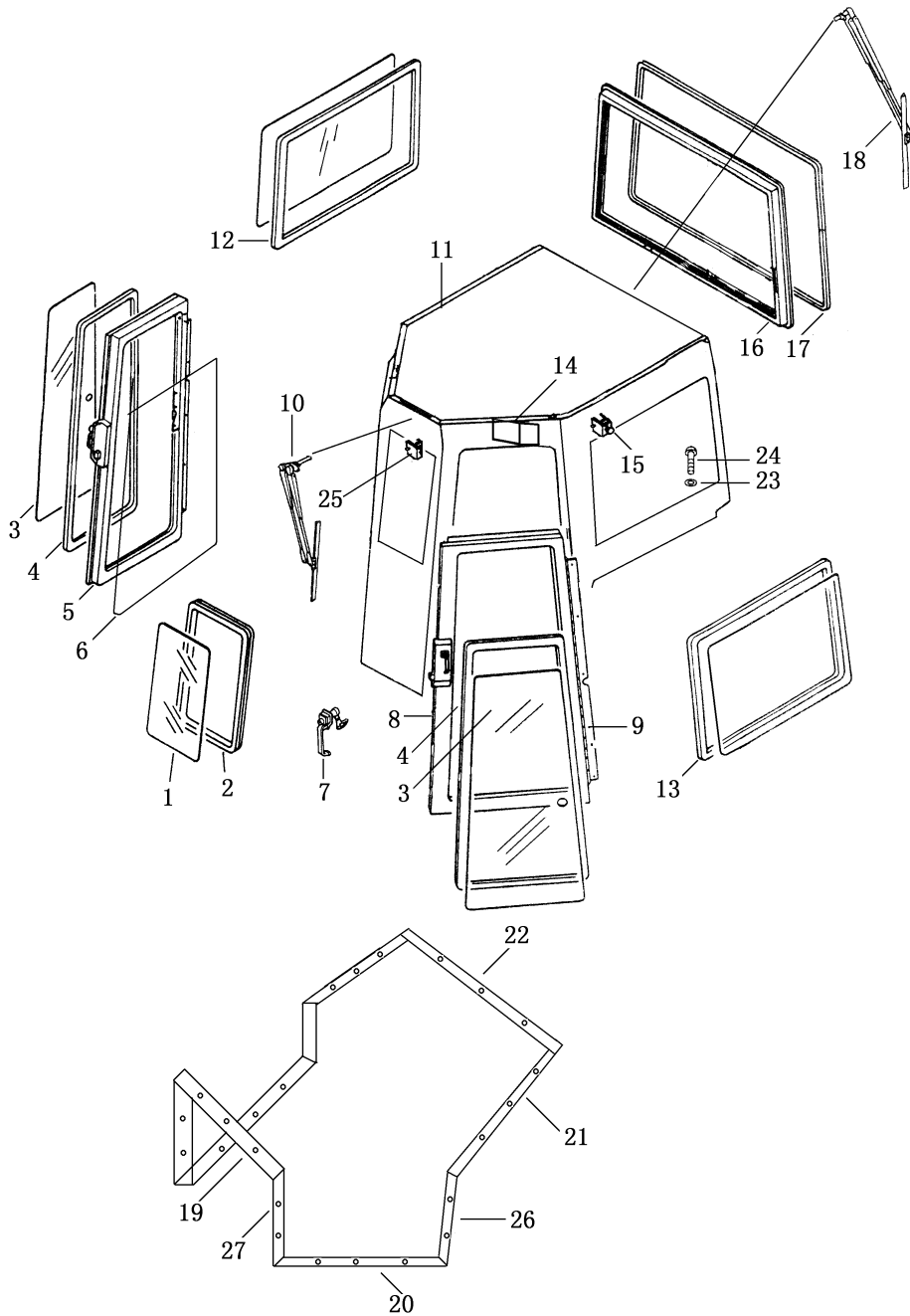

驾驶室
CAB

序号 Index No.	图 号 PART NO.	名 称 DESCRIPTION	数量 Q' ty
514-1	23Y-56B-00005	玻璃 glass	1
2	23Y-56B-00004	玻璃镶条 strip	1
3	23Y-56B-00003	玻璃 glass	2
4	23Y-56B-00002	玻璃镶条 strip	2
5	23Y-56B-03000	门框总成 (右) door frame, R.H	1
6	23Y-56B-06000	密封条 sealing strip	2
7	16Y-56A-02000	锁 lock	2
8	23Y-56B-02000	门框总成 (左) door, L.H	1
9	16Y-56A-03100	铰链 hinge	6
10	23Y-56B-04000	前雨刷 rain-brush, front	1
11	23Y-56B-01000	框架 frame	1
12	23Y-56B-08000	窗框总成 (右) window frame, R.H	1
13	23Y-56B-07000	窗框总成 (左) window frame, L.H	1
14	16Y-56C-00007	板 plate	2
15	10Y-56-08000	碰钩 touch hook	2
16	23Y-56B-00007	玻璃镶条 strip	1
17	23Y-56B-00008	玻璃 glass	1
18	23Y-56B-09000	后雨刷 rain-brush, rear	1
19	23Y-56B-00006	密封条 sealing strip	1
20	23Y-56B-00013	密封条 sealing strip	1
21	23Y-56B-00012	密封条 sealing strip	2
22	23Y-56B-00009	密封条 sealing strip	1
23	01643-31445	垫圈 washer	13
24	01010-51455	螺栓 bolt	13

第 515 图 司机座
FIG. 515 OPERATOR'S SEAT

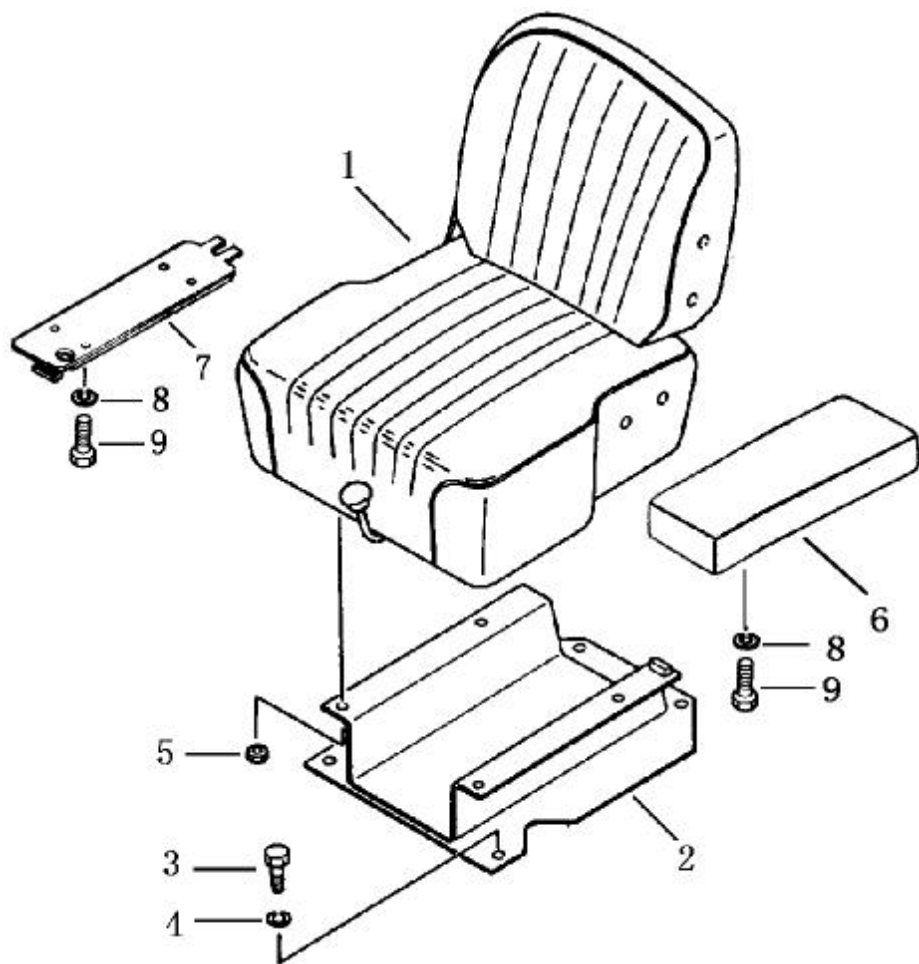

司机座

OPERATOR'S SEAT

序号 Index No.	件 号 Part No.	名 称 Description	数量 Q'ty
	23Y-53B-00000	司机座合件 seat ass'y	
515-1	10Y-53B-20000	司机座 seat	1
2	23Y-53B-01000	座 seat	1
3	01010-31225	螺栓 bolt	4
4	01643-31232	垫圈 washer	4
5	01580-01210	螺母 nut	4
6	23Y-53B-02000	扶手 arm rest	1
7	23Y-53B-00001	板 plate	1
8	01643-31032	垫圈 washer	3
9	01010-31025	螺栓 bolt	3

附属装置控制系统
ATTACHMENT CONTROL SYSTEM

第 601 图 液 压 泵
 FIG. 601 HYDRAULIC PUMP

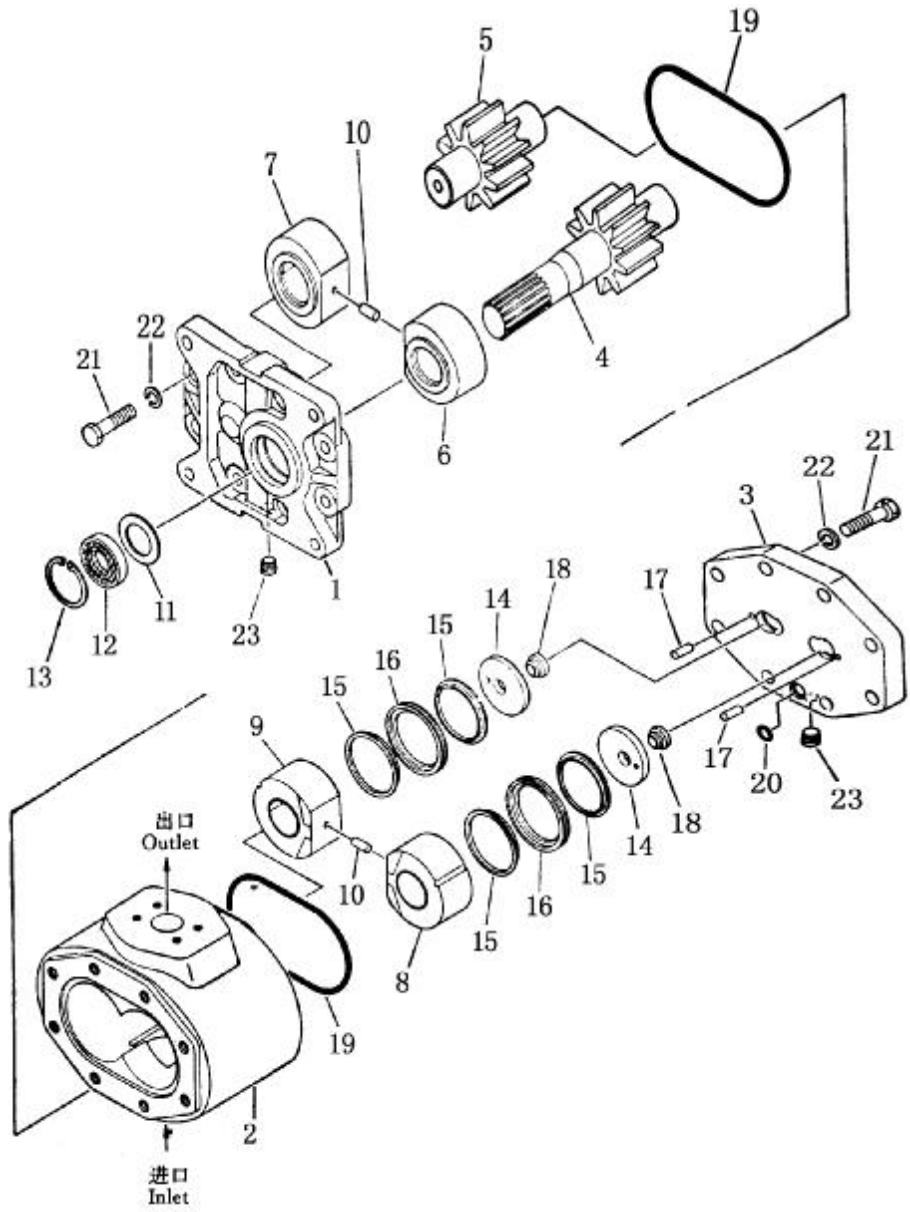

液 压 泵
HYDRAULIC PUMP

序号 Index No.	件 号 Part No.	名 称 Description	数量 Q' ty
601-(1~10, 14~23)	(07444-66103)	液压泵总成 hydraulic pump ass' y	1
11	07440-66110	垫板 plate	1
12	07438-11162	油封 seal, oil	1
13	04065-05520	开口环 ring, snap	1

第 602 图 液压箱 (1/2)
 FIG. 602 HYDRAULIC TANK

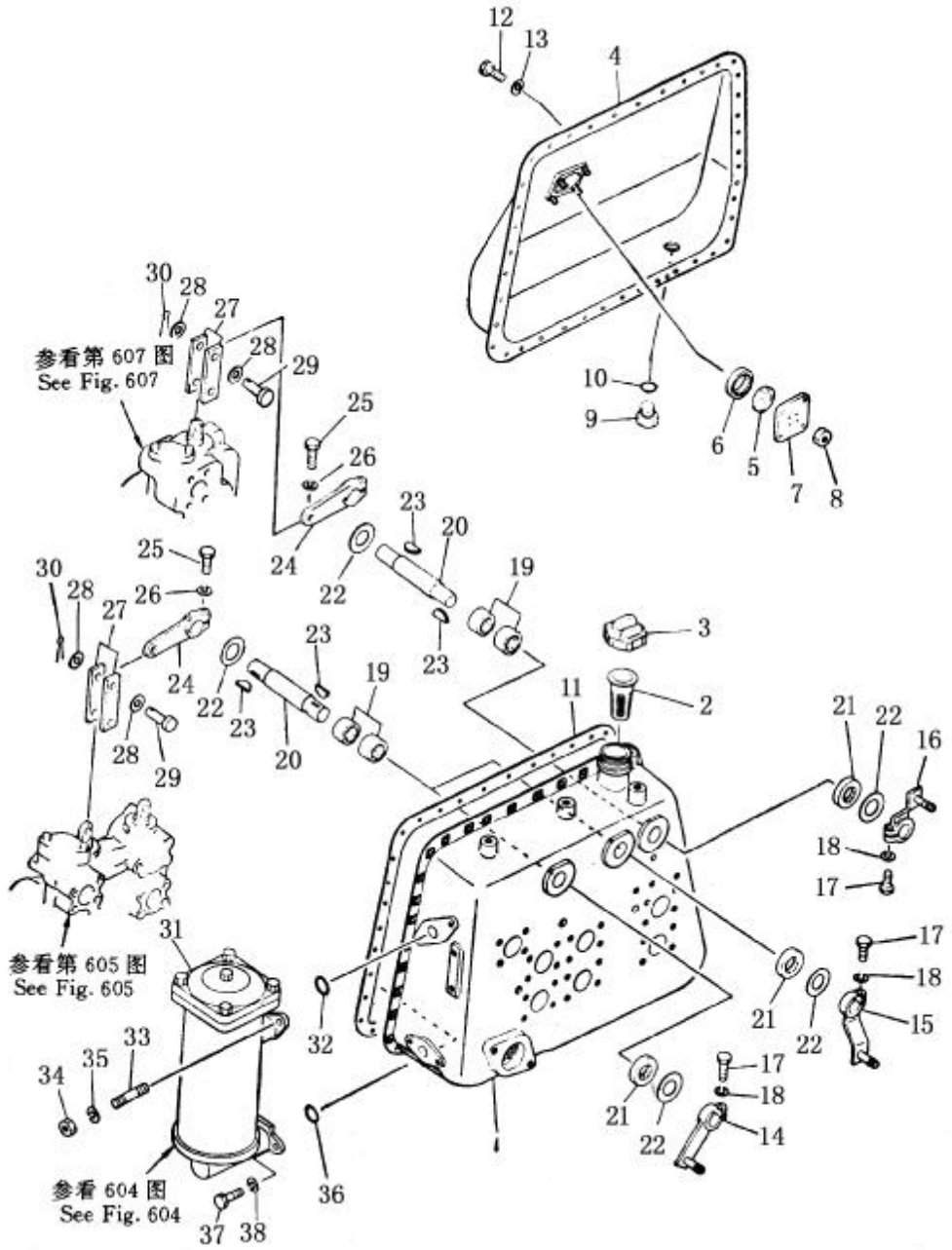

液 压 箱 (1/2)

HYDRAULIC TANK

序号 Index No.	件 号 Part No.	名 称 Description	数量 Q' ty
	23Y-60B-00000	液压箱总成 hydraulic tank ass' y	1
602-1	23Y-60B-01000	液压箱 (内侧) tank, inner	1
2	141-60-33730	滤油器 strainer	1
3	07051-00000	帽 cap	1
4	141-60-43160	液压箱 (外侧) tank, outer	1
5	07715-11257	环 ring	1
6	07715-00651	盖 cover	1
7	07115-21074	盖 cage	1
8	01598-11011	螺母 nut	4
9	07044-12412	螺塞 plug	1
10	07002-02434	O型圈 O-ring	1
11	141-60-33181	填密垫 gasket	1
12	01010-51025	螺栓 bolt	41
13	01602-21030	弹簧垫圈 washer, spring	41
14	23Y-60B-02000	杠杆 (升降) lever, lift	1
15	23Y-60B-03000	杠杆 (倾斜) lever, tilt	1
16	23Y-60B-04000	杠杆 (松土) lever, ripper	1
17	01010-50830	螺栓 bolt	3
18	01602-20825	弹簧垫圈 washer, spring	3
19	06120-02520	滚针轴承 bearing, needle	6
20	154-60-51450	轴 shaft	3
21	154-60-12370	油封 seal, oil	3
22	01640-22440	垫圈 washer	6
23	04010-00519	键 key	6
24	141-60-33270	杠杆 lever	3
25	01010-50830	螺栓 bolt	3
26	01602-20825	弹簧垫圈 washer, spring	3
27	141-60-32170	轭 yoke	6
28	01641-01016	垫圈 washer	6
29	04205-01028	销 pin	6
30	04050-03015	开口销 pin, cotter	6
31	154-60-51401	过滤器总成 hydraulic filter ass' y	1
32	07000-03050	O型圈 O-ring	1
33	01140-51430	双头螺栓 stud	2
34	01582-11411	螺帽 nut	2
35	01602-21442	弹簧垫圈 washer, spring	2
36	07000-02065	O型圈 O-ring	1
37	01010-51430	螺栓 bolt	2
38	01602-21442	弹簧垫圈 washer, spring	2

第 603 图 液压箱 (2/2)
 FIG. 603 HYDRAULIC TANK

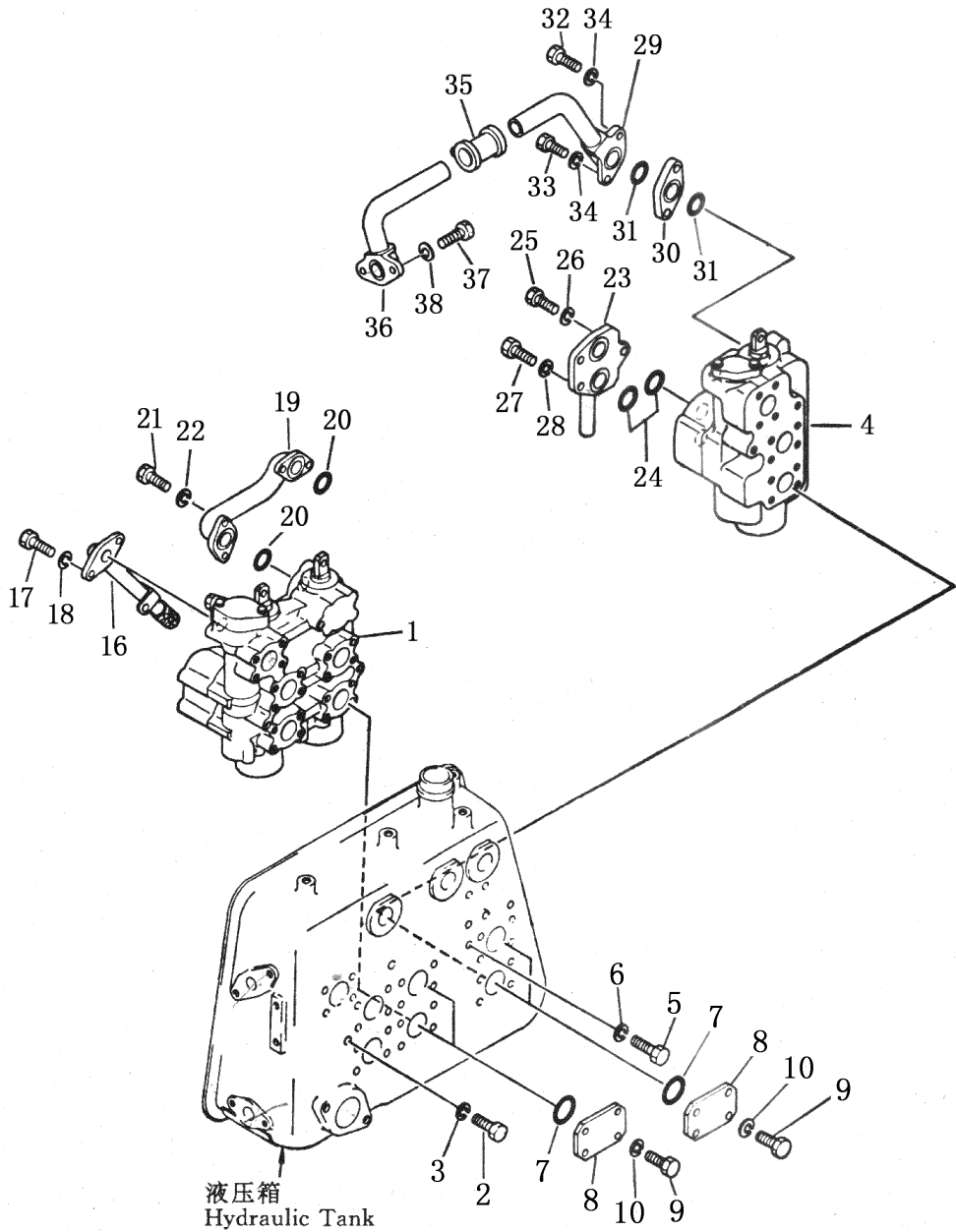

液压箱 (2/2)
HYDRAULIC TANK

序号 Index No.	件号 Part No.	名称 Description	数量 Q' ty
603-1	701-34-11002	铲刀升降及倾斜控制阀总成 blade, lift and tilt control valve ass' y	1
2	01010-51225	螺栓 bolt	3
3	01602-21236	弹簧垫圈 washer, spring	3
4	701-32-27001	松土控制阀总成 ripper control valve ass' y	1
5	01010-51225	螺栓 bolt	2
6	01602-21236	弹簧垫圈 washer, spring	2
7	07000-13048	O型圈 O-ring	4
8	07378-01460	凸缘 flange	4
9	01010-51240	螺栓 bolt	16
10	01602-21236	弹簧垫圈 washer, spring	16
16	154-60-52160	管 tube	1
17	01010-30830	螺栓 bolt	2
18	01602-00825	弹簧垫圈 washer, spring	2
19	154-60-51360	管 tube	1
20	07000-13045	O型圈 O-ring	2
21	01010-31445	螺栓 bolt	4
22	01602-01442	弹簧垫圈 washer, spring	4
23	144-78-13170	管 tube	1
24	07000-03032	O型圈 O-ring	2
25	01010-30825	螺栓 bolt	1
26	01602-00825	弹簧垫圈 washer, spring	1
27	01010-31220	螺栓 bolt	2
28	01602-01236	弹簧垫圈 washer, spring	2
29	154-60-51411	管 tube	1
30	154-60-51421	凸缘 flange	1
31	07000-03042	O型圈 O-ring	2
32	01010-31490	螺栓 bolt	1
33	01010-31465	螺栓 bolt	1
34	01602-01442	弹簧垫圈 washer, spring	2
35	07332-01200	连接器 coupling	1
36	154-60-51383	管 tube	1
37	01010-31435	螺栓 bolt	2
38	01602-01442	弹簧垫圈 washer, spring	2

第 604 图 液压滤油器
FIG.604 HYDRAULIC FILTER

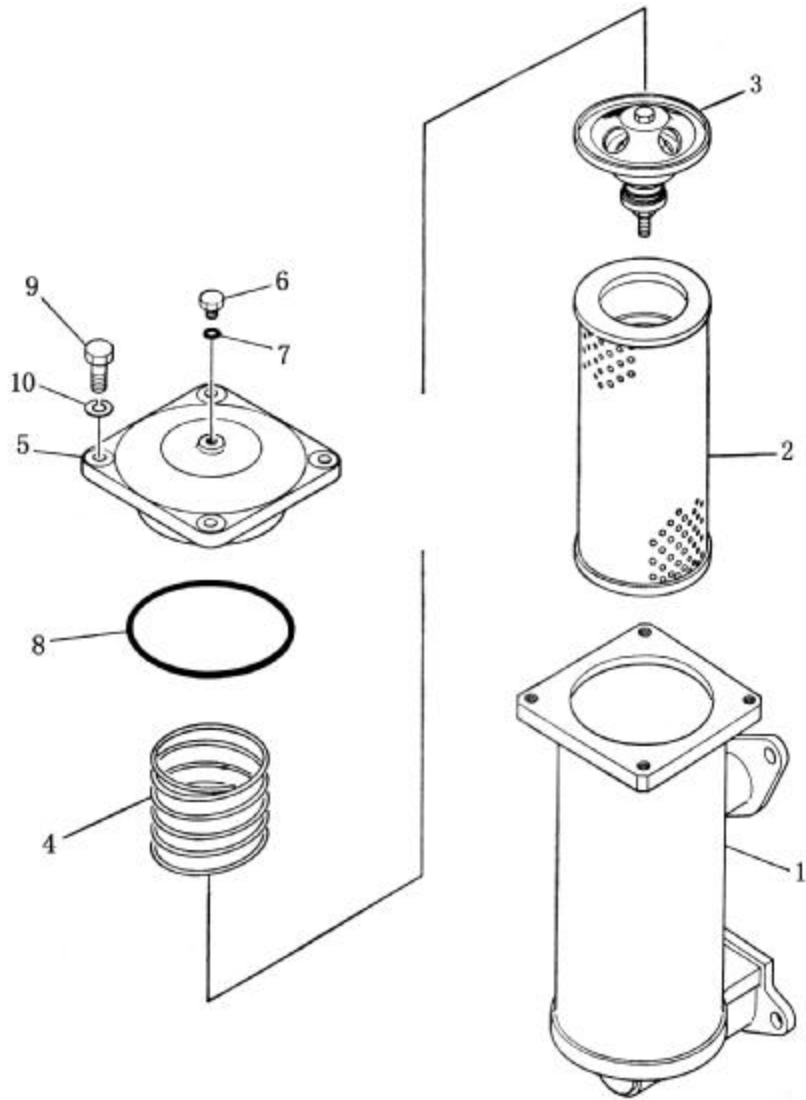

液 压 滤 油 器
HYDRAULIC FILTER

序号 Index No.	件 号 Part No.	名 称 Description	数量 Q' ty
	154-60-51401	液压滤油器总成 hydraulic filter ass' y	1
604-1	154-60-51392	壳体 case	1
2	175-60-27380	(滤芯) 组件 element	1
3	175-60-27300	阀总成 valve ass' y	1
4	175-60-27340	弹簧 spring	1
5	175-60-27171	盖 cover	1
6	154-60-12260	塞 plug	1
7	07000-02010	O 型圈 O-ring	1
8	07000-05150	O 型圈 O-ring	1
9	01010-51235	螺栓 bolt	4
10	01602-21236	弹簧垫圈 washer, spring	4

第 605 图 铲刀提升和倾斜操纵阀 (1/2)
 FIG. 605 BLADE LIFT AND TILT CONTROL VALVE

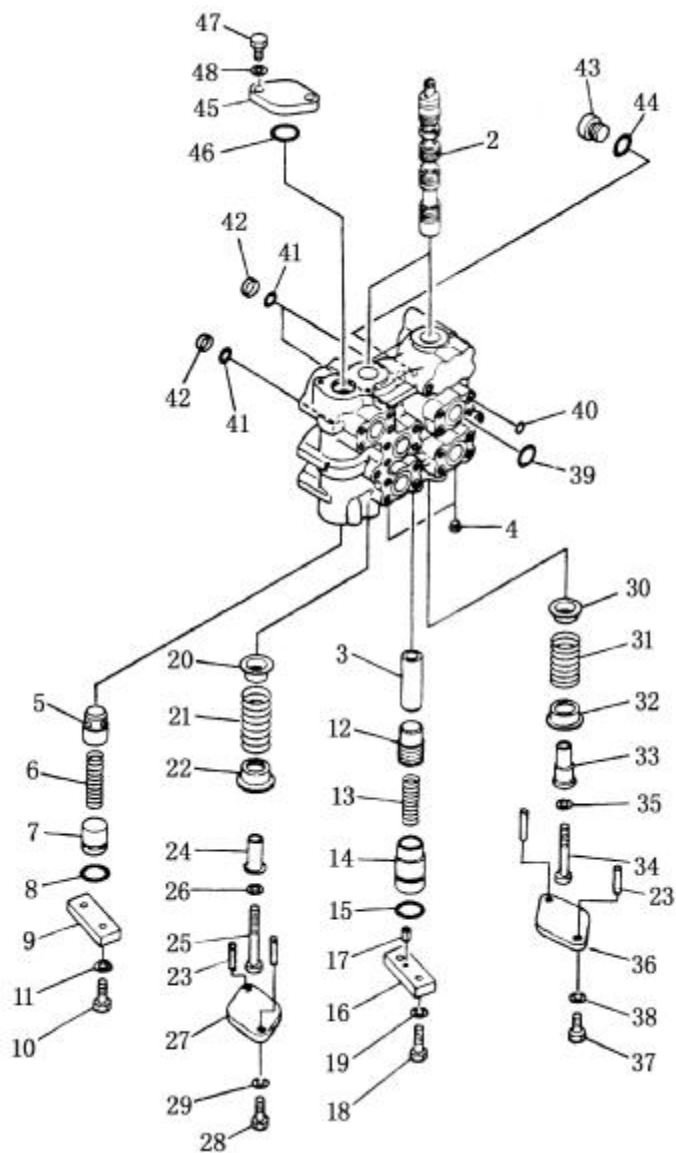

铲刀提升和倾斜操纵阀（1/2）
BLADE LIFT AND TILT CONTROL VALVE

序号 Index No.	件号 Part No.	名称 Description	数量 Q' ty		
605-1	701-34-11002	铲刀提升和倾斜 操纵阀总成	blade lift and tilt control valve ass' y	1	
	701-33-48001	阀组件	control valve ass' y	1	
	701-33-46310	阀体	body, valve	1	
	2	701-33-31430	（提升和倾斜滑阀）	spool, lift and tilt	2
	3	701-33-46320	套管	collar	1
	4	07043-00415	堵	plug	2
	5	701-33-31120	（单向）阀	valve, check	1
	6	701-33-31130	弹簧	ring	1
	7	701-33-31150	座	seat	1
	8	07000-13035	O型圈	O-ring	1
	9	701-33-31160	板	plate	1
	10	01010-51235	螺栓	bolt	2
	11	01602-21236	弹簧垫圈	washer, spring	2
	12	701-21-33130	（单向）阀	valve, check	1
	13	701-21-33140	弹簧	spring	1
	14	701-33-46330	座	seat	1
	15	07000-12018	O型圈	O-ring	1
	16	701-33-32160	板	plate	1
	17	04020-00514	定位销	pin, dowel	1
	18	01010-51240	螺栓	bolt	2
	19	01602-21236	垫圈	washer	2
	20	701-33-31380	挡圈	retainer	1
	21	701-33-31191	弹簧	ring	1
	22	701-33-31380	挡圈	retainer	1
	23	701-33-46350	套管	collar	4
	24	701-33-46171	套管	collar	1
	25	01010-51280	螺栓	bolt	1
	26	01602-21236	垫圈	washer	1
27	701-33-46340	板	plate	1	
28	01010-51095	螺栓	bolt	2	

铲刀提升和倾斜操纵阀 (1/2)
BLADE LIFT AND TILT CONTROL VALVE

序号 Index No.	件 号 Part No.	名 称 Description	数量 Q' ty
605-29	01602-21030	垫圈 washer	2
30	701-33-31380	挡圈 retainer	1
31	701-33-31191	弹簧 ring	1
32	701-33-31380	挡圈 retainer	1
33	701-33-46171	套管 collar	1
34	01010-51280	螺栓 bolt	1
35	01602-21236	垫圈 washer	1
36	701-33-46340	板 plate	1
37	01010-51095	螺栓 bolt	2
38	01602-21030	垫圈 washer	2
39	07000-13045	O 型圈 O-ring	5
40	07000-02015	O 型圈 O-ring	23
41	07000-13035	O 型圈 O-ring	2
42	701-40-61180	衬垫环 ring, back-up	2
43	07040-13016	堵 plug	2
44	07002-13034	O 型圈 O-ring	2
45	701-33-31360	盖 cover	1
46	07000-13040	O 型圈 O-ring	1
47	01010-51440	螺栓 bolt	2
48	01602-21442	垫圈 washer	2

第 606 图 铲刀提升和倾斜操纵阀 (2/2)
FIG. 606 BLADE LIFT AND TILT CONTROL VALVE

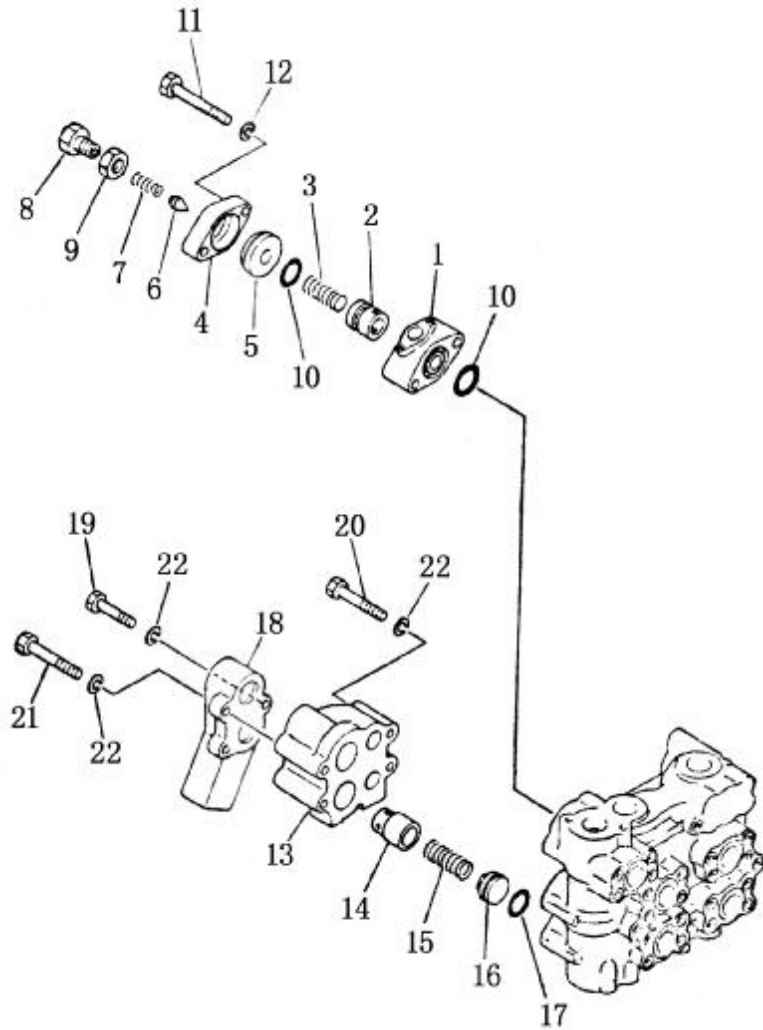

铲刀提升和倾斜操纵阀 (2/2)
BLADE LIFT AND TILT CONTROL VALVE

序号 Index No.	件 号 Part No.	名 称 Description	数量 Q' ty
	701-34-11002	铲刀提升和倾 斜操纵阀总成 blade lift and tilt control valve ass' y	1
	701-30-51002	主安全阀总成 main relief valve ass' y	1
606-1	701-30-51111	(安全阀) 外壳 housing, relief valve	1
2	701-30-51120	阀 valve, relief	1
3	701-30-51130	弹簧 spring	1
4	701-30-51140	座 body	1
5	701-30-51151	阀座 seat, valve	1
6	701-30-51160	提升阀 poppet	1
7	701-30-51171	弹簧 spring	1
8	701-10-51160	螺塞 plug	1
9	701-30-51190	螺母 nut	1
10	07000-13048	O 型圈 o-ring	2
11	01011-51405	螺栓 bolt	2
12	01602-21442	弹簧垫圈 washer, spring	2
	701-40-61002	补油阀总成 suction valve ass' y	1
13	701-40-61152	阀体 body, suction valve	1
14	701-40-61120	阀 valve	2
15	701-50-61131	弹簧 spring	2
16	701-40-72120	座 body	2
17	07000-13040	O 型圈 o-ring	2
18	701-40-67110	补油管 baffle	1
19	01010-51480	螺栓 bolt	1
20	01010-51495	螺栓 bolt	2
21	01011-51435	螺栓 bolt	2
22	01602-21442	弹簧垫圈 washer, spring	5

第 607 图 松土器控制阀 (1/2)
FIG. 607 RIPPER CONTROL VALVE

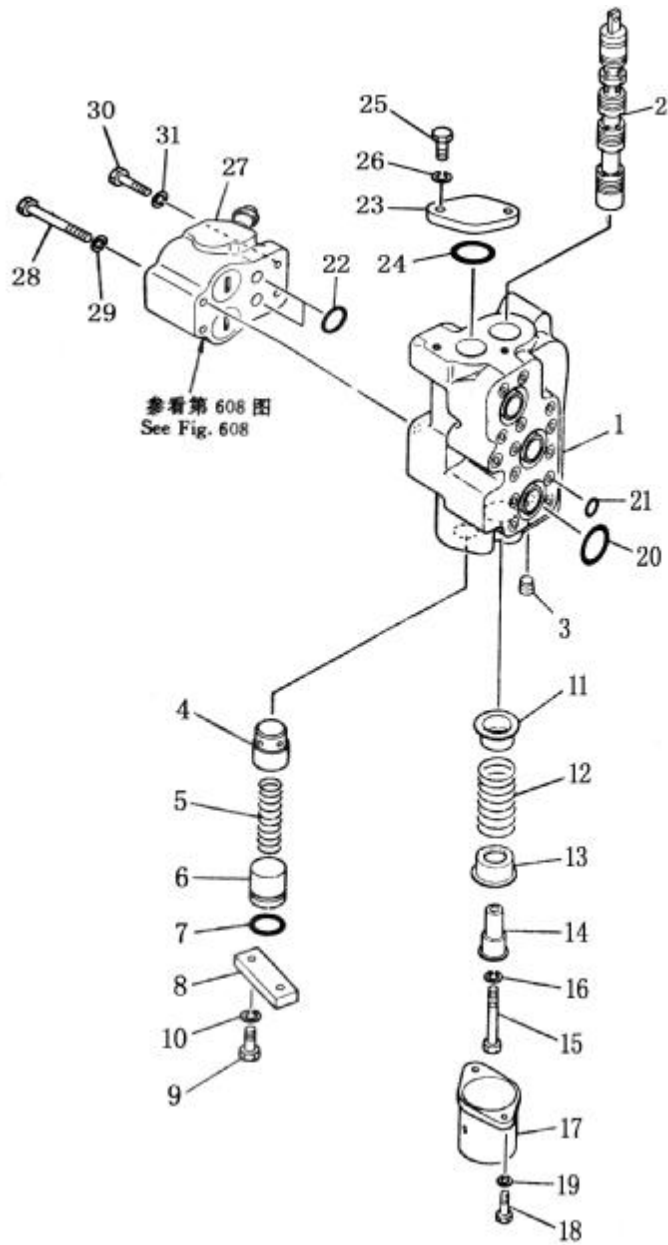

松土器控制阀 (1/2)
RIPPER CONTROL VALVE

序号 Index No.	件 号 Part No.	名 称 Description	数量 Q' ty
	701-32-27001	松土器控制阀组件 ripper control valve ass' y	1
	701-32-42001	控制阀总成 control valve ass' y	1
607-1, 2	701-31-32112	阀体总成 body ass' y	1
3	07043-00312	螺塞 plug	1
4	701-33-31120	阀 valve	1
5	701-33-31130	弹簧 spring	1
6	701-33-31150	垫座 seat	1
7	07000-13035	O 型圈 o-ring	1
8	701-33-31160	垫板 plate	1
9	01010-51235	螺栓 bolt	2
10	01602-21236	弹簧垫圈 washer, spring	2
11	701-33-31380	护圈 retainer	1
12	701-33-31191	弹簧 spring	1
13	701-33-31380	护圈 retainer	1
14	701-33-46171	套环 collar	1
15	01010-51280	螺栓 bolt	1
16	01602-21236	弹簧垫圈 washer, spring	1
17	701-33-46340	箱 case	1
18	01010-51095	螺栓 bolt	2
19	01602-21030	弹簧垫圈 washer, spring	2
20	07000-13045	O 型圈 o-ring	3
21	07000-12015	O 型圈 o-ring	14
22	07000-13030	O 型圈 o-ring	2
23	701-33-31360	盖 cover	1
24	07000-13040	O 型圈 o-ring	1
25	01010-51440	螺栓 bolt	2
26	01602-21442	弹簧垫圈 washer, spring	2
27	701-30-99000	吸进及安全阀总成 suction and safety ass' y	1
28	01011-51210	螺栓 bolt	2
29	01602-21236	弹簧垫圈 washer, spring	2
30	01010-51245	螺栓 bolt	2
31	01602-21236	弹簧垫圈 washer, spring	2

第 608 图

松土器控制阀 (2/2)

FIG. 608

RIPPER CONTROL VALVE

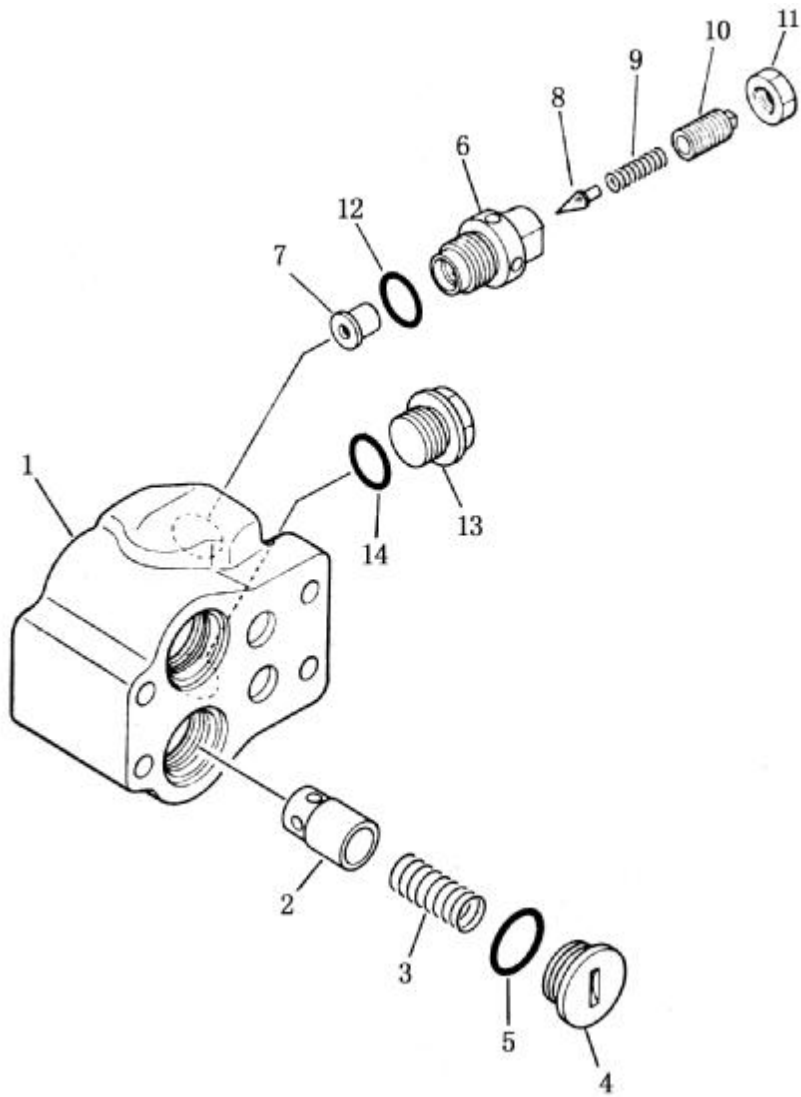

松土器控制阀 (2/2)
RIPPER CONTROL VALVE

序号 Index No.	件 号 Part No.	名 称 Description	数量 Q' ty	
	701-30-99000	吸进和安 全阀总成	suction and safety valve ass' y	1
608-1	701-30-99110	进气和安 全阀箱	housing, suction and safety valve	1
2	701-30-67121	吸进阀	valve, suction	2
3	701-30-67130	弹簧	spring	2
4	701-30-67160	螺塞	plug	2
5	07002-13634	O 型圈	o-ring	2
6~11	701-30-00080	安全阀总成	safety valve ass' y	1
12	07002-13034	O 型圈	o-ring	1
13	07041-13012	螺塞	plug	1
14	07002-13034	O 型圈	o-ring	1

第 609 图 铲刀提升油缸(1/2)
 FIG. 609 BLADE LIFT CYLINDER

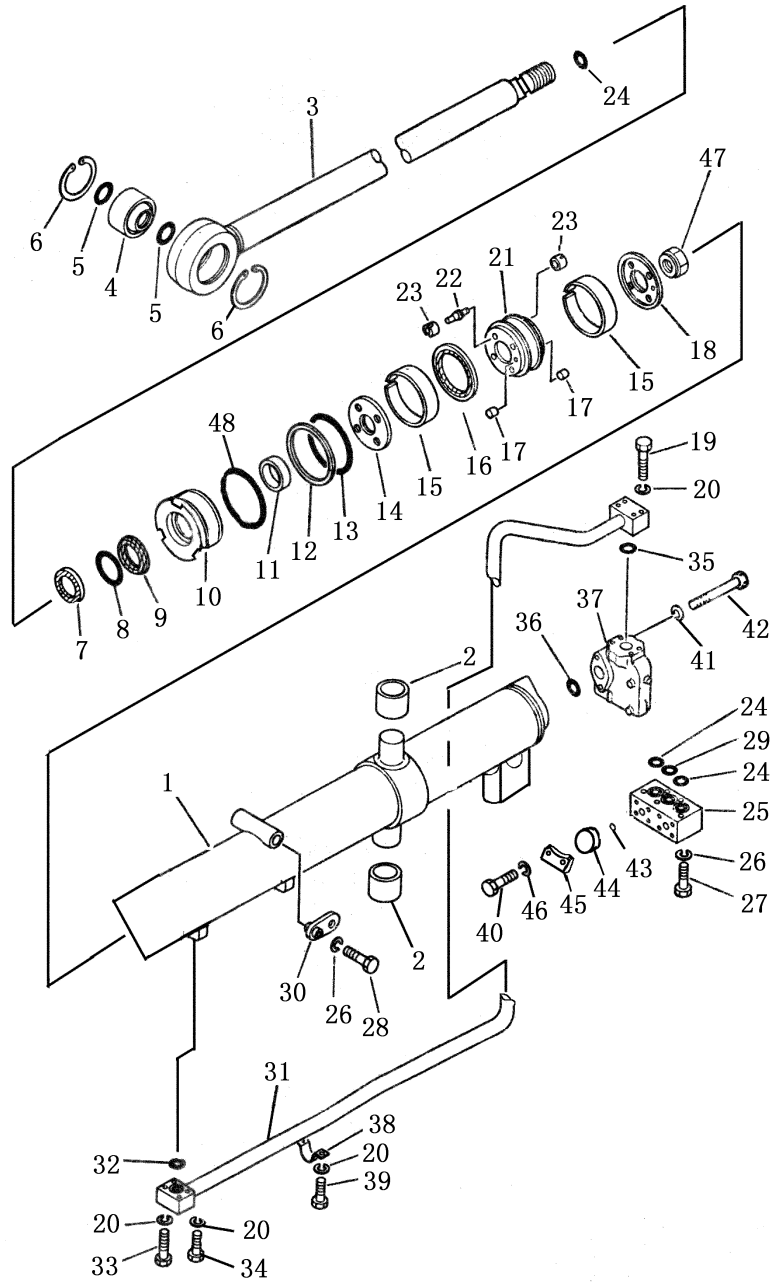

铲刀提升油缸(1/2)
BLADE LIFT CYLINDER

序号 Index No	图 号 PART NO.	名 称 DESCRIPTION	数量 Q'ty		
			SD22	SD22S	SD22E SD22D
609-1	23Y-62B-01000	油缸总成 (左) cylinder ass'y L.H	1		
	23Y-62B-02000	油缸总成 (右) cylinder ass'y R.H	1		
	158-62-01000	油缸总成 (左) cylinder ass'y L.H		1	
	158-62-02000	油缸总成 (右) cylinder ass'y R.H		1	
	23Y-65E-A0000	油缸总成 (左) cylinder ass'y L.H			1
	23Y-65E-A0000	油缸总成 (右) cylinder ass'y R.H			1
	23Y-62B-01200	缸体 body, cylinder	2		
	158-62-01100	缸体(左) body, cylinder, L.H		1	
	158-62-02100	缸体 (右) body, cylinde, R.H		1	
	23Y-65E-03000	缸体 body, cylinder			2
	2	154-63-12340	衬套 bushing	4	4
3	23Y-62B-01300	活塞杆 rod, piston	2		2
	158-62-01200	活塞杆 rod, piston		2	
4	07137-04507	衬套 bushing	2	2	2
5	07000-03045	O 形圈 O-ring	4	4	4
6	04065-01030	挡圈 ring, stopper	4	4	4
7	23Y-62B-01001	防尘圈 seal, dust	2	2	2
8	23Y-62B-01002	KY 圈 KY-ring	2	2	2
9	23Y-62B-01100	斯特封 seal	2	2	2
10	23Y-62B-01006	缸头 head, cylinder	2	2	2
11	23Y-62B-01003	导向环 ring, guide	2	2	2
12	07146-02116	支撑圈 ring, support	2	2	2
13	07000-12115	O 形圈 O-ring	2	2	2
14	23Y-62B-01004	挡板 plate, stopper	2	2	2
15	23Y-62B-01005	支承环 ring, support	4	4	4
16	23Y-62B-01500	格莱圈 ring	2	2	2
17	130-63-12761	销 pin	4	4	4
18	707-40-12030	挡板 plate, stopper	2	2	2
19	01010-51065	螺栓 bolt	8	8	8
20	01643-31032	垫圈 washer	20	20	20
21	23Y-62B-01401	活塞 piston	2	2	2
22	154-63-12471	活塞阀 valve, piston	8	8	8
23	154-63-12860	阀座 pedestal, valve	16	16	16
24	07000-13038	O 形圈 O-ring	6	6	6
25	154-63-12550	弯头 elbow	2		2
	TS220.631.3	管 tube		2	

铲刀提升油缸
BLADE LIFT CYLINDER

序号 Index No.	图号 PART NO.	名称 DESCRIPTION	数量 Q' ty		
			SD22	SD22S	SD22E SD22D
26	01643-31232	垫圈 washer	12	14	14
27	01010-51270	螺栓 bolt	10	10	10
28	01010-51245	螺栓 bolt	2	4	4
29	07000-13045	O形圈 O-ring	2	2	2
30	154-61-11621	联板 plate	2		2
	TS220.631.5	联板 plate		2	
31	23Y-62B-01600	管(左) tube, L.H	1		
	23Y-62B-02100	管(右) tube, R.H	1		
	158-62-01300	管(左) tube, L.H		1	1
	158-62-02200	管(右) tube, R.H		1	1
	23Y-65E-04000	管 tube			2
32	07000-13035	O形圈 O-ring	2	2	2
33	01010-51050	螺栓 bolt	4	4	4
34	01010-51055	螺栓 bolt	4	4	4
35	07000-13048	O形圈 O-ring	2	2	2
36	07000-12055	O形圈 O-ring	2	2	2
37	154-63-14001	快降阀总成 quick drop valve ass'y	2	2	2
38	07282-03411	管夹 clip	2	2	2
39	01010-51020	螺栓 bolt	4	4	4
40	01010-50830	螺栓 bolt	16		
41	01643-31645	垫圈 washer	4	4	4
42	01010-51615	螺栓 bolt	4	4	4
43	07000-13025	O形圈 O-ring	4		
44	07378-10600	防尘盖 cap	4		
45	07371-30638	分离式法兰 flange, split	8		
46	01643-30823	垫圈 washer	16		
47	07165-13941	螺母 nut	2	2	2
48	07000-02120	O形圈 O-ring	2	2	2

第 610 图 铲刀提升油缸(2/2)
FIG. 610 BLADE LIFT CYLINDER

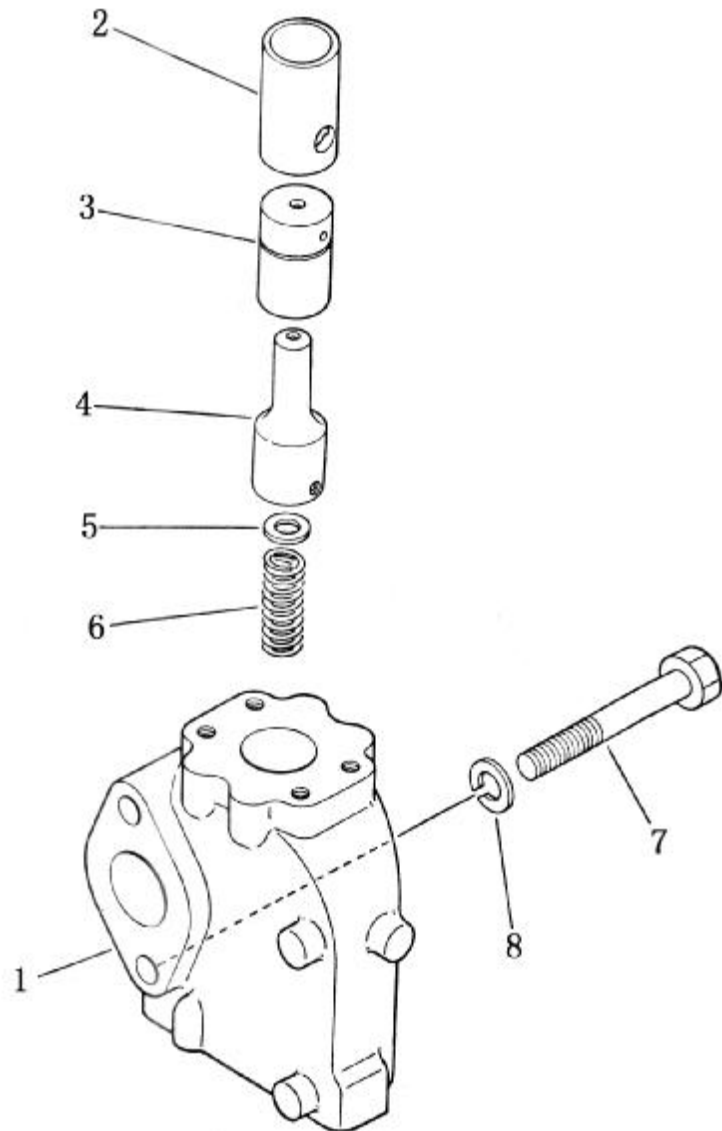

铲刀提升油缸 (2/2)
BLADE LIFT CYLINDER

序号 Index No.	图 号 PART NO.	名 称 DESCRIPTION	数量 Q' ty
610-1,3,4	154-63-14001	快降阀总成 quick drop valve ass'y	1
2	195-63-14161	套环 bushing	1
5	01642-21216	垫圈 washer	1
6	195-60-14180	弹簧 spring	1
7	01010-51615	螺栓 bolt	2
8	01643-31645	垫圈 washer	2

第 611 图 倾斜油缸
FIG. 611 BLADE TILT CYLINDER

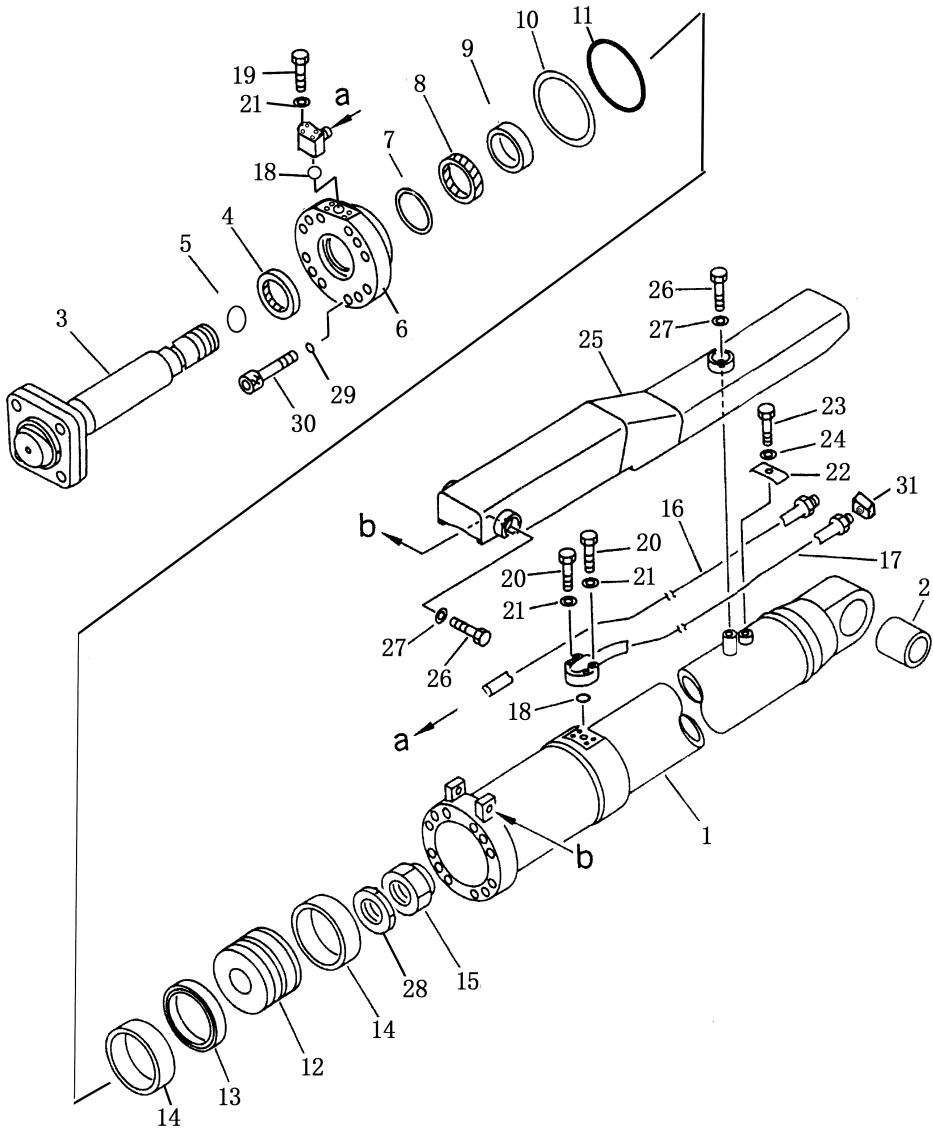

倾 斜 油 缸
BLADE TILT CYLINDER

序号 Index No.	图号 PART NO.	名称 DESCRIPTION	数量 Q' ty
611-1	23Y-63B-01100	缸体 body, cylinder	1
2	154-63-52760	衬套 bushing	1
3	23Y-63B-01200	活塞杆 rod, piston	1
4	23Y-63B-01004	防尘圈 seal, dust	1
5	07000-13062	O 形圈 O-ring	1
6	23Y-63B-01002	缸头 head, cylinder	1
7	23Y-63B-01005	KY 圈 ky-ring	1
8	23Y-63B-01300	斯特封 seal	1
9	23Y-63B-01003	导向环 ring, guide	1
10	07146-05192	保护挡圈 ring, stopper	1
11	07000-15190	O 形圈 O-ring	1
12	23Y-63B-01001	活塞 piston	1
13	23Y-63B-01400	格莱圈 ring	1
14	23Y-63B-01006	支承环 ring, support	2
15	07165-16264	螺母 nut	1
16	154-63-52184	管 tube	1
17	154-63-52284	管 tube	1
18	07000-13030	O 形圈 O-ring	2
19	01010-50860	螺栓 bolt	4
20	01010-50845	螺栓 bolt	4
21	01643-30823	垫圈 washer	8
22	195-63-52871	弓形夹 clip	1
23	01010-51225	螺栓 bolt	1
24	01643-31232	垫圈 washer	1
25	154-63-52684	盖 cover	1
26	01010-51435	螺栓 bolt	3
27	01643-31645	垫圈 washer	3
28	154-63-52370	垫圈 washer	1
29	01643-32060	垫圈 washer	12
30	01010-52090	螺栓 bolt	12
31	154-63-52890	塞子 plug	2

第 612 图 液压管路（自箱至泵）
 FIG. 612 HYDRAULIC PIPING (TANK TO PUMP)

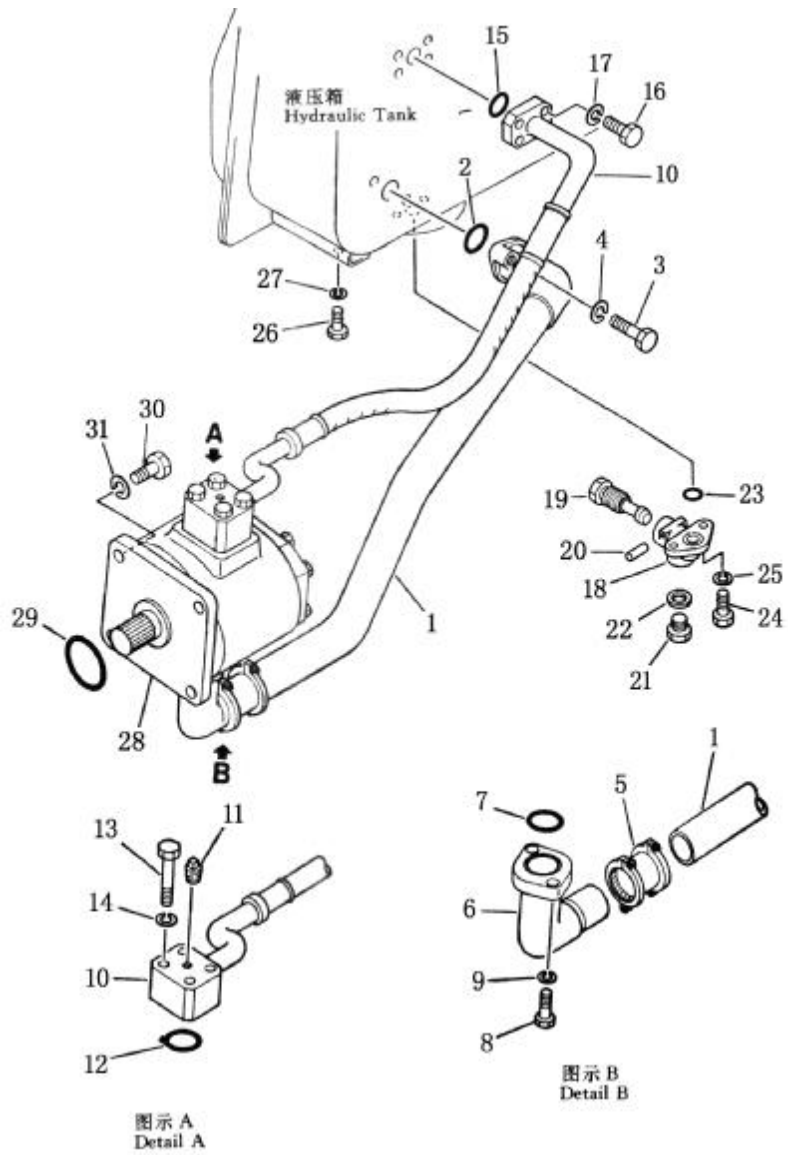

液压管路（自箱至泵）
HYDRAULIC PIPING（TANK TO PUMP）

序号 Index No.	件号 Part No.	名称 Description	数量 Q' ty
612-1	154-60-21113	管 tube	1
2	07000-02075	O型圈 o-ring	1
3	01011-51415	螺栓 bolt	2
4	01602-21442	垫圈 washer	2
5	07332-02000	连接器总成 coupling ass' y	1
6	154-60-21142	管 tube	1
7	07000-02070	O型圈 o-ring	1
8	01010-51245	螺栓 bolt	2
9	01602-21236	垫圈 washer	2
10	154-60-21422	软管 hose	1
11	07042-20108	螺塞 plug	1
12	07000-13042	O型圈 o-ring	1
13	01010-51075	螺栓 bolt	4
14	01602-21030	垫圈 washer	4
15	07000-13048	O型圈 o-ring	1
16	01010-51250	螺栓 bolt	4
17	01602-21236	垫圈 washer	4
	(155-60-12500)	阀总成 valve ass' y	1
18	155-60-12510	阀体 body, valve	1
19	155-60-12520	阀 valve	1
20	04025-00532	弹簧销 pin, spring	1
21	07040-12412	螺塞 plug	1
22	07005-02416	填密垫 gasket	1
23	07000-03025	O型圈 o-ring	1
24	01010-51025	螺栓 bolt	2
25	01602-21648	垫圈 washer	2
26	01010-51640	螺栓 bolt	4
27	01602-21648	垫圈 washer	4
28	(07444-66103)	液压泵总成 hydraulic pump ass' y	1
29	07000-03078	O型圈 o-ring	1
30	01010-51245	螺栓 bolt	4
31	01602-21236	垫圈 washer	4

第 613 图 液压管路（自箱至升降缸）（1/2）
 FIG. 613 HYDRAULIC PIPING (TANK TO LIFT CYLINDER)

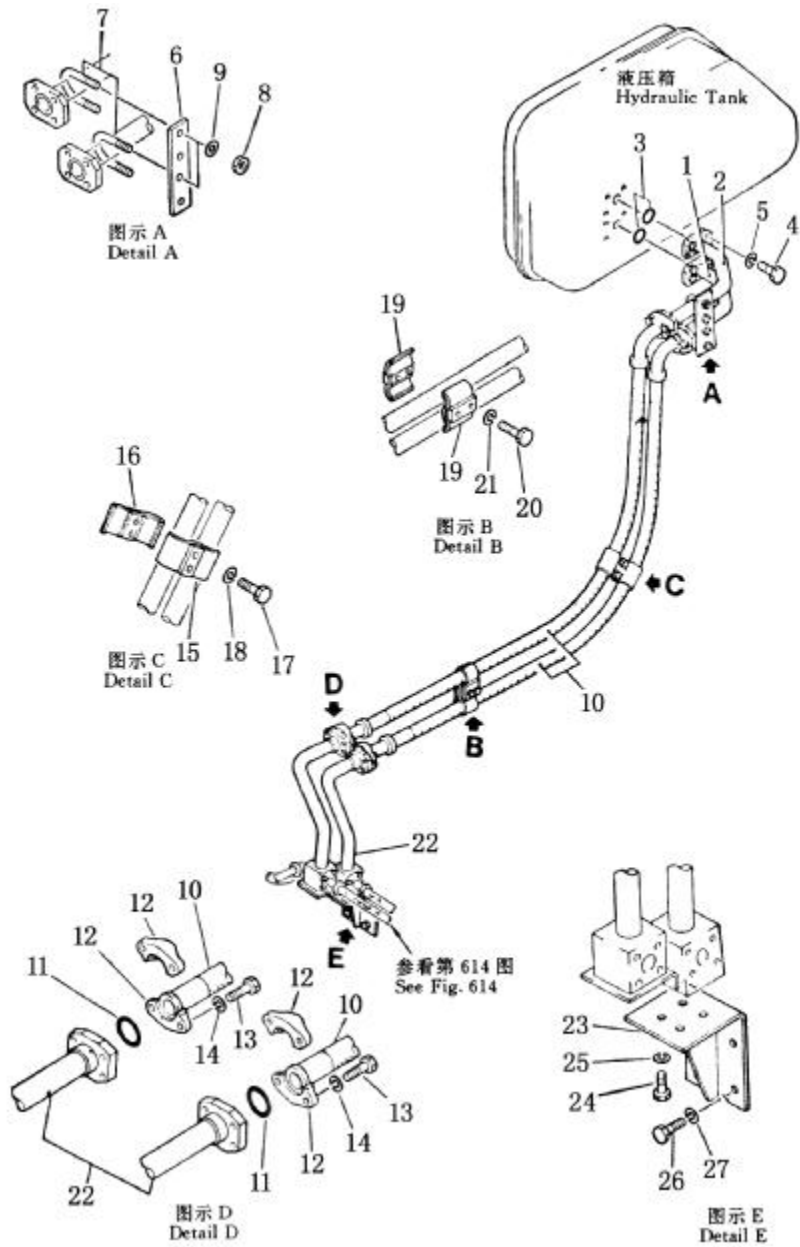

液压管路（自箱至升降缸）（1/2）
HYDRAULIC PIPING（TANK TO LIFT CYLINDER）

序号 Index No.	件号 Part No.	名称 Description	数量 Q' ty
			SD22, SD22E SD22D
613-1	154-61-21114	管 tube	1
2	154-61-21254	管 tube	1
3	07000-13048	O型圈 o-ring	2
4	01010-51245	螺栓 bolt	8
5	01602-21236	弹簧垫圈 washer, spring	8
6	154-61-24280	垫板 plate	1
7	07283-23442	卡箍 clip	2
8	01599-01011	螺帽 nut	4
9	01643-31032	垫圈 washer	4
10	07118-01017	软管 hose	2
11	07000-13032	O型圈 o-ring	4
12	07371-31049	拼合凸缘 flange, split	8
13	07472-21035	螺栓 bolt	16
14	01602-21030	弹簧垫圈 washer, spring	16
19	195-61-16170	卡箍 clamp	2
20	01010-51280	螺栓 bolt	2
21	01602-21236	弹簧垫圈 washer, spring	2
22	154-61-24142	管 tube	1
23	154-61-24162	托架 bracket	1
24	01010-51225	螺栓 bolt	4
25	01602-21236	弹簧垫圈 washer, spring	4
26	01010-51225	螺栓 bolt	3
27	01602-21236	弹簧垫圈 washer, spring	3

第 614 图

液压管路（自箱至升降缸）（2/2）

FIG. 614 HYDRAULIC PIPING (TANK TO LIFT CYLINDER)

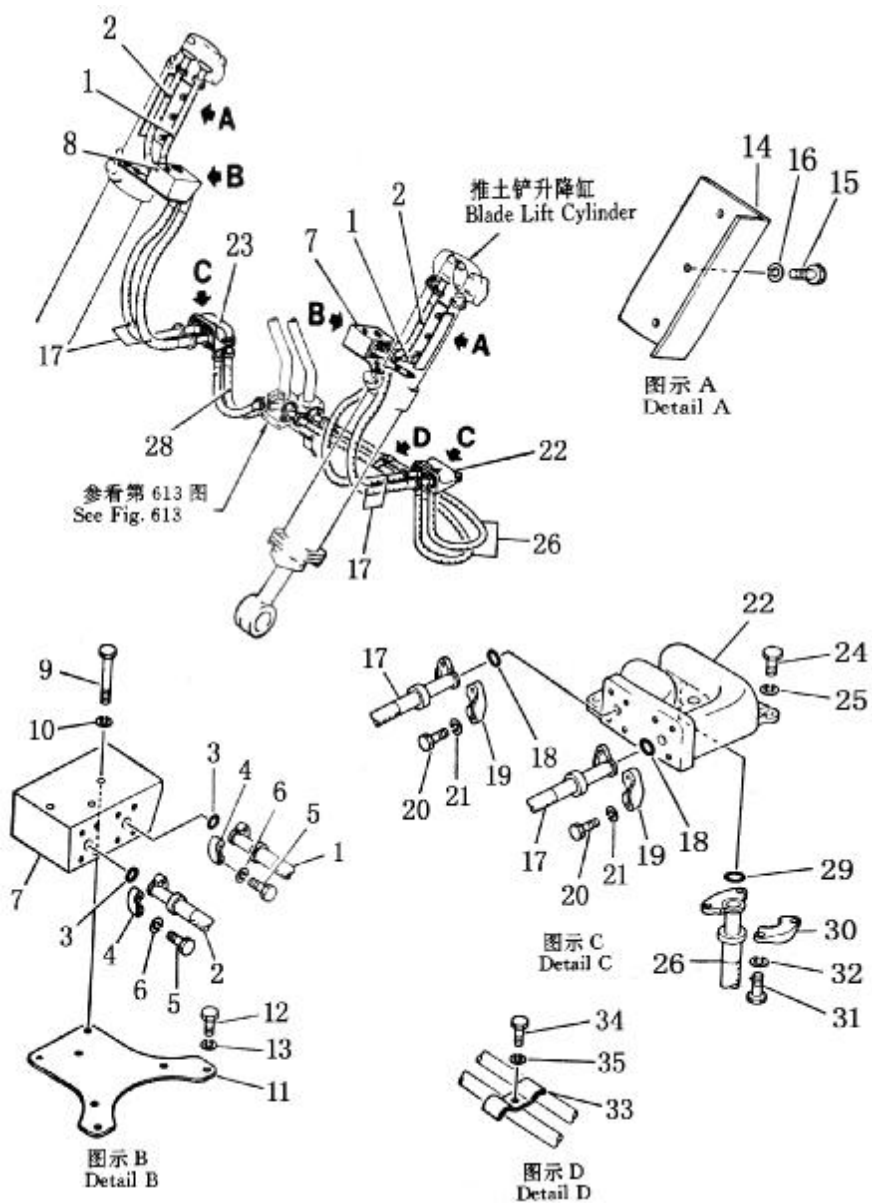

液压管路（自箱至升降缸）（2/2）

HYDRAULIC PIPING（TANK TO LIFT CYLINDER）

序号 Index No.	件号 Part No.	名称 Description	数量 Q' ty	
			SD22	SD22E SD22D
614-1	154-61-21740	软管 hose	2	
	23Y-62E-02000	软管 hose		2
2	154-61-21790	软管 hose	2	
	23Y-62E-01000	软管 hose		2
3	07000-13025	O型圈 o-ring	8	8
4	07371-20638	拼合凸缘 flange, split	16	16
5	07372-20830	螺栓 bolt	32	32
6	01602-20825	弹簧垫圈 washer, spring	32	32
7	154-61-21770	歧管（左） manifold L.H.	1	1
8	154-61-21780	歧管（右） manifold R.H.	1	1
9	01010-51290	螺栓 bolt	6	6
10	01602-21236	弹簧垫圈 washer, spring	6	6
11	154-61-21760	托架 bracket	2	2
12	01010-51230	螺栓 bolt	8	8
13	01602-21236	弹簧垫圈 washer, spring	8	8
14	154-61-21751	护板 protector	2	
	23Y-62E-00006	护板 protector		2
15	01010-51225	螺栓 bolt	4	4
16	01602-21236	弹簧垫圈 washer, spring	4	4
17	07114-00609	软管 hose	4	4
18	07000-13025	O型圈 o-ring	8	8
19	07371-30638	拼合凸缘 flange, split	16	16
20	07372-20380	螺栓 bolt	32	32
21	01602-20825	弹簧垫圈 washer, spring	32	32
22	154-61-21810	调节楔(左) block, L.H	1	1
23	154-61-21820	调节楔(右) block, R.H	1	1
24	01010-51235	螺栓 bolt	4	4
25	01602-21236	弹簧垫圈 washer, spring	4	4
26	07119-00611	软管（左） hose, L.H.	2	2
27	07118-00606	软管（右） hose, R.H.	1	1
28	07118-00608	软管（右） hose, R.H.	1	1
29	07000-13025	O型圈 o-ring	8	8
30	07371-20638	拼合凸缘 flange, split	16	16
31	07372-20830	螺栓 bolt	32	32
32	01602-20825	弹簧垫圈 washer, spring	32	32
33	150-19-25130	卡箍 clamp	1	1
34	01010-51225	螺栓 bolt	1	1
35	01602-21236	弹簧垫圈 washer, spring	1	1

第 615 图 液压管路(1/2) (SD22S 用)
 FIG. 615 HYDRAULIC PIPING (For SD22S)

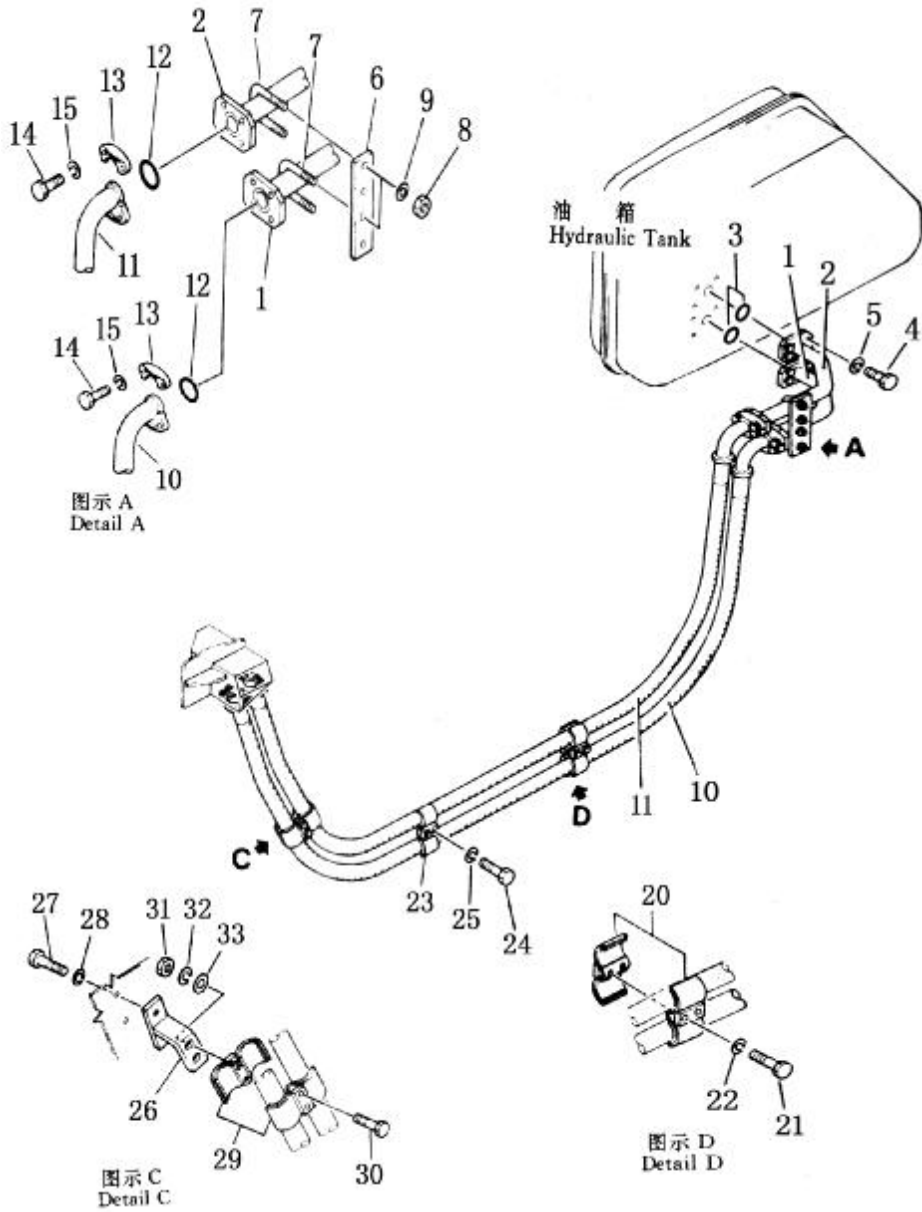

液压管路(1/2) (SD22S 用)
HYDRAULIC PIPING (For SD22S)

序号 Index No.	件 号 Part No.	名 称 Description	数量 Q' ty
			SD22S
615-1	154-61-21114	管 tube	1
2	154-61-21254	管 tube	1
3	07000-13048	O 型圈 o-ring	2
4	01010-51245	螺栓 bolt	8
5	01602-21236	弹簧垫圈 washer, spring	8
6	154-61-24280	垫板 plate	1
7	07283-23442	管卡 clip	2
8	01599-01011	螺母 nut	4
9	01643-31032	加厚垫圈 washer	4
10	07118-01034	软管 hose	1
11	07118-01033	软管 hose	1
12	07000-13032	O 型圈 o-ring	4
13	07371-31049	法兰 flange	8
14	07372-21030	螺栓 bolt	16
15	01602-21030	弹簧垫圈 washer, spring	16
20	195-61-16170	卡箍 clamp	2
21	01010-51280	螺栓 bolt	2
22	01602-21236	弹簧垫圈 washer, spring	2
23	195-61-16170	卡箍 clamp	1
24	01010-51250	螺栓 bolt	2
25	01602-21236	弹簧垫圈 washer, spring	2
26	TS220、611、3	托架 bracket	1
27	01010-51240	螺栓 bolt	2
28	01602-21236	弹簧垫圈 washer, spring	2
29	195-61-16170	卡箍 clamp	2
30	01010-51290	螺栓 bolt	2
31	01580-01210	螺母 nut	2
32	01602-21236	弹簧垫圈 washer, spring	2
33	01643-31232	加厚垫圈 washer	2

第 616 图 液压管路(2/2) (SD22S 用)
FIG. 616 HYDRAULIC PIPING (For SD22S)

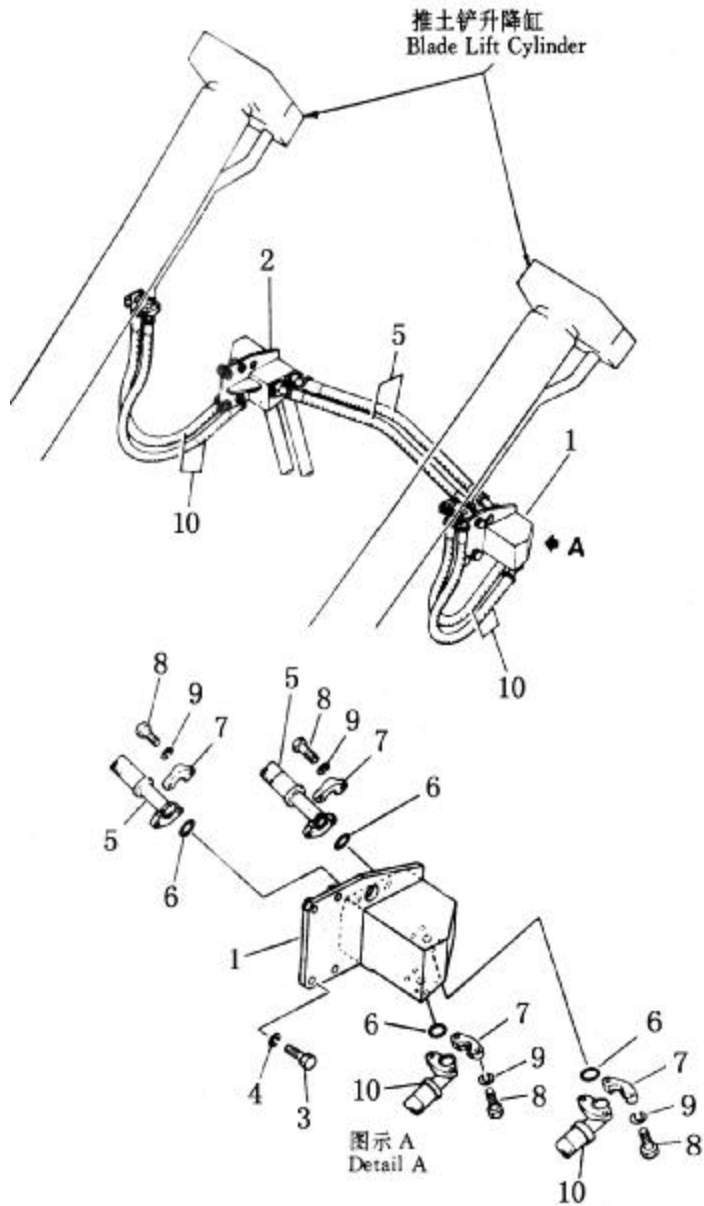

液压管路(2/2) (SD22S 用)
HYDRAULIC PIPING (For SD22S)

序号 Index No.	件 号 Part No.	名 称 Description	数量 Q' ty
			SD22S
616-1	TS220、611、1	左管座 seat, left	1
2	TS220、611、2	右管座 seat, right	1
3	01010-51245	螺栓 bolt	8
4	01602-21236	弹簧垫圈 washer, spring	8
5	07119-00610	软管 hose	2
6	07000-13025	O 型圈 o-ring	12
7	07371-30638	法兰 flange	24
8	07372-20830	螺栓 bolt	48
9	01602-20825	弹簧垫圈 washer, spring	48
10	07118-20610	软管 hose	4

第 617 图 液压管路（自箱至倾斜缸）（1/2）
 FIG. 617 HYDRAULIC PIPING (TANK TO TILT CYLINDER)

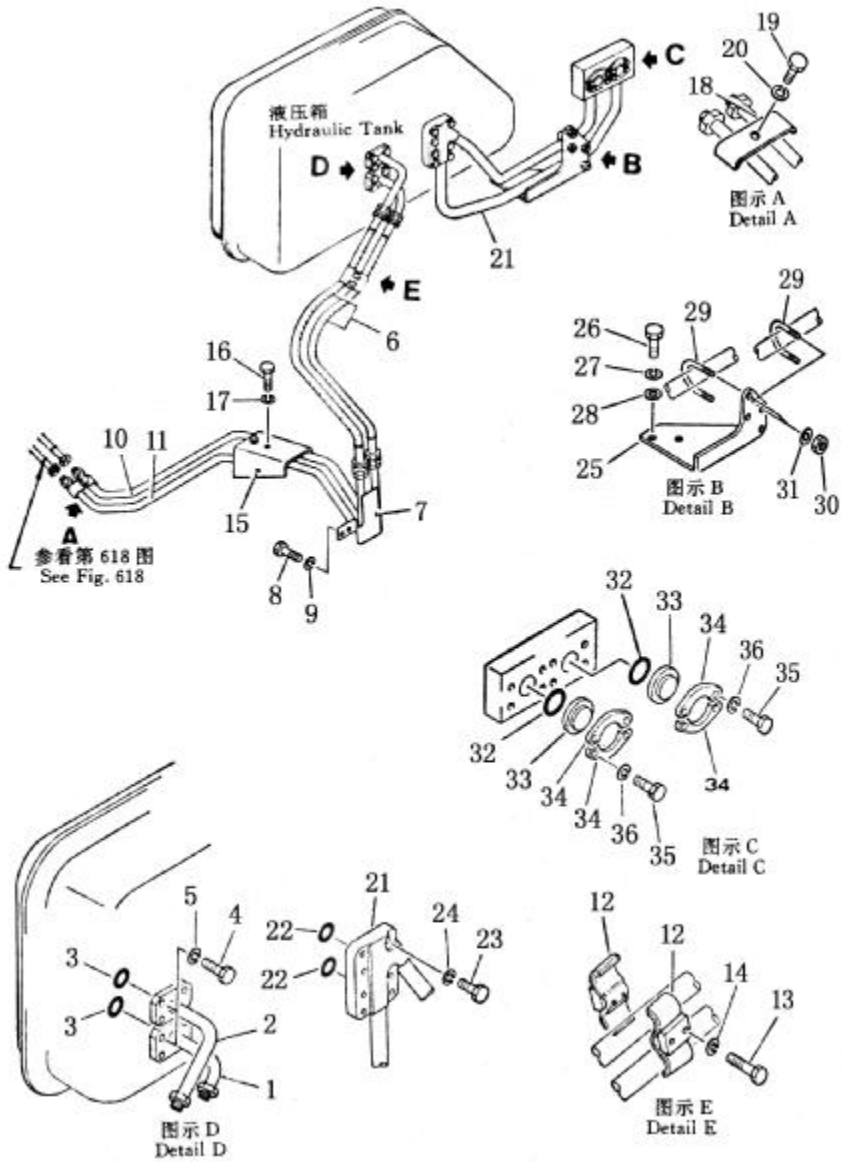

液压管路（自箱至倾斜缸）（1/2）

HYDRAULIC PIPING（TANK TO TILT CYLINDER）

序号 Index No.	件号 Part No.	名称 Description	数量 Q' ty	
			SD22	SD22E SD22D
617-1	154-920-2111	管 tube	1	1
2	154-920-2121	管 tube	1	1
3	07000-13048	O型圈 o-ring	2	2
4	01010-51245	螺栓 bolt	8	8
5	01602-21236	弹簧垫圈 washer, spring	8	8
6	07108-20412	软管 hose	2	2
7	154-920-2143	管 tube	1	1
8	01010-51235	螺栓 bolt	2	2
9	01643-31232	垫圈 washer	2	2
10	154-920-2230	管 tube	1	
	23Y-63E-20000	管 tube		1
11	154-920-2240	管 tube	1	
	23Y-63E-10000	管 tube		1
12	175-914-2270	卡箍 clamp	2	2
13	01010-51230	螺栓 bolt	2	2
14	01602-21030	弹簧垫圈 washer, spring	2	2
15	154-920-2182	托架 bracket	1	1
16	01010-51230	螺栓 bolt	2	2
17	01602-21236	弹簧垫圈 washer, spring	2	2
18	176-62-13270	垫板 plate	1	1
19	01010-51225	螺栓 bolt	1	1
20	01643-31232	垫圈 washer	1	1
21	154-78-32161	管 tube	1	1
22	07000-13048	O型圈 o-ring	2	2
23	01010-51270	螺栓 bolt	7	7
24	01602-21236	弹簧垫圈 washer, spring	7	7
25	154-78-32210	托架 bracket	1	1
26	01010-51240	螺栓 bolt	2	2
27	01602-21236	弹簧垫圈 washer, spring	2	2
28	01643-31232	垫圈 washer	2	2
29	07283-23442	卡箍 clip	2	2
30	01599-01011	螺帽 nut	4	4
31	01643-31032	垫圈 washer	4	4
32	07000-13038	O型圈 O-ring	2	2
33	07378-11000	无孔盖 head, blank	2	2
34	07371-31049	开口法兰 flange, split	4	4
35	07372-21030	螺栓 bolt	8	8
36	01602-21030	垫圈 washer	8	8

第 618 图 液压管路（自箱至倾斜缸）（2/2）
 FIG. 618 HYDRAULIC PIPING (TANK TO TILT CYLINDER)

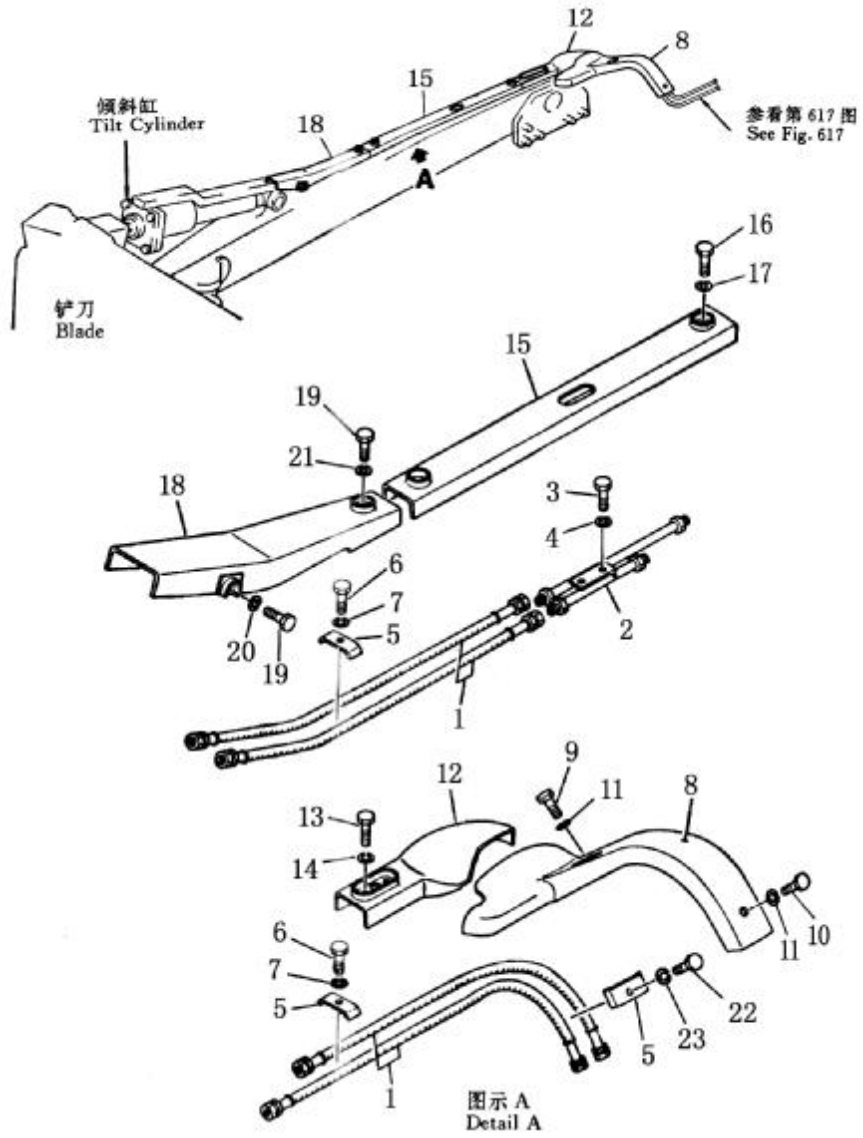

液压管路（自箱至液压缸）(2/2)
HYDRAULIC PIPING（TANK TO TILT CYLINDER）

序号 Index No.	件号 Part No.	名称 Description	数量 Q' ty	
			SD22	SD22E SD22D
618-1	07113-00411	软管 hose	4	4
2	154-71-31450	管 tube	1	1
3	01010-51430	螺栓 bolt	2	2
4	01641-31445	垫圈 washer	2	2
5	154-71-31460	卡箍 clamp	3	3
6	01010-51430	螺栓 bolt	21	21
7	01641-31445	垫圈 washer	21	21
8	154-71-31430	盖 cover	1	1
9	01010-51255	螺栓 bolt	1	1
10	01010-51240	螺栓 bolt	1	1
11	01643-31232	垫圈 washer	2	2
12	154-71-31440	盖 cover	1	
	23Y-63E-00001	盖 cover		1
13	01010-51430	螺栓 bolt	3	3
14	01643-31445	垫圈 washer	3	3
15	154-71-31383	盖 cover	1	1
16	01010-51430	螺栓 bolt	2	2
17	195-71-32220	垫圈 washer	2	2
18	154-71-31394	盖 cover	1	1
19	01010-51430	螺栓 bolt	3	3
20	01643-31445	垫圈 washer	21	21
21	195-71-32220	垫圈 washer	1	1
22	01010-51230	螺栓 bolt	1	1
23	01602-21236	垫圈 washer	1	1

第 619 图 液压管路(1/2) (SD22S 用)
 FIG. 619 HYDRAULIC PIPING (For SD22S)

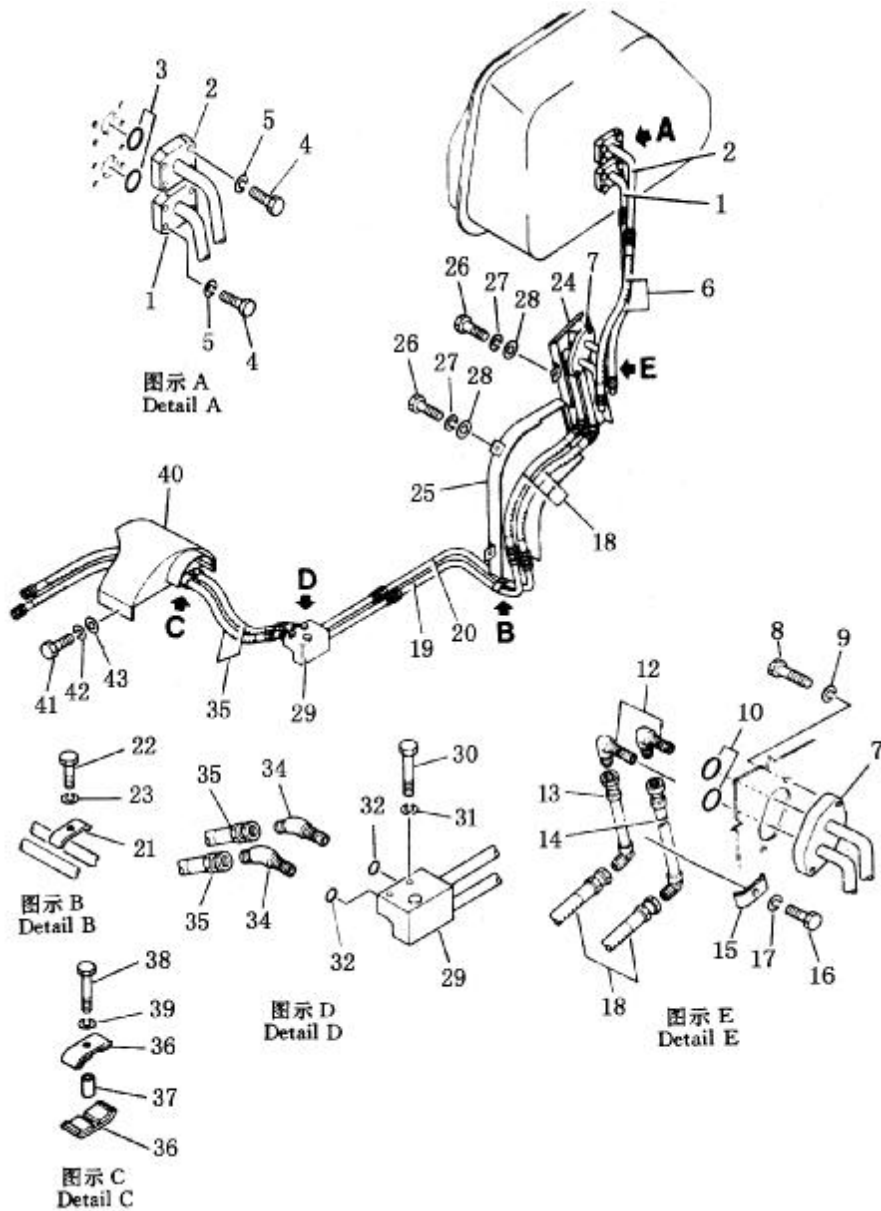

液 压 管 路(1/2) (SD22S 用)
HYDRAULIC PIPING (For SD22S)

序号 Index No.	件 号 Part No.	名 称 Description	数 量 Q' ty
			SD22S
619-1	154-920-2111	管 tube	1
2	154-920-2121	管 tube	1
3	07000-13048	O 型圈 O-ring	2
4	01010-51245	螺栓 bolt	8
5	01602-21236	弹簧垫圈 washer, spring	8
6	07113-00406	软管 hose	2
7	TS220.612.5	管 tube	1
8	01010-51435	螺栓 bolt	2
9	01602-21442	弹簧垫圈 washer, spring	2
10	07002-02034	O 型圈 O-ring	2
12	TS220.612.10	管接头 elbow	2
13	TS220.612.3	管 tube	1
14	TS220.612.4	管 tube	1
15	176-62-13270	卡箍 clamp	1
16	01010-51025	螺栓 bolt	1
17	01602-21030	弹簧垫圈 washer, spring	1
18	07113-00406	软管 hose	2
19	TS220.612.2	管 tube	1
20	TS220.612.1	管 tube	1
21	TS220.612-1	夹子 clamp	1
22	01010-51430	螺栓 bolt	1
23	01602-21442	弹簧垫圈 washer, spring	1
24	TS220.612.6	盖 cover	1
25	TS220.612.7	护盖 cover	1
26	01010-51435	螺栓 bolt	6
27	01602-21442	弹簧垫圈 washer, spring	6
28	01643-31445	垫圈 washer	6
29	TS220.612.8	管 tube	1

液 压 管 路 (1/2) (SD22S 用)
HYDRAULIC PIPING (For SD22S)

序号 Index No.	件 号 Part No.	名 称 Description	数量 Q' ty
			SD22S
619-30	01010-51260	螺栓 bolt	2
31	01602-21236	管 tube	2
32	07002-02034	O 型圈 O-ring	2
34	TS220. 612. 9	弯管接头 elbow	2
35	07013-00412	软管 hose	2
36	154-71-31460	夹子 clamp	2
37	TS220. 612-3	管 tube	1
38	01010-51480	螺栓 bolt	1
39	01602-21442	弹簧垫圈 washer, spring	1
40	TS220. 612. 11	盖 cover	1
41	01010-51440	螺栓 bolt	4
42	01602-21442	弹簧垫圈 washer, spring	4
43	01643--31445	垫圈 washer	4

第 620 图 液压管路 (2/2) (SD22S 用)
FIG. 620 HYDRAULIC PIPING (For SD22S)

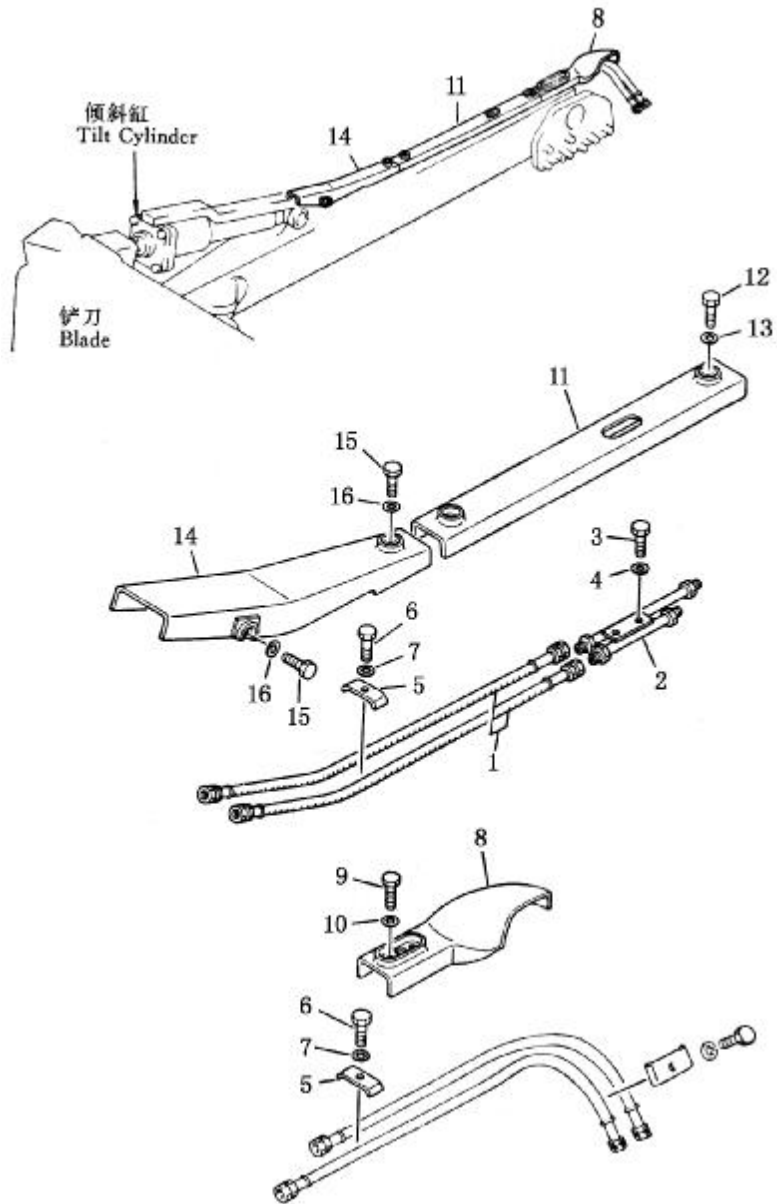

液 压 管 路 (2/2) (SD22S 用)
HYDRAULIC PIPING (For SD22S)

序号 Index No.	件 号 Part No.	名 称 Description	数 量 Q'ty
			SD22S
620-1	07113-00412	软管 hose	4
2	TS220. 71. 7	管接头合件 tube joint ass' y	1
3	01010-51430	螺栓 bolt	2
4	01643-31445	加厚垫圈 washer	2
5	154-71-31460	夹 clamp	2
6	01010-51430	螺栓 bolt	2
7	01643--31445	加厚垫圈 washer	2
8	154-71-31440	盖 cover	1
9	01010-51430	螺栓 bolt	3
10	01643-31445	加厚垫圈 washer	3
11	TS220. 71. 6	中罩 cover, middle	1
12	01010-51430	螺栓 bolt	2
13	195-71-32220	垫圈 washer	2
14	TS220. 71. 5	前罩 cover, front	1
15	01010-51430	螺栓 bolt	3
16	195-71-32220	垫圈 washer	3

第 621 图 倾斜及松土器操纵随动阀
FIG. 621 TILT AND RIPPER CONTROL SERVO VALVE

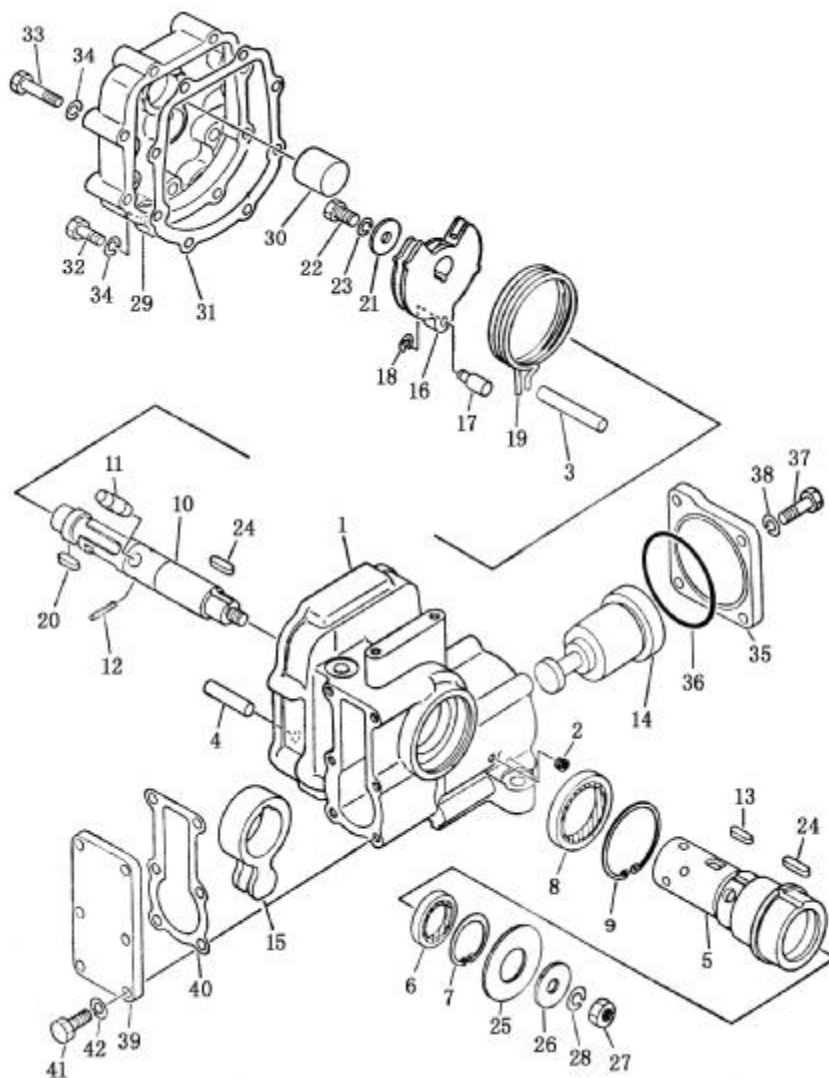

倾斜及松土器操纵随动阀
TILT AND RIPPER CONTROL SERVO VALVE

序号 Index No.	件号 Part No.	名称 Description	数量 Q' ty
621-1、5、 10、14	702-12-14000	随动阀总成（供铲刀倾斜及松土器控制用） servo valve ass' y, for blade tilt and ripper control	2
2	07043-00108	螺塞 plug	2
3	702-12-12140	销 pin	1
4	702-12-12150	销 pin	1
6	702-12-12390	油封 sesl, oil	1
7	04065-04018	开口环 ring, snap	1
8	702-12-12410	油封 sesl, oil	1
9	04065-06020	开口环 ring, snap	1
11	702-12-12180	销 pin	1
12	04025-00316	弹簧销 pin, spring	1
13	04000-00520	键 key	1
15	702-12-12210	杠杆 lever	1
16	702-12-12451	棘爪 detent	1
17	702-12-12230	销 pin	1
18	702-12-12240	开口环 ring, snap	1
19	702-12-12251	弹簧 spring	1
20	04000-00515	键 key	1
21	702-12-12420	垫圈 washer	1
22	01010-50816	螺栓 bolt	1
23	01602-20825	弹簧垫圈 washer, spring	1
24	04000-00520	键 key	2
25	702-12-12280	垫圈 washer	1
26	702-12-12270	垫圈 washer	1
27	01580-11008	螺帽 nut	1
28	01602-21030	弹簧垫圈 washer, spring	1
29	702-12-13220	盖 cover	1

倾斜及松土器操纵随动阀
TILT AND RIPPER CONTROL SERVO VALVE

序号 Index No.	件 号 Part No.	名 称 Description	数 量 Q' ty
621-30	702-12-13210	销 pin	1
31	702-12-13140	填密垫 gasket	1
32	01010-50835	螺栓 bolt	2
33	01010-50845	螺栓 bolt	6
34	01602-20825	弹簧垫圈 washer, spring	8
35	702-12-13160	盖 cover	1
36	07000-22070	O 型圈 O-ring	1
37	01010-50825	螺栓 bolt	4
38	01602-20825	弹簧垫圈 washer, spring	4
39	702-12-13130	盖 cover	1
40	702-12-13150	填密垫 gasket	1
41	01010-50825	螺栓 bolt	6
42	01602-20825	弹簧垫圈 washer, spring	6

第 622 图 随动阀管路
FIG. 622 SERVO VALVE PIPING

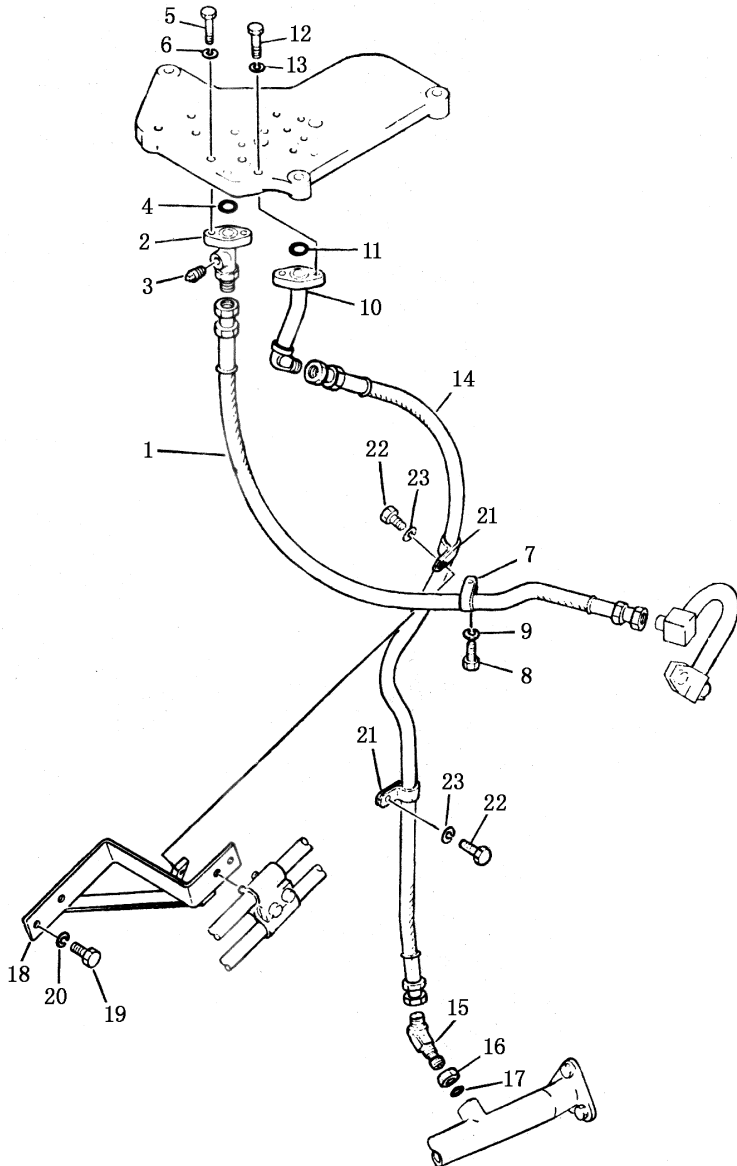

随动阀管路
SERVO VALVE PIPING

序号 Index No.	件号 Part No.	名称 Description	数量 Q' ty
622-1	07102-20410	软管 hose	1
2	154-61-17150	管 tube	1
3	07042-20108	螺塞 plug	1
4	07000-03025	O型圈 O-ring	1
5	01010-51045	螺栓 bolt	2
6	01602-21030	弹簧垫圈 washer, spring	2
7	08035-02508	卡箍 clip	1
8	01011-51016	螺栓 bolt	1
9	01602-21030	弹簧垫圈 washer, spring	1
10	154-61-17131	管 tube	1
11	07000-03025	O型圈 O-ring	1
12	01010-51045	螺栓 bolt	1
13	01602-21030	弹簧垫圈 washer, spring	1
14	07102-20412	软管 hose	1
15	07234-10422	弯头 elbow	1
16	07239-12009	螺帽 nut	1
17	07002-02034	O型圈 O-ring	1
18	154-61-17140	托架 bracket	2
19	01010-51225	螺栓 bolt	2
20	01602-21236	弹簧垫圈 washer, spring	2
21	08035-02508	卡箍 clip	2
22	01010-51016	螺栓 bolt	2
23	01602-21030	弹簧垫圈 washer, spring	

第 623 图 操纵杆托架及阀座
 FIG. 623 CONTROL LEVER BRACKET AND VALVE SEAT

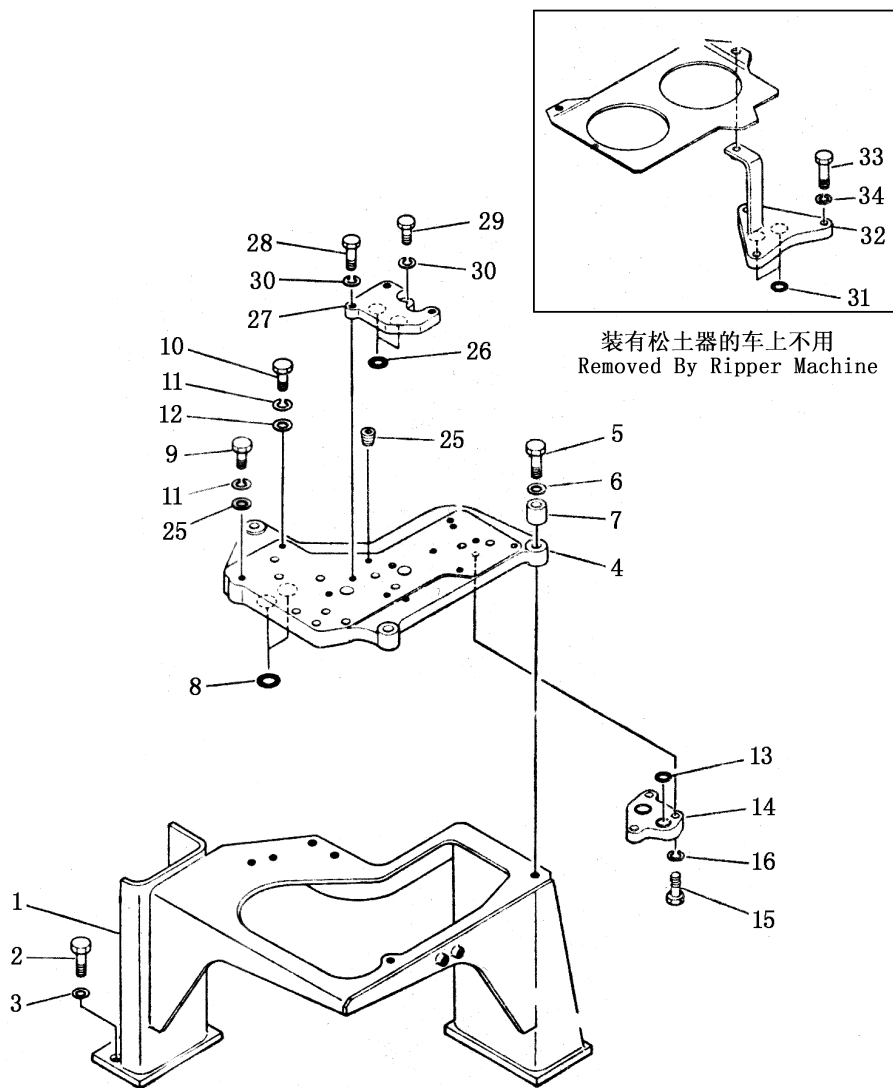

操纵杆托架及阀座

CONTROL LEVER BRACKET AND VALVE SEAT

序号 Index No.	件 号 Part No.	名 称 Description	数 量 Q' ty
623-1	154-61-16840	托架 bracket	1
2	01010-51645	螺栓 bolt	6
3	01643-31645	垫圈 washer	6
4	195-61-21230	阀座 seat, valve	1
5	01010-51480	螺栓 bolt	3
6	01643-31445	垫圈 washer	3
7	198-21-12240	轮壳 boss	3
8	07000-03022	0 型圈 0-ring	2
9	01011-51045	螺栓 bolt	1
10	01010-51040	螺栓 bolt	2
11	01602-21030	垫圈 washer	3
12	01643-31032	垫圈 washer	3
13	07000-03022	0 型圈 0-ring	2
14	195-61-21430	垫板 plate	1
15	01010-51035	螺栓 bolt	3
16	01602-21030	垫圈 washer	3
25	07043-00617	螺塞 plug	1
26	07000-03022	0 型圈 0-ring	2
27	154-61-16680	垫板 plate	1
28	01010-51035	螺栓 bolt	2
29	01010-51025	螺栓 bolt	1
30	01602-21030	垫圈 washer	3
*31	07000-03022	0 型圈 0-ring	2
*32	195-61-21420	垫板 plate	1
*33	01010-51035	螺栓 bolt	3
*34	01602-21030	垫圈 washer	3

注：带*标记的零件在装有松土器的车上不用。

第 624 图 铲刀操纵杆
 FIG. 624 BLADE CONTROL LEVER

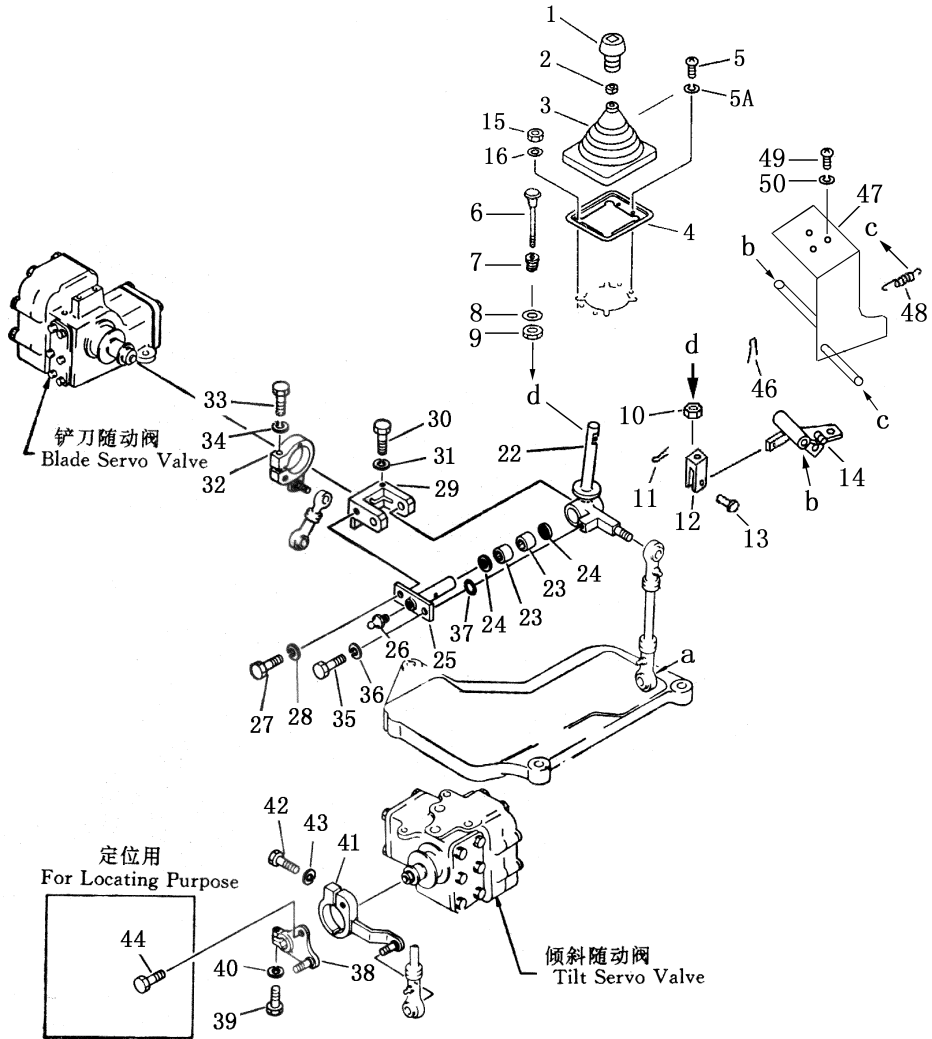

铲刀操纵杆
BLADE CONTROL LEVER

序号 Index No.	件号 Part No.	名称 Description	数量 Q' ty
624-1	16Y-86C-11000	手柄 knob	1
2	195-43-44220	螺母 nut	1
3	195-61-45140	护罩 boot	1
4	23Y-86B-00002	座 base	1
5	01220-40508	螺母 nut	4
5A	01601-20513	垫圈 washer	4
6	23Y-86B-02000	按钮 button	1
7	175-61-31750	凸块 boss	1
8	01640-22232	垫圈 washer	1
9	195-61-45230	螺母 nut	1
10	01580-10806	螺母 nut	1
11	04050-13018	开口销 pin, cotter	1
12	04211-20844	叉口板 yoke	1
13	04205-10822	销轴 pin, shaft	1
14	23Y-86B-04000	摇臂 lever	1
15	01580-10806	螺帽 nut	1
16	01643-30823	垫圈 washer	1
22	23Y-86B-01000	操纵杆 lever	1
23	06120-02016	滚针轴承 bearing, , needle	1
24	06122-02004	轴承护圈 seal, bearing	1
25	154-61-16471	轴 shaft	1
26	07020-00000	滑脂嘴 fitting, grease	1
27	01010-50820	螺栓 bolt	1
28	01602-20825	垫圈 washer	1
29	154-61-16411	轭 yoke	1
30	01010-50835	螺栓 bolt	1

铲刀操纵杆
BLADE CONTROL LEVER

序号 Index No.	件 号 Part No.	名 称 Description	数 量 Q' ty
624-31	01602-20825	垫圈 washer	1
32	154-61-16481	杠杆 lever	1
33	01010-50840	螺栓 bolt	1
34	01602-20825	垫圈 washer	1
35	01010-50820	螺栓 bolt	1
36	01602-20825	垫圈 washer	1
37	01643-30823	垫圈 washer	1
38	154-61-16611	杠杆 lever	1
39	01010-50830	螺栓 bolt	1
40	01602-20825	垫圈 washer	1
41	154-61-16621	杠杆 lever	1
42	01010-50840	螺栓 bolt	1
43	01602-20825	垫圈 washer	1
*44	01010-50835	螺栓 bolt	2
46	04050-12015	开口销 pin, cotter	1
47	23Y-86B-03000	支架 bracket	1
48	195-61-45290	弹簧 spring	1
49	01010-50816	螺栓 bolt	3
50	01643-30823	垫圈 washer	3

注:带*标记的零件仅在装配时作为定位用,而不是装车时用。

第 625 图 松土器操纵杆
 FIG. 625 RIPPER CONTROL LEVER

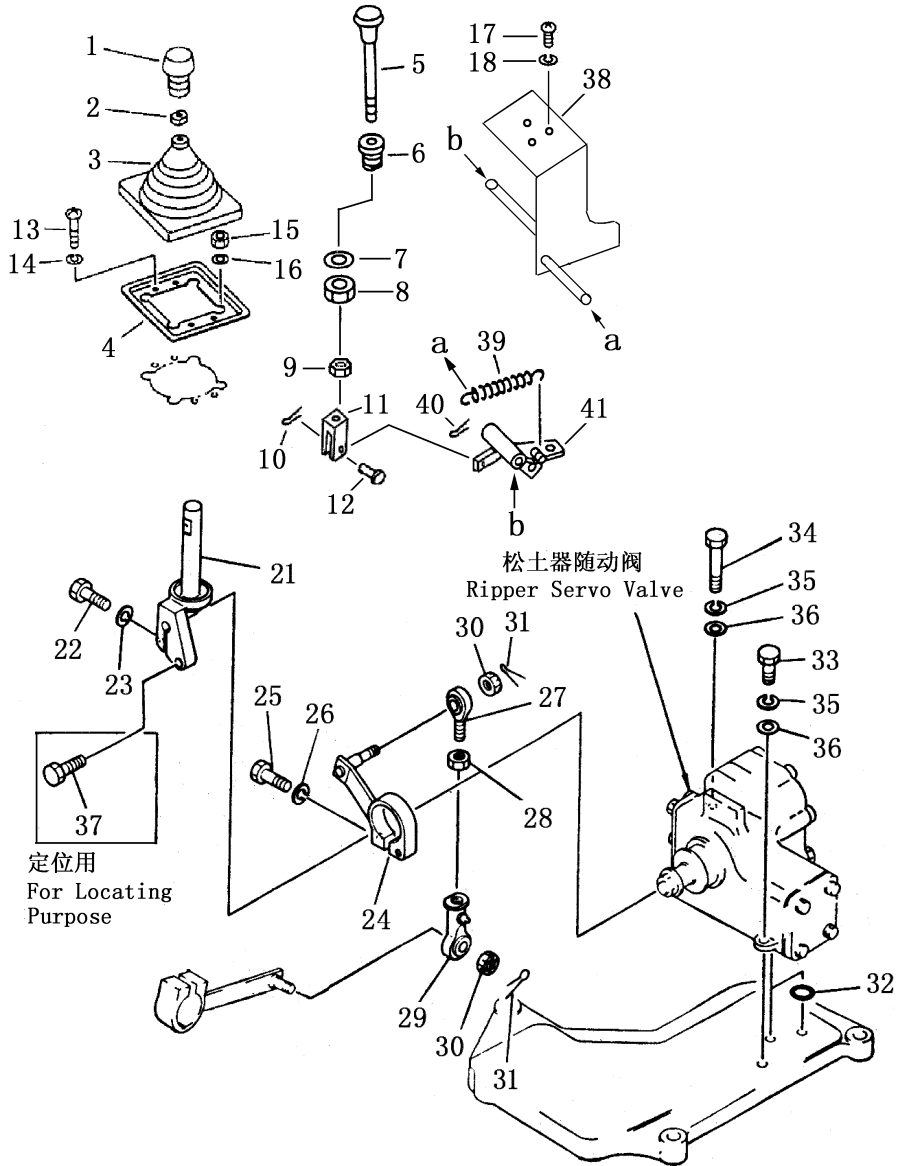

松土器操纵杆
RIPPER CONTROL LEVER

序号 Index No.	件号 Part No.	名称 Description	数量 Q' ty
625-1	16Y-86C-11000	手柄 knob	1
2	195-43-44220	螺母 nut	1
3	195-61-45140	护罩 boot	1
4	23Y-86B-00002	座 base	1
5	23Y-86B-02000	按钮 button	1
6	175-61-31750	凸块 boss	1
7	01640-22232	垫圈 washer	1
8	195-61-45230	螺母 nut	1
9	01580-10806	螺母 nut	1
10	04050-13018	开口销 pin, cotter	1
11	04211-20844	叉口板 yoke	1
12	04205-10822	销轴 pin, shaft	1
13	01220-40508	螺母 nut	4
14	01601-20513	垫圈 washer	4
15	01580-10806	螺母 nut	4
16	01643-30823	垫圈 washer	4
17	01010-50816	螺栓 bolt	3
18	01643-30823	弹簧垫圈 washer, spring	3
21	23Y-87B-01000	操纵杆 lever	1
22	01010-50835	螺栓 bolt	1
23	01602-20825	弹簧垫圈 washer, spring	1
24	154-61-16531	杠杆 lever	1
25	01010-50840	螺栓 bolt	1
26	01602-20825	弹簧垫圈 washer, spring	1
27	04252-01269	杆端 end, rod	1
28	01582-11210	螺帽 nut	1
29	04250-51265	杆端 end, rod	1
30	01593-11210	螺帽 nut	2
31	04050-13020	开口销 pin, cotter	2
32	07000-03022	O型圈 O-ring	2
33	01011-51045	螺栓 bolt	1
34	01010-51040	螺栓 bolt	2
35	01602-21030	弹簧垫圈 washer, spring	3
36	01643-31032	垫圈 washer	3
*37	01010-50835	螺栓 bolt	1
38	23Y-86B-03000	支架 bracket	1
39	195-61-45290	弹簧 spring	1
40	04050-12015	开口销 pin, cotter	1
41	23Y-86B-04000	摇臂 lever	1

注:带*标记的零件仅在装配时作为定位用,而不是装车时用。

第 626 图 升降及松土器操纵联动装置
 FIG. 626 LIFT AND RIPPER CONTROL LINKAGE

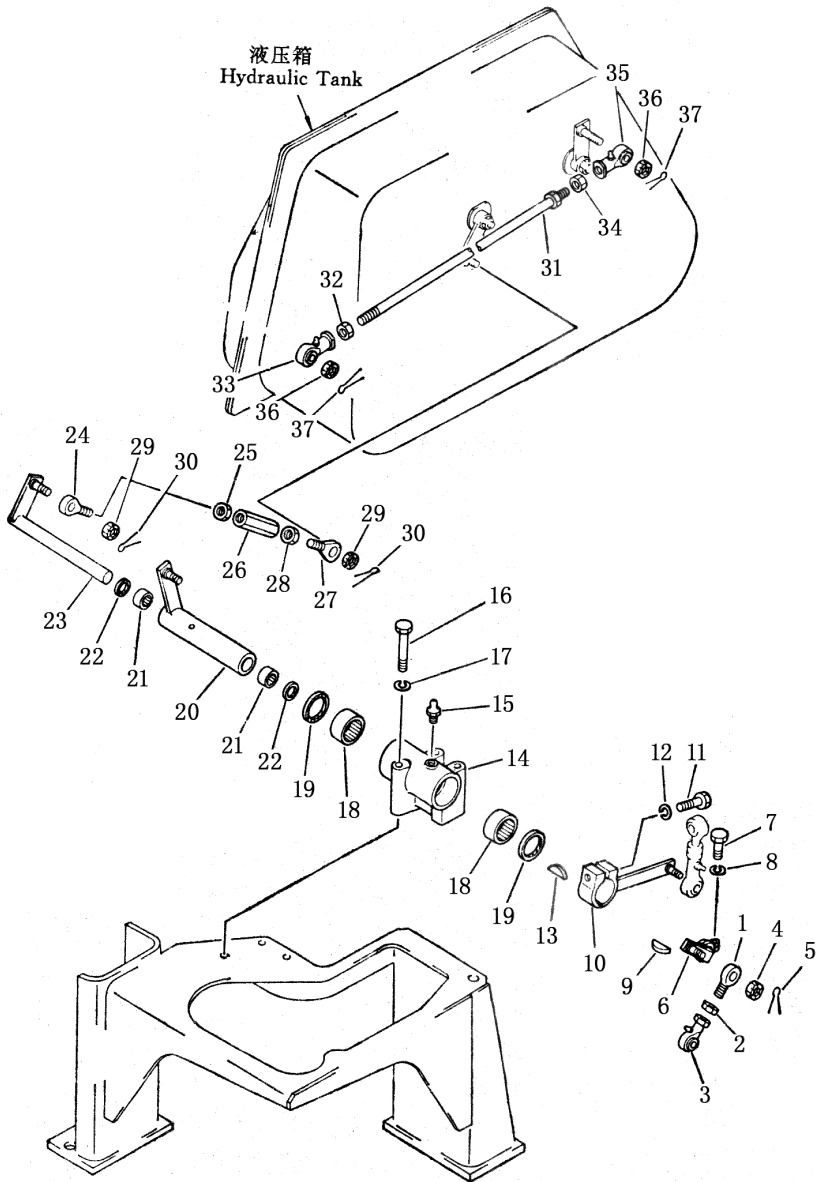

升降及松土器操纵联动装置
LIFT AND RIPPER CONTROL LINKAGE

序号 Index No.	件号 Part No.	名称 Description	数量 Q' ty
626-1	04252-01269	杆端 end, rod	1
2	01582-11210	螺帽 nut	1
3	04250-51265	杆端 end, rod	1
4	01593-11210	螺帽 nut	2
5	04050-13020	开口销 pin, cotter	2
6	154-61-16730	杠杆 lever	1
7	01010-50830	螺栓 bolt	1
8	01602-20825	弹簧垫圈 washer, spring	1
9	04010-00519	键 key	1
10	154-61-16750	杠杆 lever	1
11	01010-50850	螺栓 bolt	1
12	01602-20825	弹簧垫圈 washer, spring	1
13	04010-00519	键 key	1
14	154-61-16660	托架 bracket	1
15	07020-00675	滑油嘴 fitting, grease	1
16	01011-51010	螺栓 bolt	21
17	01602-21030	弹簧垫圈 washer, spring	3
18	06120-04520	滚针轴承 bearing, needle	2
19	06122-04504	轴承护圈 seal, bearing	2
20	154-61-16760	杠杆 lever	1
21	06120-02016	滚针轴承 bearing, needle	2
22	06122-02004	轴承护圈 seal, bearing	2
23	154-61-16740	杠杆 lever	1
24	04252-01269	杆端 end, rod	1
25	01582-11210	螺帽 nut	1
26	23Y-86B-00001	拉线螺丝 turn buckle	1
27	04252-11269	杆端 end, rod	1
28	01508-21207	螺帽 nut	1
29	01593-11210	螺帽 nut	2
30	04050-13020	开口销 pin, cotter	2
31	04248-31240	杆 rod	1
32	01508-21207	螺帽 nut	1
33	04250-71265	杆端 end, rod	1
34	01582-11210	螺帽 nut	1
35	04250-51265	杆端 end, rod	1
36	01593-11210	螺帽 nut	2
37	04050-13020	开口销 pin, cotter	2

第 627 图 倾斜操纵联动装置
 FIG. 627 TILT CONTROL LINKAGE

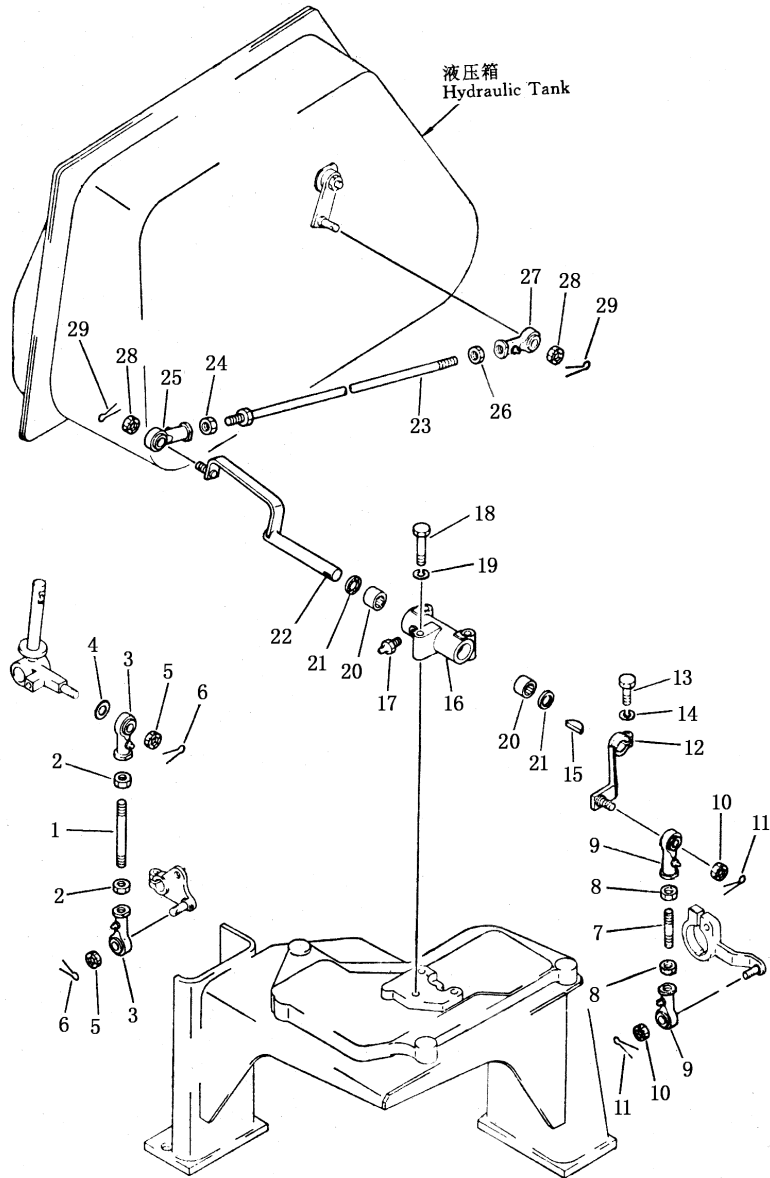

倾斜操纵联动装置
TILT CONTROL LINKAGE

序号 Index No.	件 号 Part No.	名 称 Description	数 量 Q' ty
627-1	04245-41213	杆 rod	1
2	01582-11210	螺栓 bolt	2
3	04250-51265	杆端 end, rod	2
4	04254-01232	衬垫 spacer	1
5	01593-11210	螺帽 nut	2
6	04050-13020	开口销 pin, cotter	2
7	04245-41209	杆 rod	1
8	01582-11210	螺帽 nut	2
9	04250-51265	杆端 end, rod	2
10	01593-11210	螺帽 nut	2
11	04050-13020	开口销 pin, cotter	2
12	154-61-16770	杠杆 lever	1
13	01010-50830	螺栓 bolt	1
14	01602-20825	弹簧垫圈 washer, spring	1
15	04010-00519	键 key	1
16	154-61-16650	托架 bracket	1
17	07020-00000	滑脂嘴 fitting, grease	1
18	01010-51060	螺栓 bolt	3
19	01602-21030	弹簧垫圈 washer, spring	3
20	06120-02016	滚针轴承 bearing, needle	2
21	06122-02004	轴承护圈 seal, bearing	2
22	154-61-16780	杠杆 lever	1
23	04248-31227	杆 rod	1
24	01508-21207	螺帽 nut	1
25	04250-71265	杆端 end, rod	1
26	01593-11210	螺帽 nut	1
27	04250-51265	杆端 end, rod	1
28	04050-13020	开口销 pin, cotter	2
29	01582-11210	螺帽 nut	2

第 628 图 铲刀操纵联动装置
FIG. 628 BLADE CONTROL LINKAGE

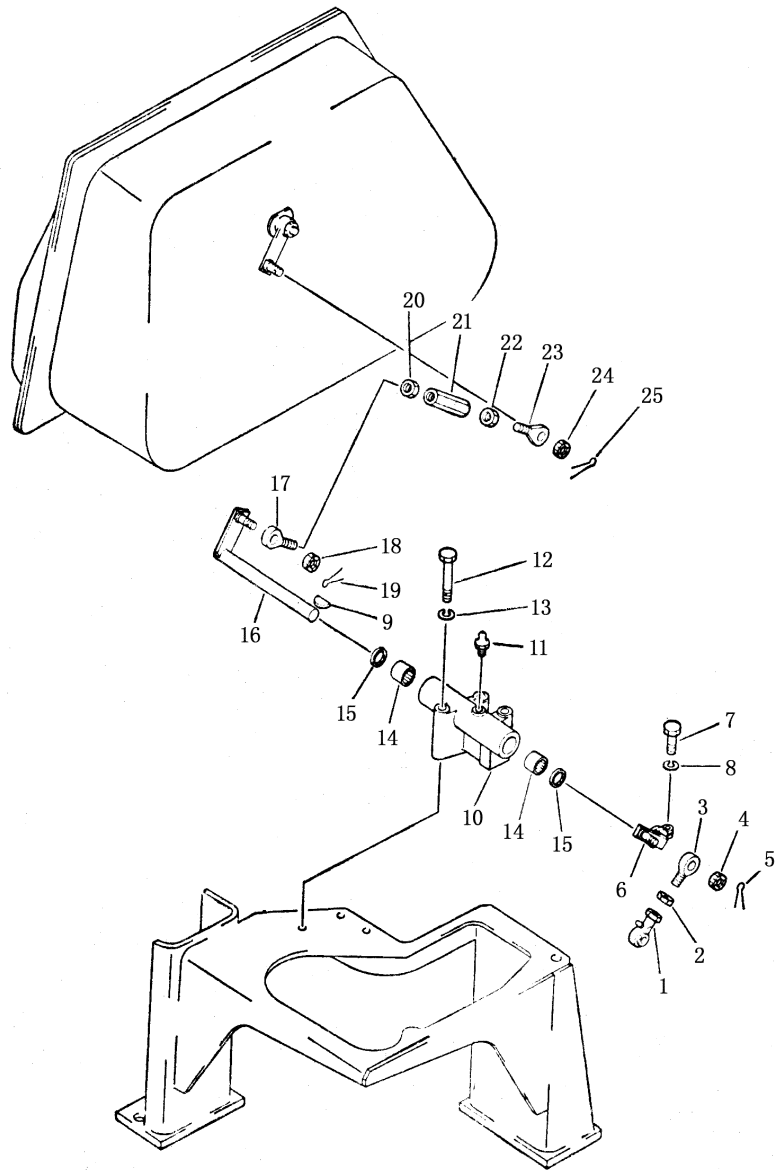

铲刀操纵联动装置
BLADE CONTROL LINKAGE

序号 Index No.	件 号 Part No.	名 称 Description	数量 Q' ty
628-1	04250-51265	杆端 end, rod	1
2	01582-01210	螺帽 nut	1
3	04252-01269	杆端 end, rod	1
4	01593-01210	螺帽 nut	1
5	04050-03020	开口销 pin, cotter	1
6	154-61-16730	杠杆 lever	1
7	01010-50830	螺栓 bolt	1
8	01602-20825	弹簧垫圈 washer, spring	1
9	04010-00519	键 key	1
10	154-61-16670	托架 bracket	1
11	07020-00000	滑脂嘴 fitting, grease	1
12	01011-51010	螺栓 bolt	3
13	01602-21030	弹簧垫圈 washer, spring	3
14	06120-02016	滚针轴承 bearing needle	2
15	06122-02004	轴承护圈 seal, bearing	2
16	154-61-16740	杠杆 lever	1
17	04252-01269	杆端 end, rod	1
18	01593-01210	螺帽 nut	1
19	04050-03020	开口销 pin, cotter	1
20	01582-01210	螺帽 nut	1
21	154-61-16720	拉线螺丝 turn buckle	1
22	01508-11207	螺帽 nut	1
23	04252-11269	杆端 end, rod	1
24	01593-01210	螺帽 nut	1
25	04050-03020	开口销 pin, cotter	1

第 629 图
FIG. 629

升降操纵随动阀
LIFT CONTROL SERVO VALVE

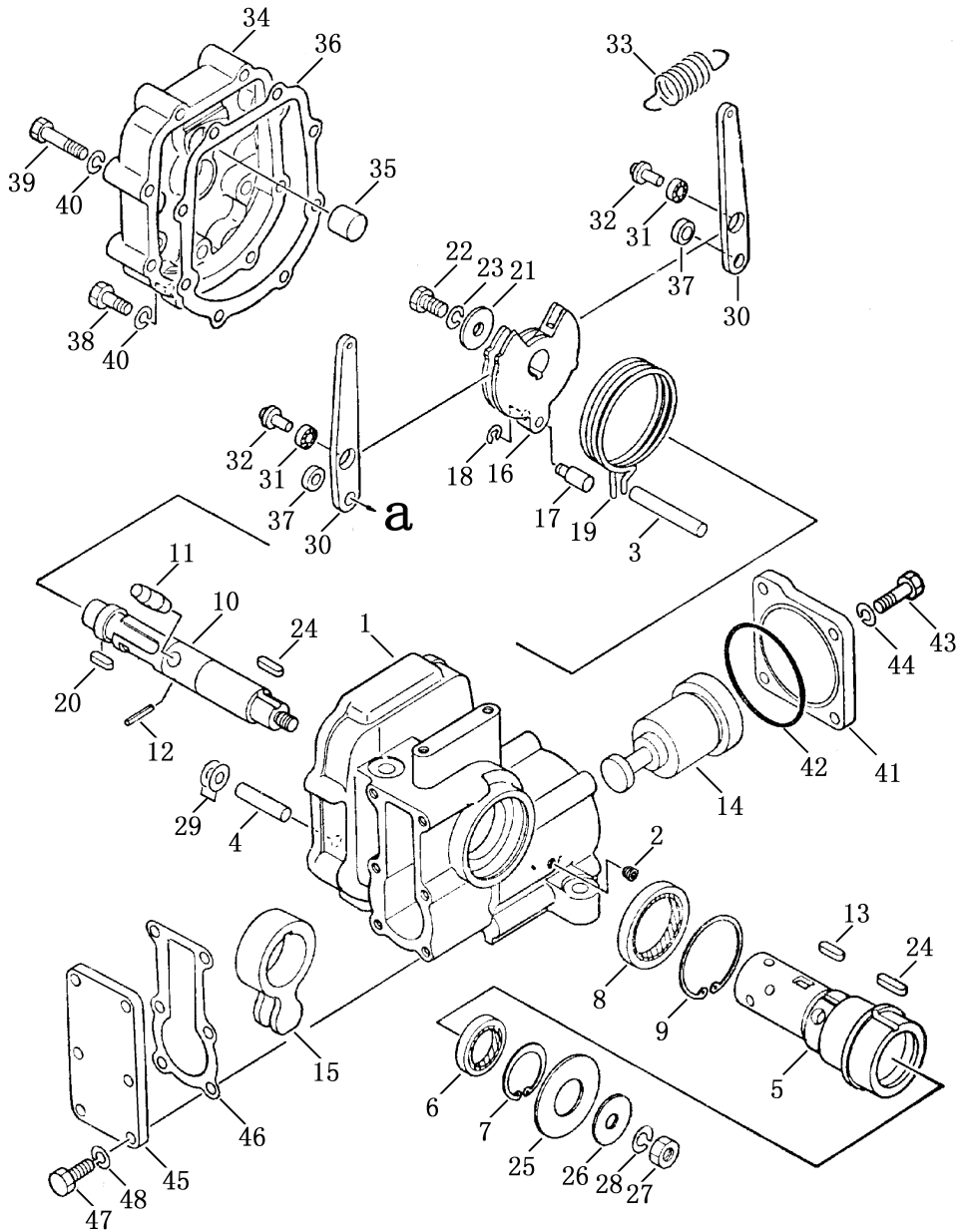

升降操纵随动阀
LIFT CONTROL SERVO VALVE

序号 Index No.	件号 Part No.	名称 Description	数量 Q' ty
629-1、5、 10、14	702-12-13001	随动阀总成 servo valve ass' y (供升降铲刀用) for blade lift	1
2	07043-00108	螺塞 plug	2
3	702-12-12140	销 pin	1
4	702-12-12150	销 pin	1
6	702-12-12390	油封 seal , oil	1
7	04065-04018	开口环 ring , snap	1
8	702-12-12410	油封 seal , oil	1
9	04065-06020	开口环 ring , snap	1
11	702-12-12180	销 pin	1
12	04025-00316	弹簧销 pin , spring	1
13	04000-10520	键 key	1
15	702-12-12210	杠杆 lever	1
16	702-12-12221	棘爪 detent	1
17	702-12-12230	销 pin	1
18	702-12-12240	开口环 ring , snap	1
19	702-12-12251	弹簧 spring	1
20	04000-10515	键 key	1
21	702-12-12420	垫圈 washer	1
22	01010-50816	螺栓 bolt	1
23	01602-20825	垫圈 washer	1
24	04000-10520	键 key	2
25	702-12-12280	垫圈 washer	1
26	702-12-12270	垫圈 washer	1
27	01580-11008	螺帽 nut	1
28	01602-21030	垫圈 washer	1
29	01641-21016	垫圈 washer	4
30	702-12-12291	杠杆 lever	2
31	702-12-12310	轴承 bearing	2
32	702-12-12320	滚子 roller	2
33	702-12-12331	弹簧 spring	1
34	702-12-13120	盖 cover	1
35	702-12-12340	键 key	1
36	702-12-13140	填密垫 gasket	1
37	702-12-12361	衬垫 spacer	2
38	01010-50835	螺栓 bolt	2

升降操纵随动阀
LIFT CONTROL SERVO VALVE

序号 Index No.	件号 Part No.	名称 Description	数量 Q' ty
629-39	01010-50845	螺栓 bolt	6
40	01602-20825	垫圈 washer	8
41	702-12-13160	盖 cover	1
42	07000-22070	O型圈 O-ring	1
43	01010-50825	螺栓 bolt	4
44	01602-20825	垫圈 washer	4
45	702-12-13130	盖 cover	1
46	702-12-13150	填密垫 gasket	1
47	01010-50825	螺栓 bolt	6
48	01602-20825	垫圈 washer	6

工 作 装 置

WORK EQUIPMENT

第 701 图

半 U 型 铲

FIG. 701

BLADE SEMI-U DOZER

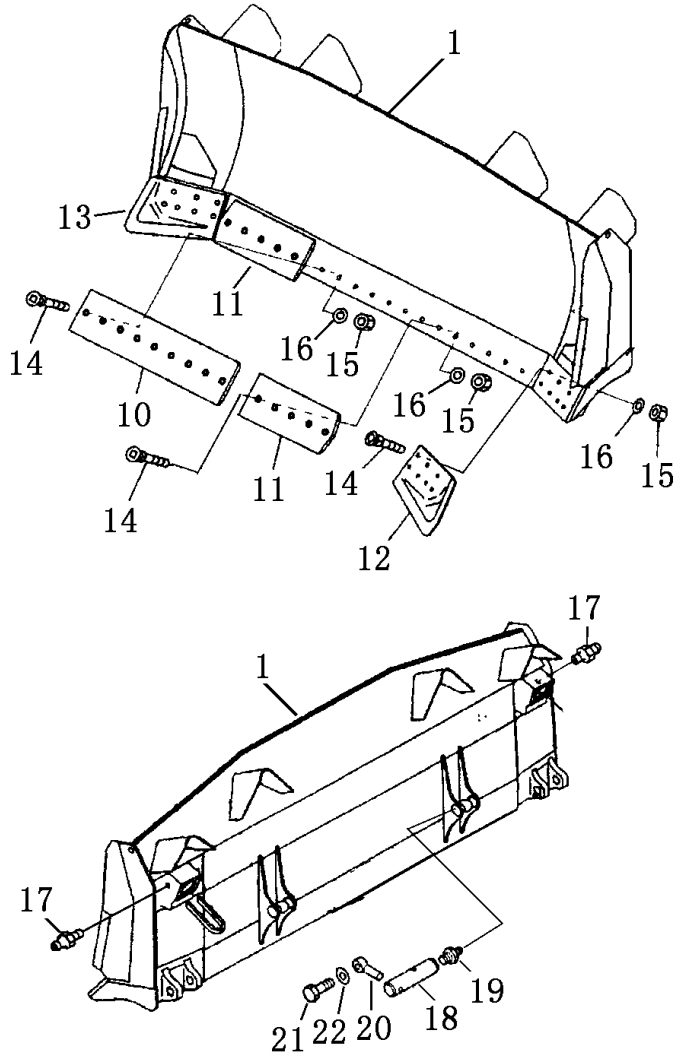

半 U 型 铲
BLADE SEMI-U DOZER

序号 Index No.	件 号 Part No.	名 称 Description	数量 Q'ty
			SD22 SD22E
701-1	23Y-82-01000	半 U 型铲 blade semi-U dozer	1
10	150-70-11314	刀片 cutting edge	1
11	23Y-82-00001	刀片 cutting edge	2
12	175-71-22272	左刀角 bit L.H.	1
13	175-71-22282	右刀角 bit R.H.	1
14	154-70-11143	螺栓 bolt	32
15	154-70-22270	螺母 nut	32
16	01643-21845	加厚垫圈 washer	32
17	07020-01021	接头式压注油杯 fitting grease	2
18	154-71-22511	轴 shaft	2
19	07020-01021	接头式压注油杯 fitting grease	2
20	195-71-11520	销 pin	2
21	01010-51435	螺栓 bolt	2
22	01643-31445	加厚垫圈 washer	2

第 702 图 直 倾 铲
FIG. 702 STRAIGHT TILT BLADE

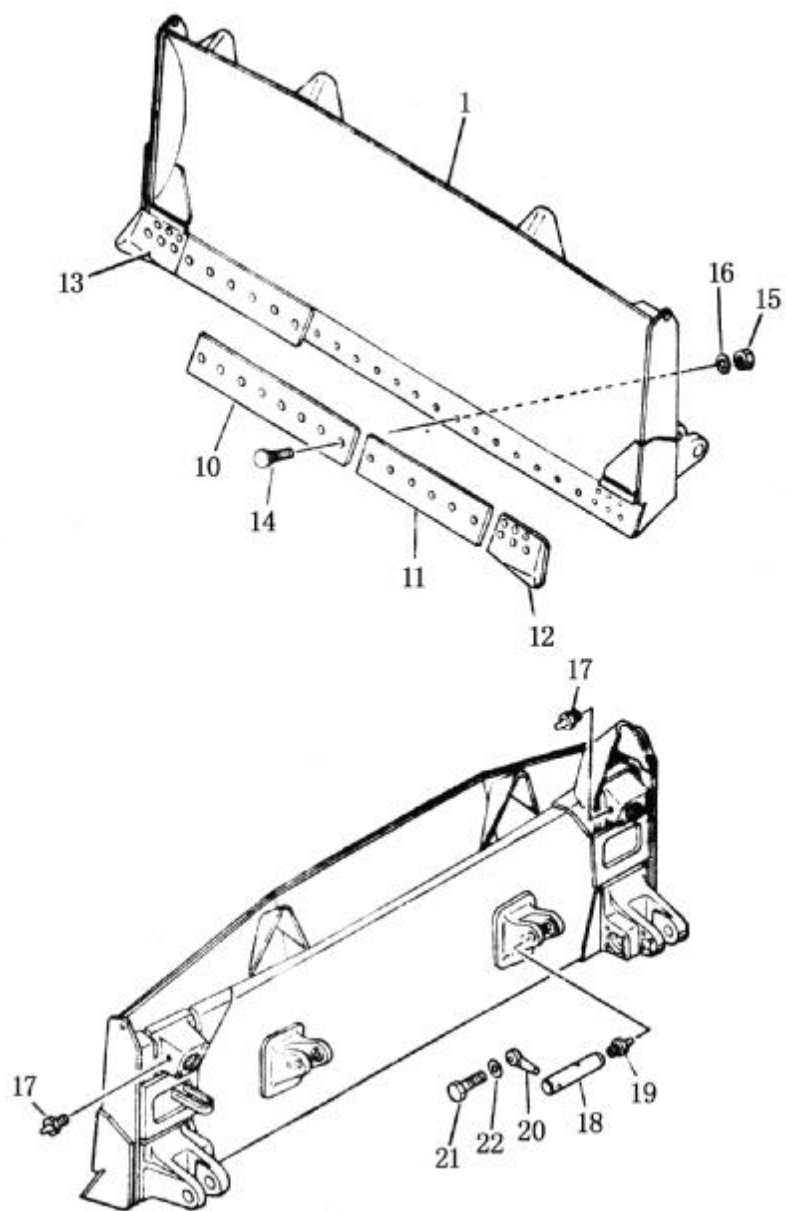

直 倾 铲
STRAIGHT TILT BLADE

序号 Index No.	件 号 Part No.	名 称 Description	数 量 Q' ty	
			SD22 SD22E	SD22D
702-1	154-71-31001	刀头总成 blade, tilt ass' y	1	
	22M-80-10000	刀头总成 blade, tilt ass' y		1
10	150-70-11314	刀片 edge cutting	1	3
11	154-81-11191	刀片 edge cutting	2	1
12	150-70-21356	左刀角 bit, end, l, h	1	1
13	150-70-21346	右刀角 bit, end, r, h	1	1
14	154-70-11143	螺栓 bolt	32	36
15	154-70-22270	螺帽 cap	32	36
16	01643-21845	加厚垫圈 washer	32	36
17	07020-00000	接头式压注油杯 fitting grease	2	2
18	154-7122511	轴 shaft	2	2
19	07020-00000	接头式压注油杯 fitting grease	2	2
20	195-71-11520	销 pin	2	2
21	01010-51435	螺栓 nut	2	2
22	01643-31445	加厚垫圈 washer	2	2

第 703 图 推 杆
 FIG. 703 STRAIGHT TILT FRAME

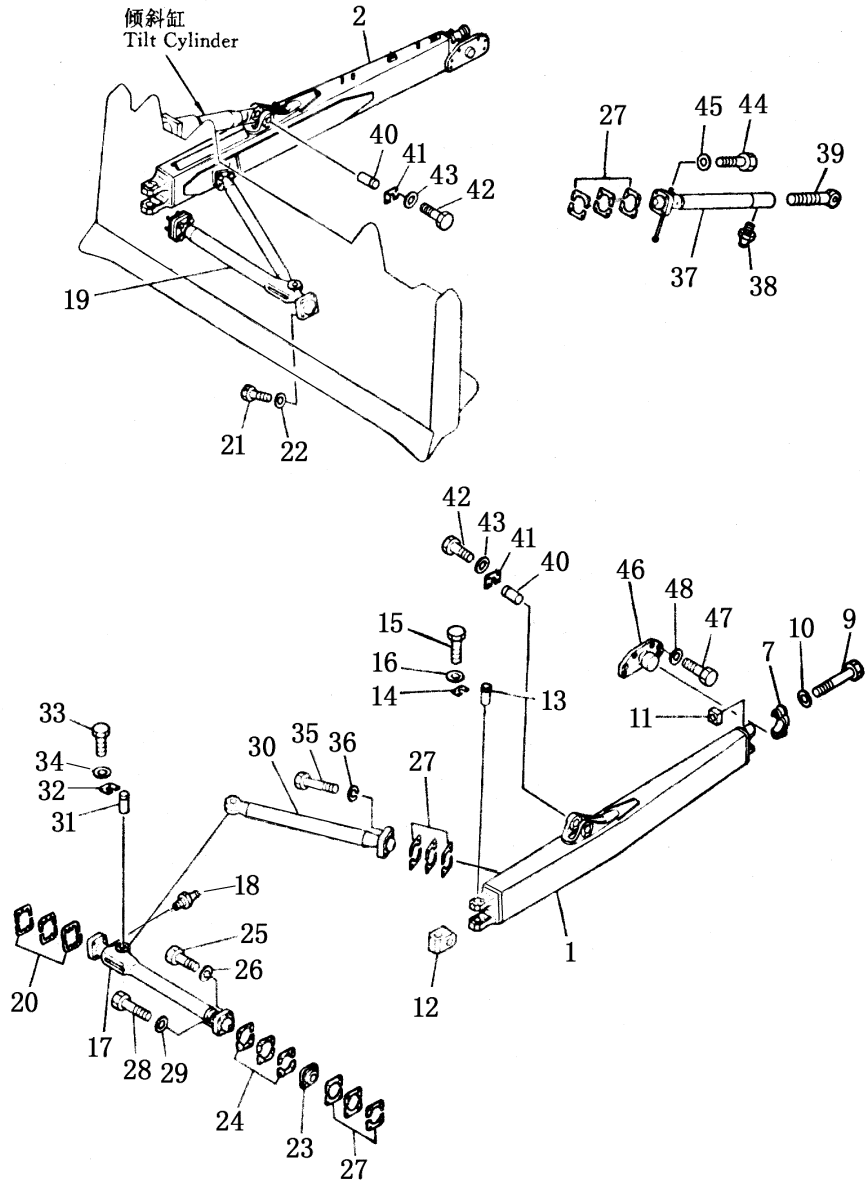

推 杆
STRAIGHT TILT FRAME

序号 Index No.	件 号 Part No.	名 称 Description	数 量 Q' ty
			SD22 SD22E SD22D
703-1	154-71-31151	左推杆 frame, l, h	1
2	154-71-31164	右推杆 frame, r, h	1
7	150-70-23244	螺盖 cap	2
9	154-71-31420	螺栓 bolt	4
10	01643-32780	加厚垫圈 washer	4
11	170-70-13141	螺帽 nut	4
12	154-71-22261	接头 joint	2
13	154-71-22470	销 pin	4
14	175-71-21330	锁垫 plate, lock	4
15	01010-51435	螺栓 bolt	16
16	01643-31445	加厚垫圈 washer	16
17	154-71-31191	左臂 arm, l, h	1
18	07020-00000	接头式压注油杯 fitting grease	1
19	154-71-31211	右臂 arm, r, h	1
20	175-71-31250	垫片 shim	8
	175-71-31260	垫片 shim	8
	175-71-31270	垫片 shim	4
21	01010-52490	螺栓 bolt	4
22	01643-32460	加厚垫圈 washer	4
23	154-71-31270	帽 cap	2
24	154-71-31310	垫片 shim	8
	154-71-31320	垫片 shim	8
	154-71-31330	垫片 shim	4
25	01010-51270	螺栓 bolt	4
26	01602-21236	弹簧垫圈 washer, spring	4
27	154-71-22390	垫片 shim	26
	154-71-22410	垫片 shim	26
	154-71-22420	垫片 shim	16
28	01011-52420	螺栓 bolt	8
29	01643-32460	垫圈 washer	8
30	154-71-31221	臂 arm	2
31	154-71-22480	销 pin	2
32	154-71-22490	锁垫 plate, lock	2
33	01010-51435	螺栓 bolt	8
34	01643-31445	垫圈 washer	8

推 杆
STRAIGHT TILT BLADE

序号 Index No.	件 号 Part No.	名 称 Description	数 量 Q' ty
			SD22 SD22E SD22D
703-35	01010-52490	螺栓 bolt	8
36	01643-32460	垫圈 washer	8
37	154-71-22371	支撑 brace	1
38	07020-00000	接头式压注油杯 fitting grease	1
39	154-71-21530	螺钉 screw	1
40	154-71-21290	销 pin	2
41	175-71-21330	锁垫 plate, lock	2
42	01010-51435	螺栓 bolt	8
43	01643-31445	垫圈 washer	8
44	01010-52490	螺栓 bolt	8
45	01643-32460	垫圈 washer	8
46	154-70-13214	耳轴 trunnion	2
47	01010-52250	螺栓 bolt	12
48	01643-32260	垫圈 washer	12

第 704 图 直 倾 铲 (SD22S 用)
 FIG. 704 STRAIGHT TILT BLADE (For SD22S)

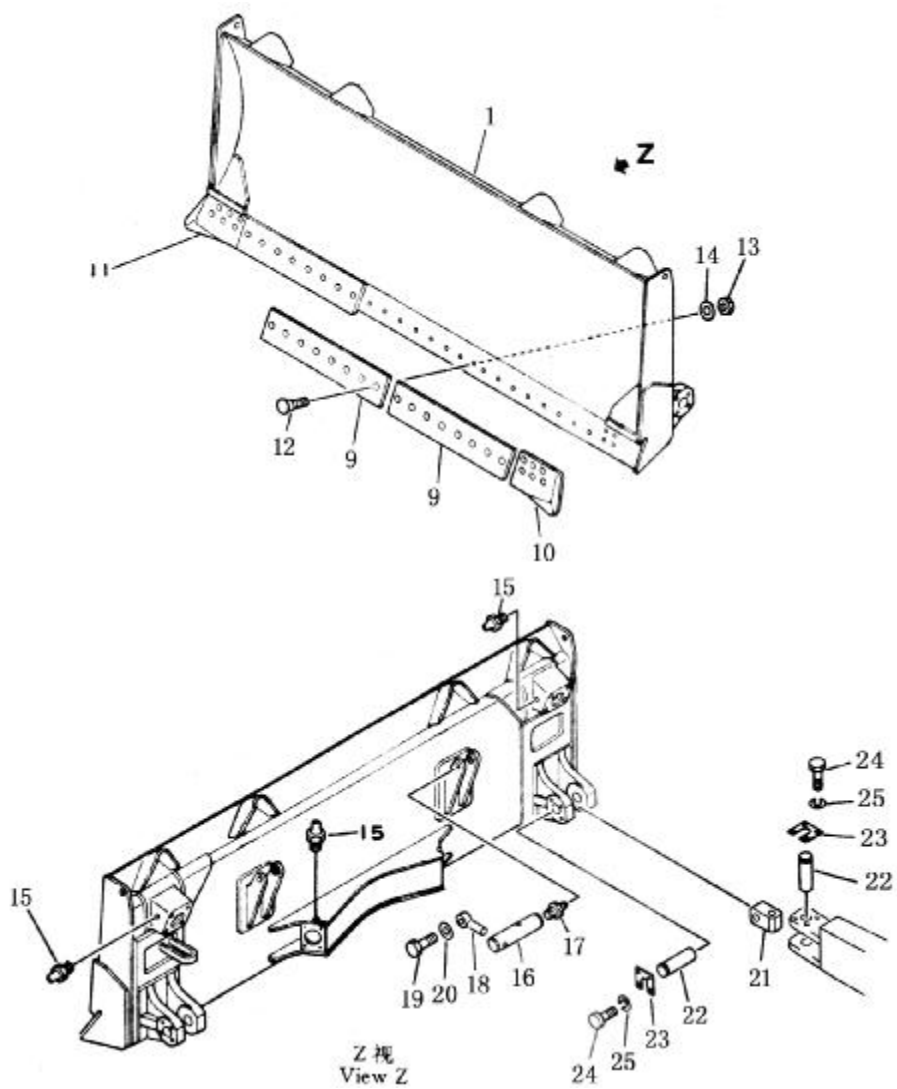

直 倾 铲(SD22S 用)
STRAIGHT TILT BLADE (For SD22S)

序号 Index No.	件 号 Part No.	名 称 Description	数量 Q'ty
			SD22S
704-1	TS220. 71. 3	刀头 blade	1
9	154-70-11314	切刃 edge, cutting	3
10	150-70-21356	左刀角 bil end, l	1
11	150-70-21346	右刀角 bil end, r	1
12	154-70-11143	螺栓 bolt	36
13	154-70-22270	螺帽 nut	36
14	01643-21845	加厚垫圈 washer	36
15	07020-00000	油杯 fitting, grease	2
16	154-70-22511	轴 shaft	2
17	07020-00000	油杯 fitting, grease	2
18	195-71-11520	销 pin	2
19	01010-51435	螺栓 bolt	2
20	01643-31445	加厚垫圈 washer	2
21	154-70-22261	接头 joint	2
22	154-70-22470	销 pin	4
23	175-71-21330	锁垫 plate, lock	4
24	01010-51435	螺栓 bolt	16
25	01643-31445	加厚垫圈 washer	16

第 705 图 推 杆 (SD22S 用)
FIG. 705 STRAIGHT AND TILT FRAME (For SD22S)

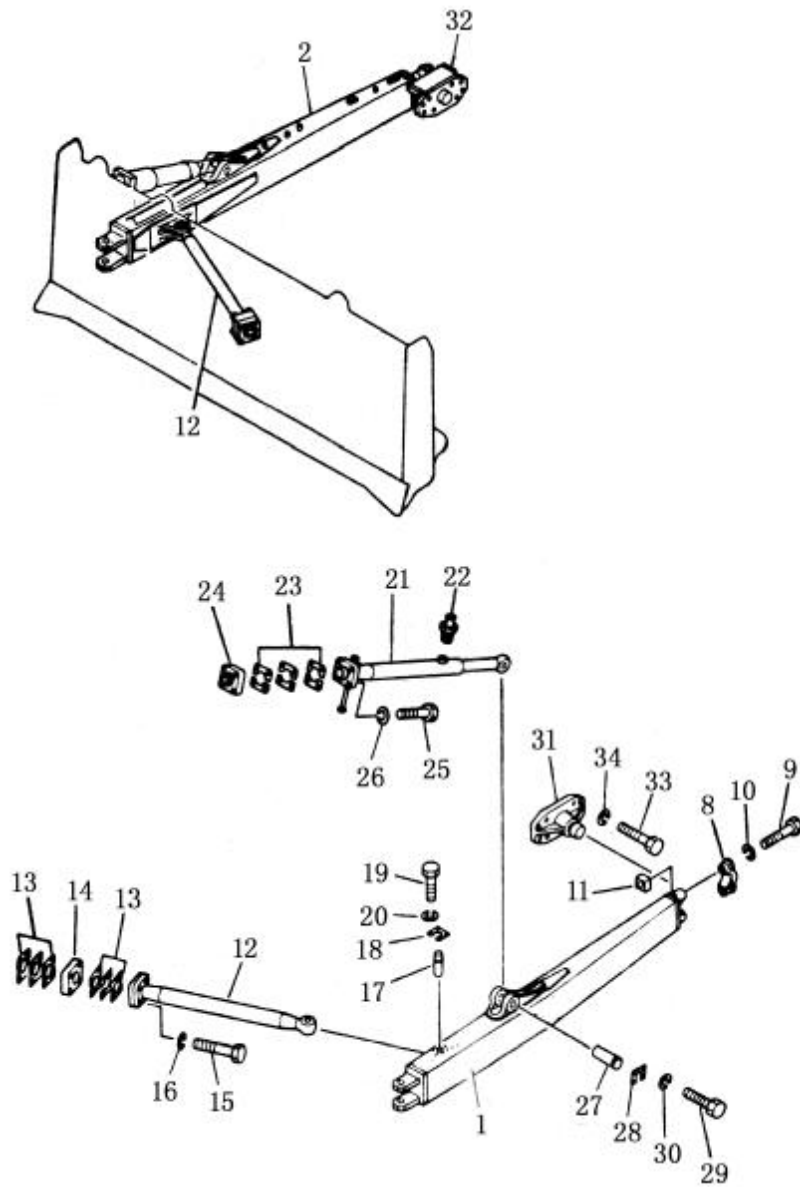

推 杆(SD22S 用)
STRAIGHT AND TILT FRAME (For SD22S)

序号 Index No.	件 号 Part No.	名 称 Description	数 量 Q' ty
			SD22S
705-1	TS220. 71. 2	左推杆 Frame. l	1
2	TS220. 71. 4	右推杆 Frame. r	1
8	150-70-23244	螺盖 Cap	2
9	154-71-31420	螺栓 bolt	4
10	01643-32780	加厚垫圈 washer	4
11	170-70-13141	螺帽 nut	4
12	154-71-31221	臂 arm	2
13	154-71-22390	垫片 shim	16
	154-71-22410	垫片 shim	32
	154-71-22420	垫片 shim	16
14	TS220. 71-2	压盖 Cap	2
15	01010-52490	螺栓 bolt	8
16	01643-32460	加厚垫圈 washer	8
17	154-71-22480	销 pin	2
18	154-71-22490	锁垫 plat, lock	2
19	01010-51435	螺栓 bolt	8
20	01643-31445	加厚垫圈 washer	8
21	154-71-22371	支撑 srm	1
22	07020-00000	油杯 fitting, grease	1
23	154-71-22390	垫片 shim	4
	154-71-22410	垫片 shim	8
	154-71-22420	垫片 shim	4
24	TS220. 71-1	压盖 Cap	2
25	01010-52420	螺栓 bolt	8
26	01643-32460	加厚垫圈 washer	8
27	154-71-21290	销 pin	2
28	125-71-21330	锁垫 plat, lock	2
29	01010-51435	螺栓 bolt	8
30	01643-31445	加厚垫圈 washer	8
31	TS220. 71. 1	耳轴 (左) trunnion, l	1
32	TS220. 71. 8	耳轴 (右) trunnion, r	1
33	01010-52250	螺栓 bolt	16
34	01643-32260	加厚垫圈 washer	16

第 706 图 松土器
 FIG. 706 RIPPER

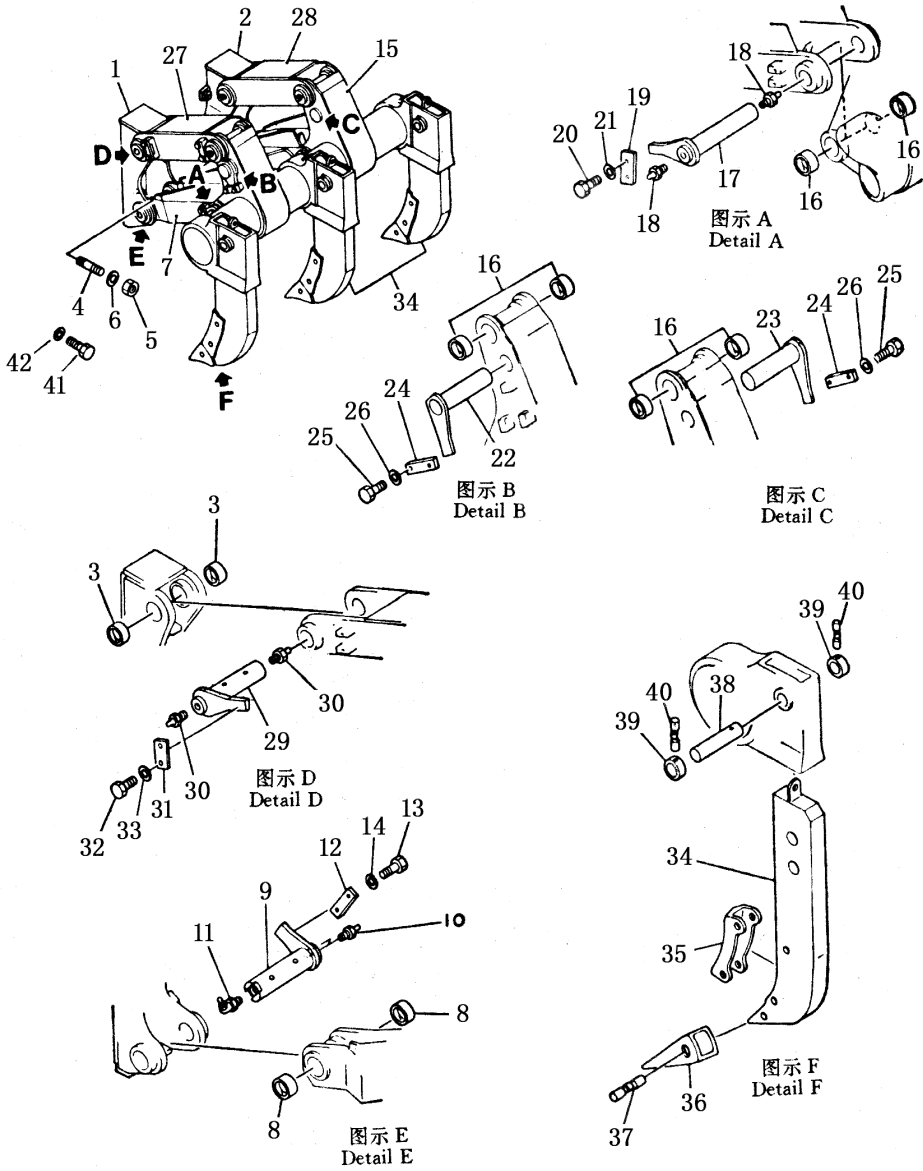

松土器
RIPPER

序号 Index No.	件号 Part No.	名称 Description	数量 Q' ty
706-1	154-78-14154	托架 (左) bracket, L. H.	1
2	154-78-14164	托架 (右) bracket, R. H.	1
3	154-78-14223	衬套 bushing	4
4	154-78-14281	双头螺栓 stud	4
5	01580-03326	螺母 nut	4
6	01643-33380	垫圈 washer	4
7	154-78-14126	连接架 link	1
8	154-78-14223	衬套 bushing	4
9	154-78-14173	销轴 pin	2
10	07020-00000	接头式压注油杯 fitting, grease	4
11	07020-00675	接头式压注油杯 fitting, grease	2
12	154-78-14290	板 plate	2
13	01010-51845	螺栓 bolt	4
14	01643-31845	垫圈 washer	4
15	154-78-14117	横梁 beam	1
16	154-78-14223	衬套 bushing	8
17	154-78-14191	销 pin	2
18	07020-00000	接头式压注油杯 fitting, grease	4
19	154-78-14290	板 plate	2
20	01010-51845	螺栓 bolt	4
21	01643-31845	垫圈 washer	4
22	154-78-14210	销 (左) pin, L. H.	1
23	154-78-14160	销 (右) pin, R. H.	1
24	154-78-14290	板 plate	2
25	01010-51845	螺栓 bolt	4
26	01643-31845	垫圈 washer	4
27	154-78-14133	连杆(左) link, L. H.	1
28	154-78-14143	连杆(右) link, R. H.	1

松土器
RIPPER

序号 Index No.	件 号 Part No.	名 称 Description	数量 Q' ty
706-29	154-78-14182	销轴 pin	4
30	07020-00000	接头式压注油杯 fitting, grease	8
31	154-78-14290	板 plate	4
32	01010-51845	螺栓 bolt	8
33	01643-31845	垫圈 washer	8
34	154-78-14349	松土支角 shank	3
35	154-78-31330	护板 protector	3
36	175-78-31230	齿尖 point	3
37	09244-02508	销套 pin	9
38	154-78-32430	销 pin	3
39	154-78-32440	套环 collar	6
40	09244-02489	销套 pin	6
41	01018-33390	螺栓 bolt	8
42	01643-33380	垫圈 washer	8

第 707 图 松土器管路
 FIG. 707 RIPPER PIPING

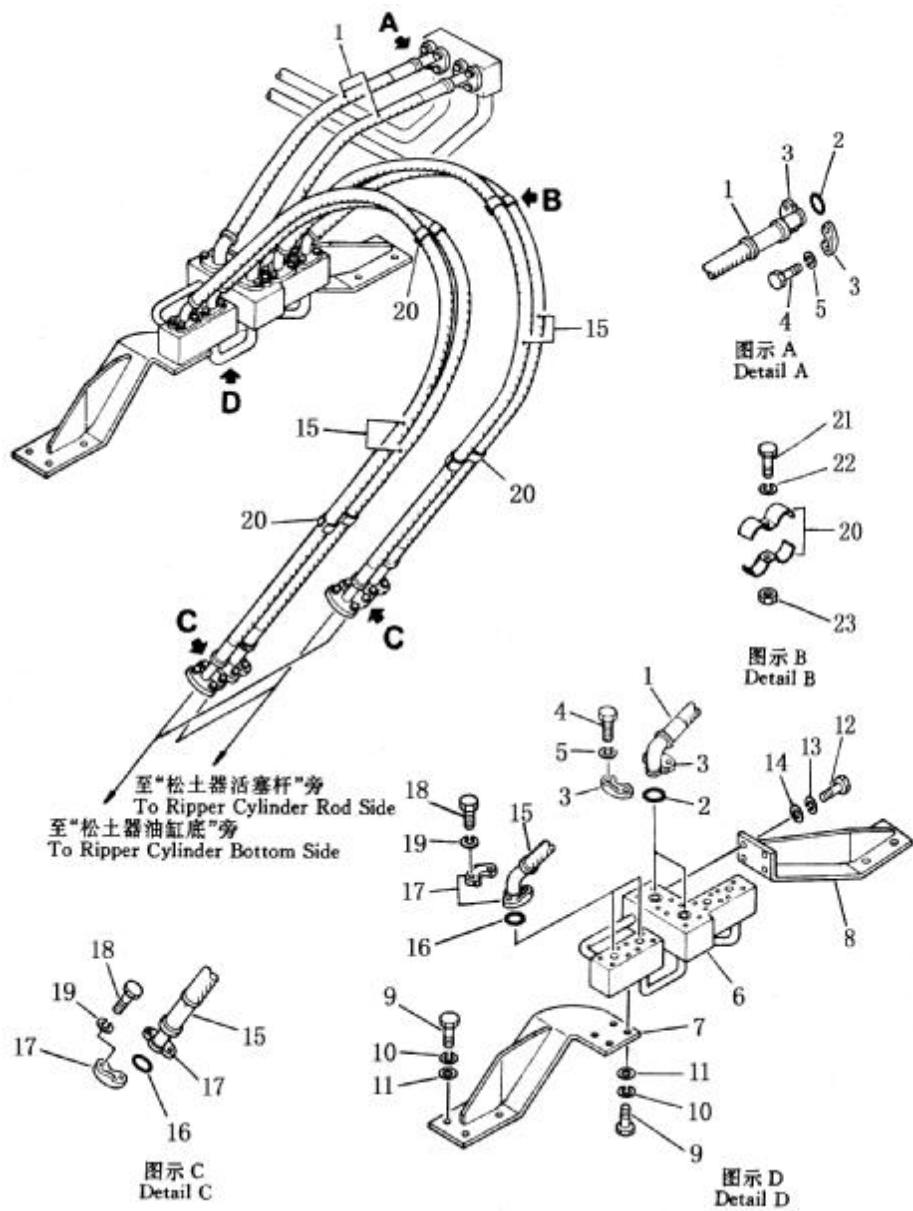

松土器管路
RIPPER PIPING

序号 Index No.	件 号 Part No.	名 称 Description	数量 Q' ty
707-1	07114-01006	软管 hose	2
2	07000-13032	O 型圈 o-ring	4
3	07371-31049	拼合凸缘 flange, split	8
4	07372-21030	螺栓 bolt	16
5	01602-21030	弹簧垫圈 washer, spring	16
6	154-78-32173	管 tube	1
7	154-78-32183	托架 (左) bracket, L. H.	1
8	154-78-32193	托架 (右) bracket, R. H.	1
9	01010-51030	螺栓 bolt	8
10	01602-21030	弹簧垫圈 washer, spring	8
11	01643-31032	垫圈 washer	8
12	01010-51030	螺栓 bolt	8
13	01602-21030	弹簧垫圈 washer, spring	8
14	01643-31032	垫圈 washer	8
15	07115-00616	软管 hose	4
16	07000-13025	O 型圈 o-ring	8
17	07371-30638	拼合凸缘 flange, split	16
18	01010-20830	螺栓 bolt	32
19	01602-20825	弹簧垫圈 washer, spring	32
20	150-78-18710	夹子 clamp	8
21	01010-51025	螺栓 bolt	4
22	01602-21030	弹簧垫圈 washer, spring	4
23	01580-11008	螺帽 nut	4

第 708 图 松土器油缸
 FIG. 708 RIPPER CYLINDER

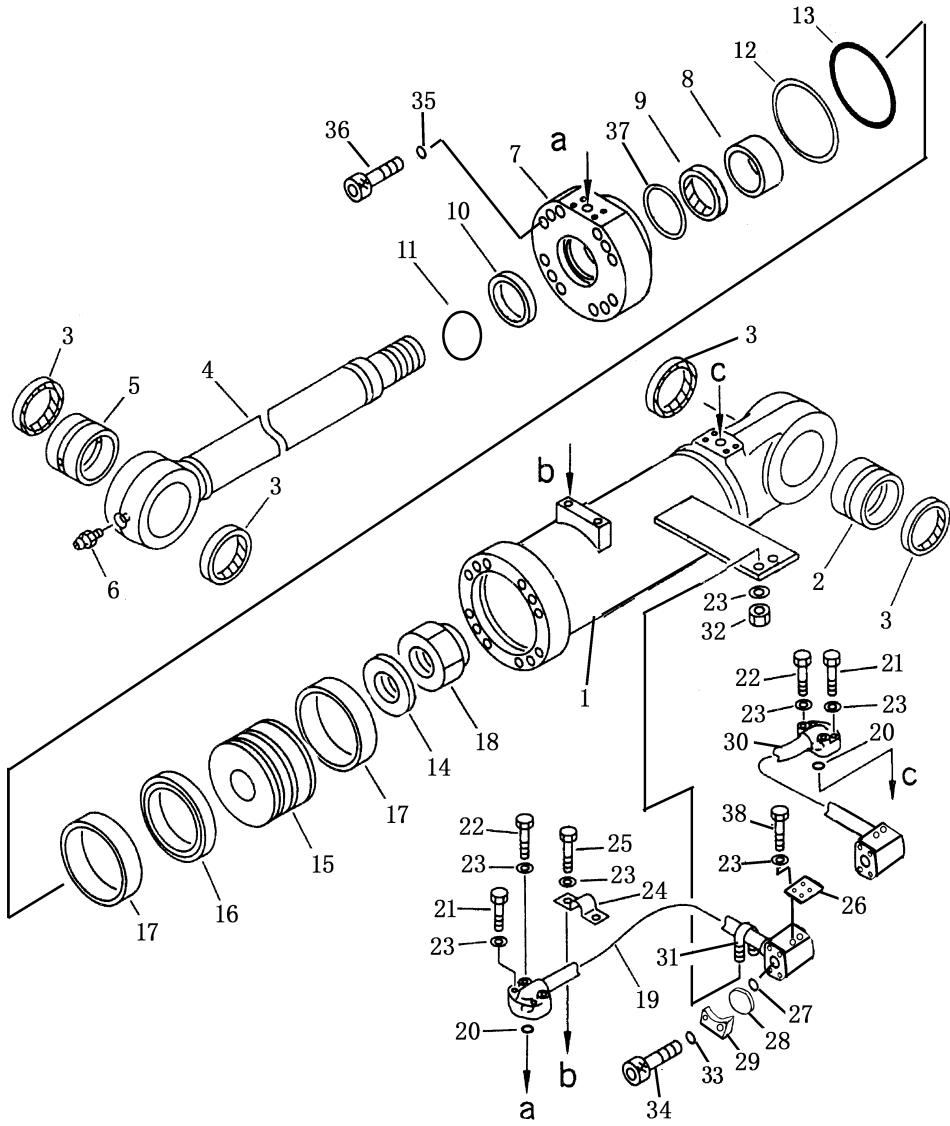

松土器油缸
RIPPER CYLINDER

序号 Index No.	图号 PART NO.	名称 DESCRIPTION	数量 Q'ty
708-1	23Y-64B-01100	缸体 body, cylinder	1
2	154-63-42320	衬套 bushing	1
3	07145-00075	防尘圈 seal, dust	4
4	23Y-64B-01200	活塞杆 rod, piston	1
5	154-63-42420	衬套 bushing	1
6	07020-01021	油杯 fitting, grease	1
7	23Y-64B-01003	缸头 head, cylinder	1
8	23Y-62B-01003	导向环 ring, guide	1
9	23Y-62B-01100	斯特封 seal	1
10	23Y-62B-01001	防尘圈 seal, dust	1
11	07000-12070	O形圈 O-ring	1
12	07146-02146	保护圈 ring, protect	1
13	07000-12145	O形圈 O-ring	1
14	144-63-42170	垫圈 washer	1
15	23Y-64B-01001	活塞 piston	1
16	23Y-64B-01300	格莱圈 ring	1
17	23Y-64B-01002	支承环 ring, support	2
18	144-63-42182	螺母 nut	1
19	154-63-42780	管(左) tube, L.H	1
	154-63-42880	管(右) tube, L.H	1
20	07000-13035	O形圈 O-ring	1
21	01010-51050	螺栓 bolt	4
22	01010-51055	螺栓 bolt	4
23	01643-31032	垫圈 washer	16
24	154-63-42870	夹块 block	1
25	01010-51040	螺栓 bolt	2
26	154-63-42770	板 plate	1
27	07000-13025	O形圈 O-ring	2
28	07378-10600	防尘盖 cover	2

松土器油缸
RIPPER CYLINDER

序号 Index No.	图 号 PART NO.	名 称 DESCRIPTION	数量 Q' ty
708-29	07371-30638	法兰 flange	4
30	154-63-42791	管(左) tube, L.H	1
	154-63-42891	管(右) tube, L.H	1
31	07283-23450	管夹 clip	1
32	01599-01011	螺母 nut	2
33	01643-30823	垫圈 washer	8
34	01010-50830	螺栓 bolt	8
35	01643-31645	垫圈 washer	12
36	01252-61680	螺钉 screw	12
37	23Y-62B-01002	KY 圈 KY-ring	1
38	01010-51025	螺栓 bolt	4

第 709 图 角 铲
FIG. 709 ANGLE BLADE

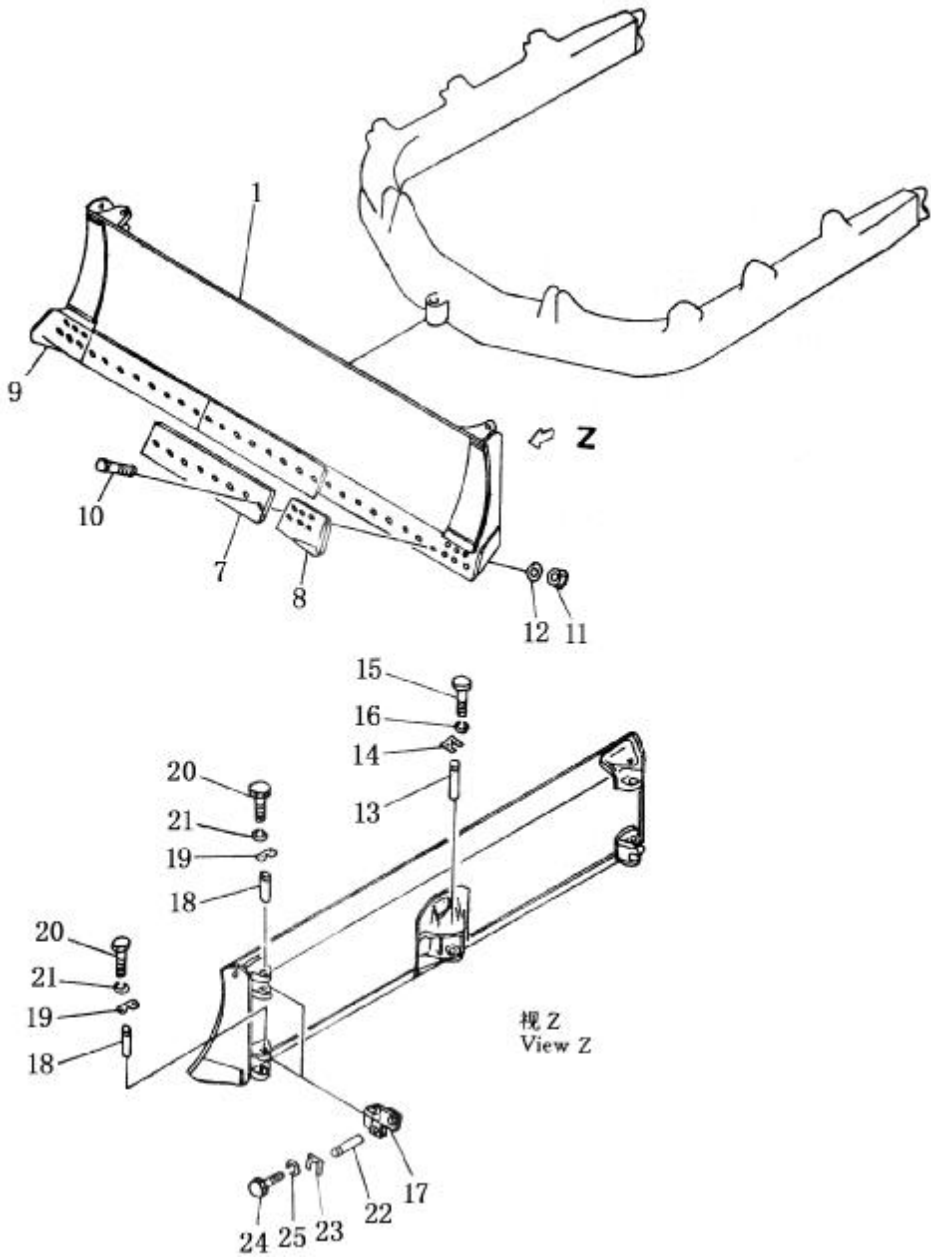

角 铲
ANGLE BLADE

序号 Index No.	件 号 Part No.	名 称 Description	数 量 Q' ty
			SD22 SD22E
709-1	154-70-11116	刀头 blade	1
7	154-70-11314	刀刃 edge, cutting	3
8	150-70-21356	左刀角 bit, end, L.	1
9	150-70-21346	右刀角 bit, end, R.	1
10	154-70-11143	螺栓 bolt	36
11	154-70-22270	螺帽 nut	36
12	01643-21845	垫圈 washer	36
13	150-70-23333	插销 pin	1
14	09257-06009	锁紧垫 shim, lock	1
15	01010-51435	螺栓 bolt	4
16	01643-31445	垫圈 washer	4
17	154-70-16280	连节 joint	4
18	154-70-16270	销 pin	4
19	154-70-16290	锁垫 plate, lock	4
20	01010-51435	螺栓 bolt	8
21	01643-31445	垫圈 washer	8
22	09255-01125	销 pin	4
23	09527-05009	锁紧垫 shim, lock	4
24	01010-51435	螺栓 bolt	16
25	01643-31445	垫圈 washer	16

第 710 图 弓形架
FIG. 710 U-FRAME

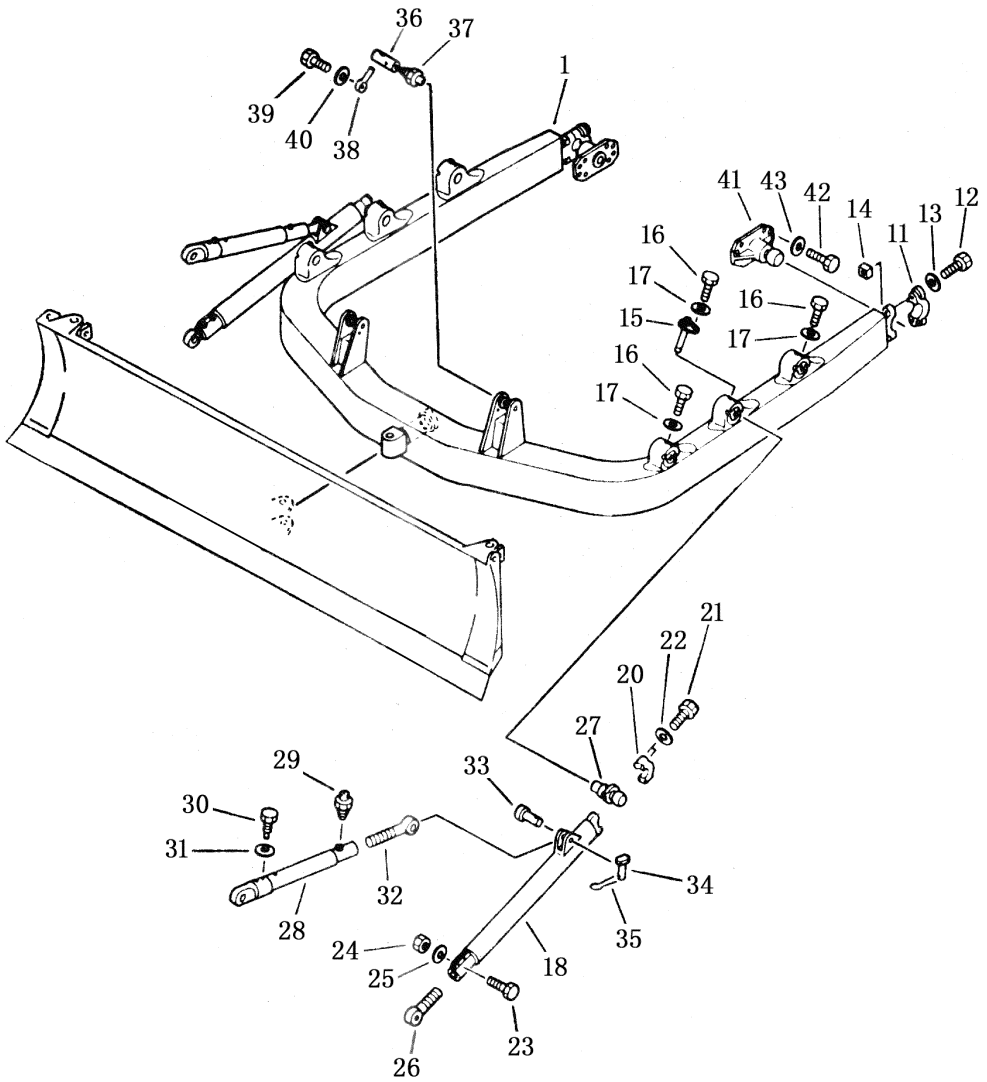

弓形架
U-FRAME

序号 Index No.	件号 Part No.	名称 Description		数量 Q' ty
				SD22 SD22E
710-1	154-70-31111	弓形架	U-frame	1
11	150-70-23244	螺盖	cap	2
12	154-71-31420	螺栓	bolt	4
13	01643-32780	垫圈	washer	4
14	170-70-13141	螺帽	nut	4
15	154-70-19181	插销	pin	2
16	01010-51420	螺栓	bolt	6
17	205-06-62270	垫圈	washer	6
18	154-70-12116	支撑	arm	2
20	175-70-12160	轴盖	cap	2
21	01010-52095	螺栓	bolt	8
22	01643-32060	垫圈	washer	8
23	01010-51880	螺栓	bolt	4
24	01580-11815	螺帽	nut	4
25	01643-31845	垫圈	washer	4
26	175-70-12130	螺杆	screw	2
27	154-70-12162	轴	shaft	2
28	154-70-17160	支撑	brace	2
29	07020-00000	油杯	fitting, grease	4
30	175-70-12221	螺栓	bolt	2
31	01643-31445	垫圈	washer	2
32	154-70-12251	丝杠	screw	2
33	150-70-13411	插销	pin	2
34	170-70-12240	插销	pin	2
35	04050-04025	开口销	pin, cotter	2
36	154-71-22511	销	pin	2
37	07020-00000	油杯	fitting, grease	2
38	195-71-11520	插销	pin	2
39	01010-51435	螺栓	bolt	2
40	01643-31445	垫圈	washer	2
41	154-70-13214	耳轴	trunnion	2
42	01010-52250	螺栓	bolt	12
43	01643-32260	垫圈	washer	12

第 711 图 U 形铲
FIG. 711 U-BLADE

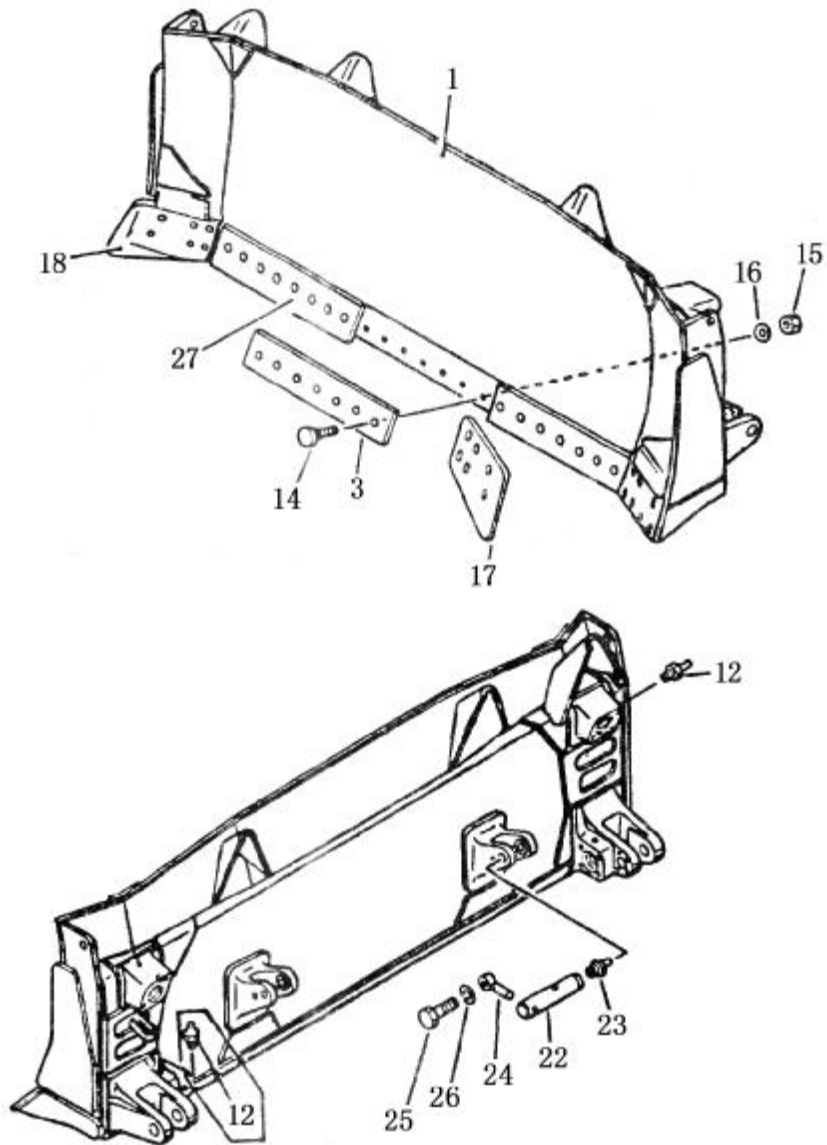

U 形 铲
U-BLADE

序 号 Index No.	件 号 Part No.	名 称 Description	数量 Q' ty
			SD22 SD22E
711-1	T220 • 72 • 1	U 形铲刀头 U-blade	1
12	07020-00000	油杯 fitting, grease	4
13	T220 • 72-1	刀刃(一) edge(1)	1
14	154-70-11143	螺栓 bolt	33
15	154-70-22270	螺帽 nut	33
16	01643-21845	加厚垫圈 washer	33
17	150-70-21356	左刀角 bit, end, L	1
18	150-70-21346	右刀角 bit, end, R	1
22	154-71-22511	轴 shaft	2
23	07020-00000	油杯 fitting, grease	2
24	195-71-11520	销 pin	2
25	01010-51435	螺栓 bolt	2
26	01643-31445	加厚垫圈 14 washer	2
27	T220 • 72-2	刀刃(二) edge(2)	2

电 气 系 统
ELECTRICAL SYSTEM

第 801 图 电气系统 (1/2)
 Fig. 801 ELECTRICAL SYSTEM

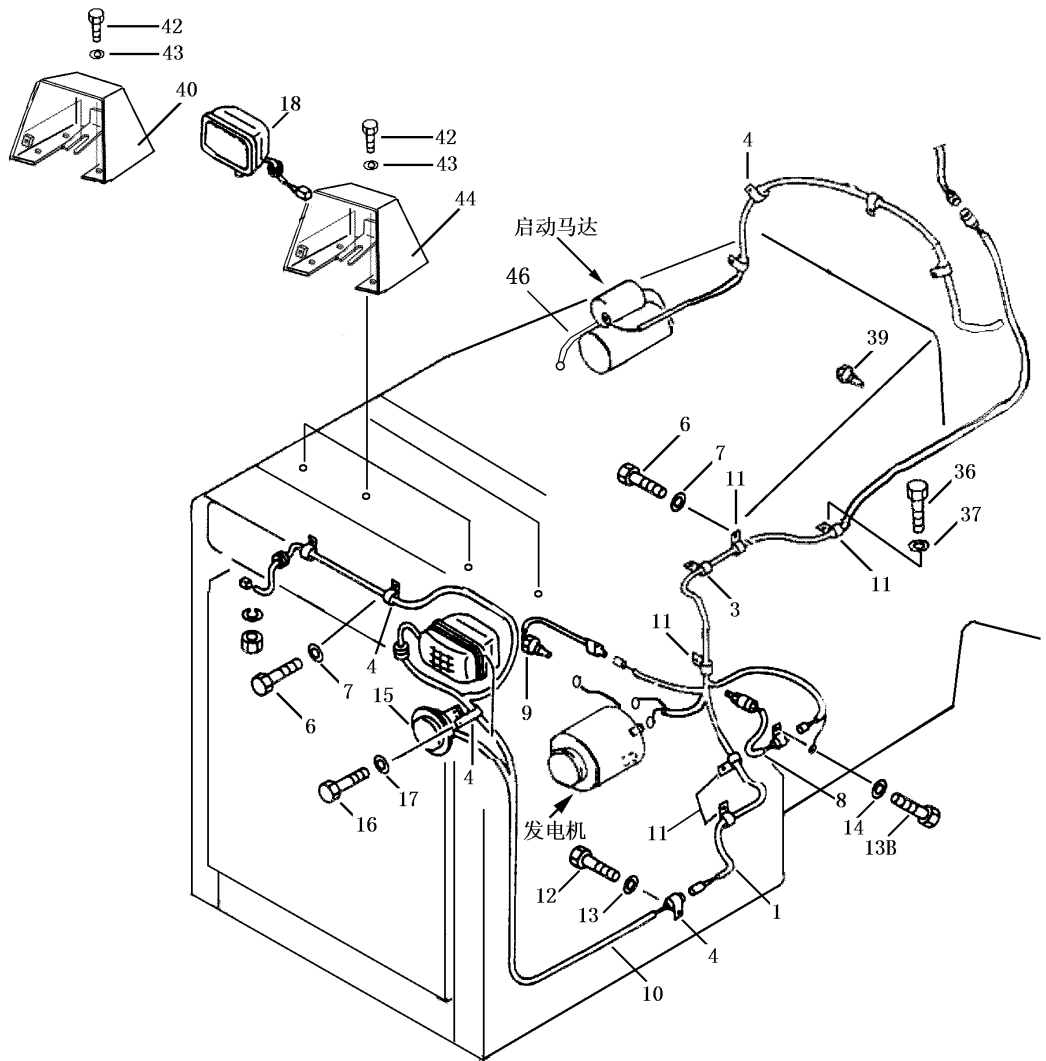

电气系统 (1/2)
ELECTRICAL SYSTEM

序号 Index No.	件号 Part No.	名称 Description	数量 Q'ty
1	17Y-07B-02000	线束 wiring harness	1
3	08035-02514	线夹 clip	1
4	08035-01512	线夹 clip	5
6	01010-51220	螺栓 bolt	4
7	01643-31232	垫圈 washer	4
8	D2300-00000	压力传感器 sensor, engine oil pressure	1
9	D2320-00000	温度传感器 sensor, water temperature	1
10	23Y-07B-07000	线束 wiring harness	1
11	08035-02510	线夹 clip	5
12	01010-51220	螺栓 bolt	1
13	01643-31232	垫圈 washer	1
14	01643-31032	垫圈 washer	1
15	D2711-10500	喇叭 horn	1
16	01010-50820	螺栓 bolt	2
17	01643-30823	垫圈 washer	2
18	D2401-07000	大灯 lamp ass'y	2
36	01010-51050	螺栓 bolt	1
37	01643-31032	垫圈 washer	1
39	D2160-00800	空滤指示器 air indicator	1
40	23Y-07B-13000	灯罩(右) cover R.H	1
42	01010-51220	螺栓 bolt	6
43	01643-31232	垫圈 washer	6
44	23Y-07B-12000	灯罩(左) cover L.H	1
45	16Y-07C-10000	护板 plate	2
46	23Y-07B-08000	接地线 wire, earth	1

第 802 图 电气系统 (2/2)
Fig.802 ELECTRICAL SYSTEM

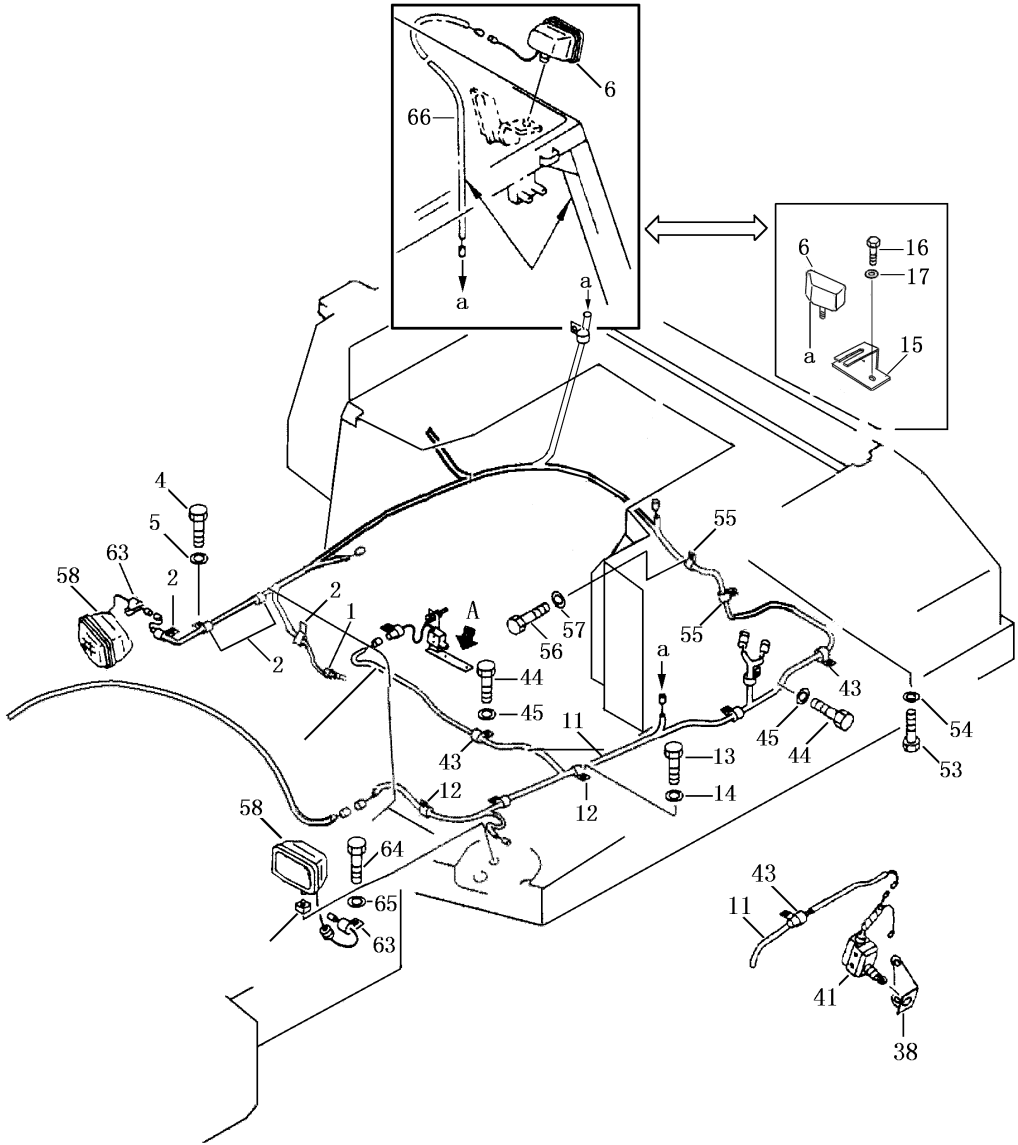

电气系统 (2/2)
ELECTRICAL SYSTEM

序号 Index No.	件号 Part No.	名称 Description	数量 Q'ty
1	D2320-00000	油温传感器 sensor, oil temperature	1
2	08036-11214	线夹 clip	4
4	01010-51220	螺栓 bolt	5
5	01643-31232	垫圈 washer	5
6	D2401-07000	大灯 lamp	1
12	08036-01814	线夹 clip	4
13	01010-51220	螺栓 bolt	3
14	01643-31232	垫圈 washer	3
15	16Y-07C-00008	支架 bracket	1
16	01010-51020	螺栓 bolt	4
17	01643-31032	垫圈 washer	4
38	154-06-36860	支架 bracket	1
41	D2590-00800	行程开关 switch, transmission	1
43	08036-11214	线夹 clip	7
44	01010-51220	螺栓 bolt	6
45	01643-31232	垫圈 washer	6
55	08036-11214	线夹 clip	2
56	01010-51220	螺栓 bolt	2
57	01643-31232	垫圈 washer	2
58	D2401-07000	大灯 lamp	2
63	08036-11214	线夹 clip	2
64	01010-51220	螺栓 bolt	2
65	01643-31232	垫圈 washer	2
66	23Y-07B-10000	线束 wire harness	1

第 803 图 仪 表 箱
Fig.803 INSTRUMENT BOX

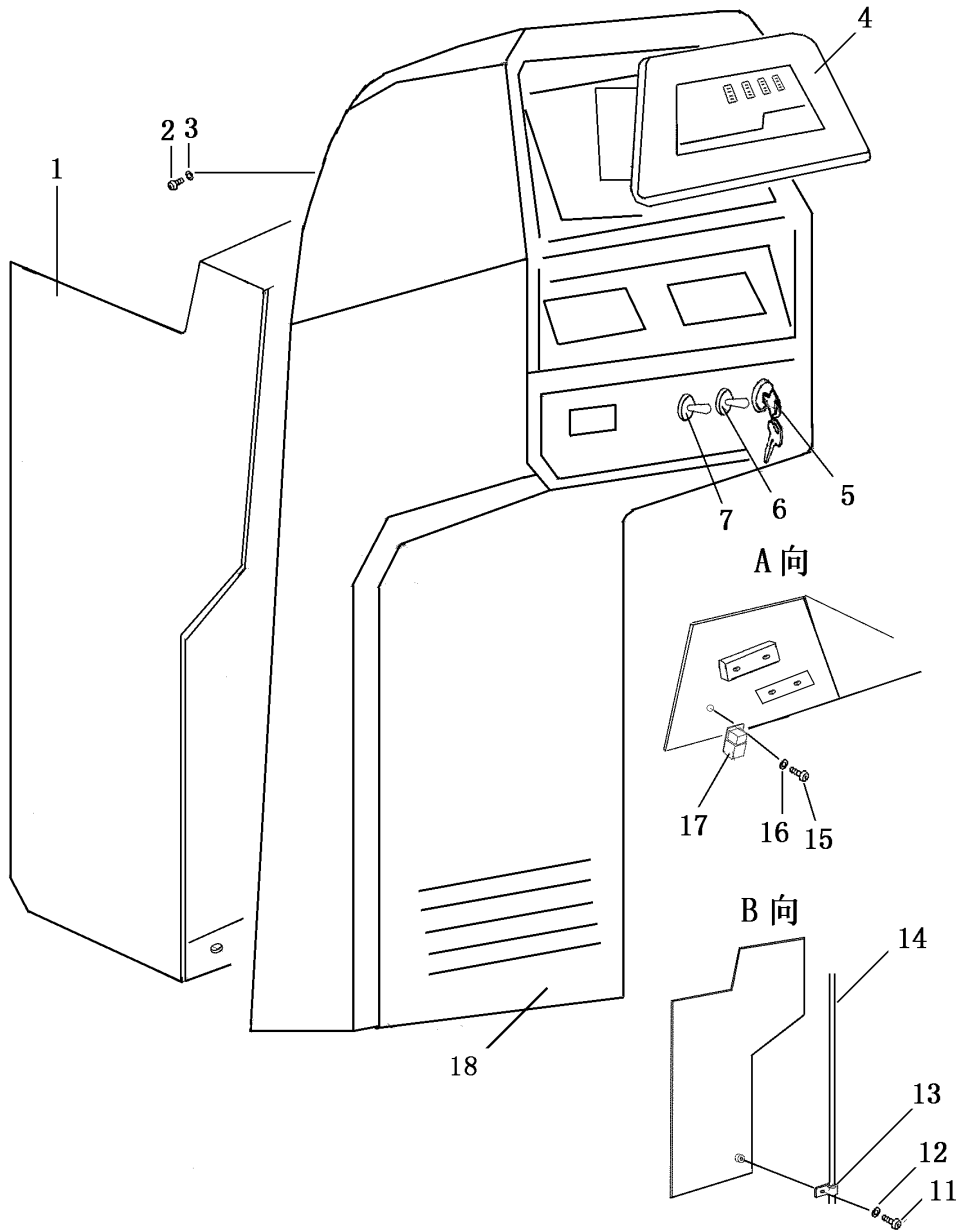

仪 表 箱
INSTRUMENT BOX

序号 No.	件 号 Part No.	名 称 Description	数量 Q'ty
1	23Y-07B-11000	箱 box	1
2	01220-30512	螺钉 screw	4
3	01641-20508	垫圈 washer	4
4	D2210-00000	组合仪表总成 combined instrument ass'y	1
4A	D2102-01000	机油压力表 oil pressure gauge	1
4B	D2112-12000	水温表 water temperature gauge	1
4C	D2122-15000	油温表 oil temperature gauge	1
4D	D2140-03200	电压表 voltage meter	1
4E	D2170-00000	计时表 time meter	1
4F	D2460-0000	报警单元 alarm unit	1
5	D2500-00000	启动开关 switch, starting	1
6	D2530-01500	前灯开关 switch, head lamp	1
7	D2530-01500	后灯开关 switch, rear lamp	1
11	01010—51016	螺栓 bolt	1
12	01643—31032	垫圈 washer	1
13	08035—02510	线夹 clip	1
14	17Y-07B-10000	线束 wire	1
15	01220-30412	螺钉 screw	1
16	01641-20405	垫圈 washer	1
17	D2660-02000	继电器 relay	1
18	17Y-91-01000	罩 cover	1

第 804 图 继电器和保险丝盒
Fig.804 RELAY AND FUSE BOX

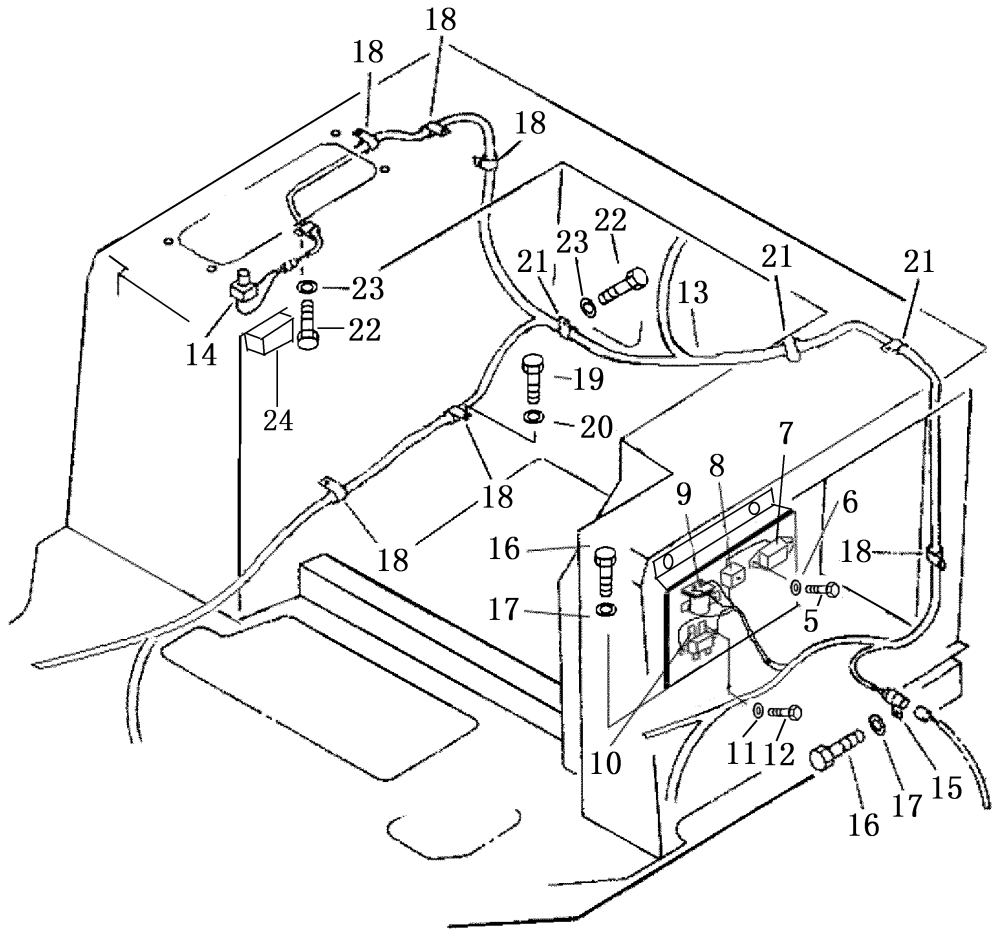

继电器和保险丝盒
RELAY AND FUSE BOX

序号 Index No.	件号 Part No.	名称 Description	数量 Q'ty
5	01220-30512	螺栓 bolt	2
6	01641-20508	垫片 washer	2
7	D2763-00900	保险丝盒 fuse box	1
8	D2762-00100	保险丝盒 fuse box	1
9	216537	启动继电器 starting relay	1
10	3006300	安全继电器 safety relay	1
11	01643-30623	垫片 shim	4
12	01220-30612	螺栓 bolt	4
13	23Y-07B-05000	线束 wire	1
14	D2510-06000	喇叭开关 switch, horn	1
15	08035-02512	线夹 clip	1
16	01010-51220	螺栓 bolt	1
17	01643-31232	垫片 shim	1
18	08035-02512	线夹 clip	6
19	01010-51220	螺栓 bolt	6
20	01643-31232	垫片 shim	6
21	08035-02512	线夹 clip	4
22	01010-51220	螺栓 bolt	4
23	01643-31232	垫片 shim	4
24	D2650-01100	喇叭继电器 relay horn	1

第 805 图 蓄电池和电池继电器
 Fig.805 BATTERY AND RELAY SWITCH

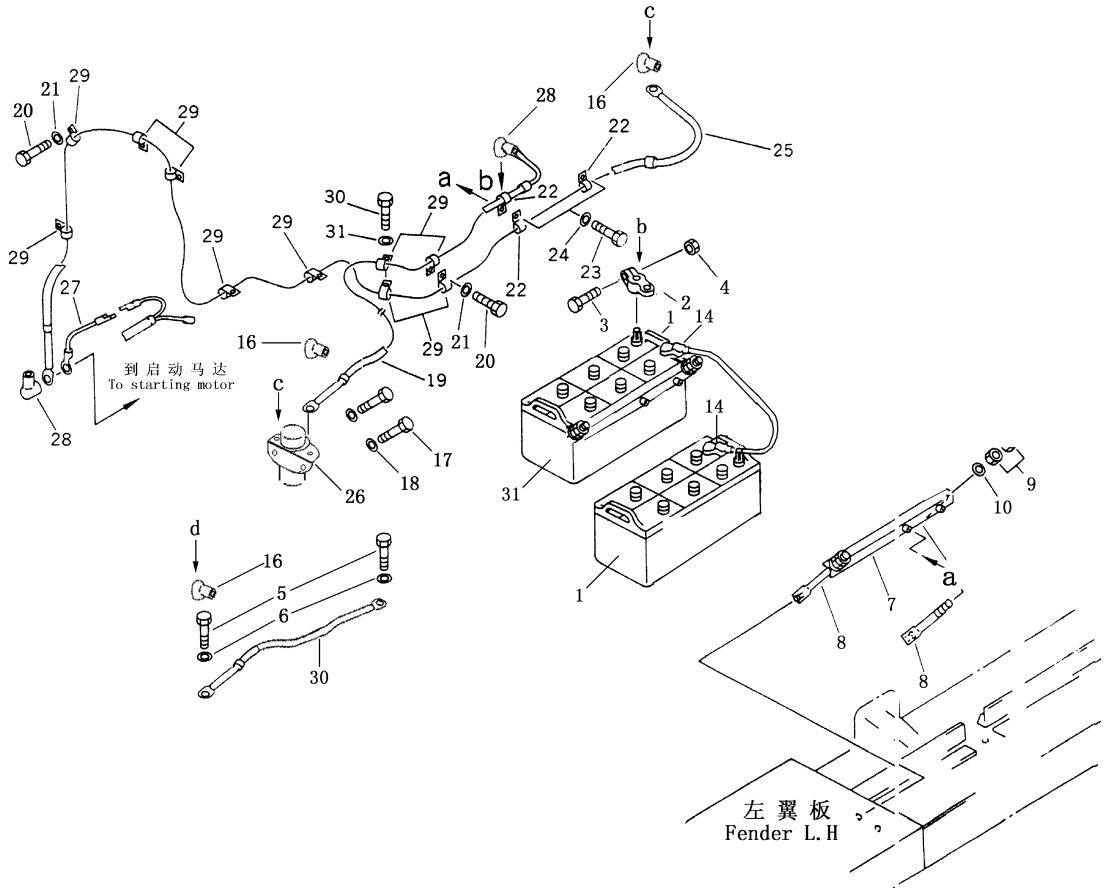

蓄电池与电池继电器

BATTERY AND RELAY SWITCH

序号 Index No.	件号 Part No.	名称 Description	数量 Q'ty
1	01010-20000	蓄电池 (200AH) battery	2
2	08000-00000	接线柱 “+” terminal “+”	2
	08000-00001	接线柱 “-” terminal “-”	2
3	01010-30830	螺栓 bolt	1
4	01580-00806	螺母 nut	1
5	01050-31018	螺栓 bolt	2
6	01640-01016	垫片 washer	2
7	195-06-19461	压板 holder	2
8	175-06-39621	拉杆 rod	4
9	01580-11008	螺母 nut	8
10	01643-31032	垫片 washer	4
14	08038-22511	罩 cap	2
15	195-06-18581	电缆 cable	1
16	08038-00518	罩 cap	3
17	01010-50820	螺栓 bolt	2
18	01643-30823	垫片 washer	2
19	23Y-07B-02000	电缆 cable	1
20	01010-51220	螺栓 bolt	8
21	01643-31232	垫片 washer	8
22	08035-03010	线夹 clip	3
25	23Y-07B-01000	电缆 cable	1
26	D2601-60000	电池继电器 relay	1
28	08038-00518	罩 cap	2
29	08035-03012	线夹 clip	10
30	23Y-07B-03000	电缆 cable	1
31	154-06-13263	橡胶垫 gasket, rubber	1

标牌布置图

MARKS AND PLATES

第 901 图 标牌布置图
 Fig. 901 MARKS AND PLATES

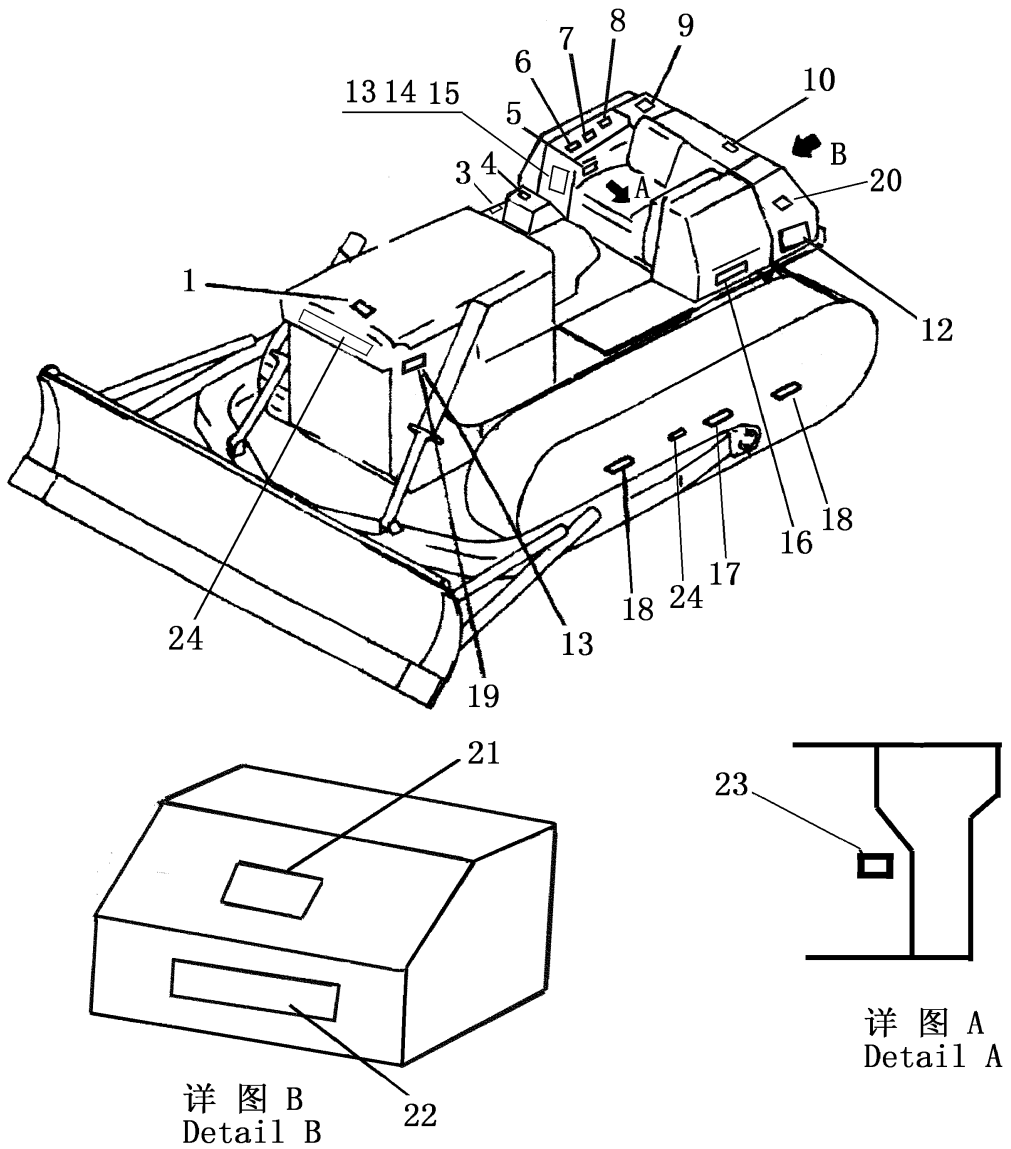

标牌布置图
MARKS AND PLATES

序号 Index No.	图号 PART NO.	名称 DESCRIPTION	数量 Q'ty	
			SD22	SD22S
1	09966-00100	散热器标牌 plate	1	1
3	17Y-74B-00004	集中测压标牌 plate	1	1
4	09967-00100	标牌 plate	1	1
5	09685-00004	转向制动锁定标牌 plate	1	1
6	09670-00001	铲刀操纵标牌 plate	1	1
7	09685-00002	操纵杆锁定标牌 plate	4	4
8	09671-31683	松土器操纵标牌 plate	1	1
9	09965-00100	工作油箱使用说明标牌 plate	1	1
10	09656-90080	燃油箱使用说明标牌 plate	1	1
12	09964-13000	山推厂徽 (S30) logo, SHANTUI	3	3
13	04418-00306	铆钉 rivet	8	8
14	D85-18-01	润滑图表 lubricating table	1	1
15	23Y-90-00005	润滑图表 (英) lubricating table	1	1
16	23Y-90B-00001	标牌 plate	2	
	158-90-00001	标牌 plate		2
17	09960-01012	重心标牌 plate	1	1
18	09963-00100	起吊标牌 plate	2	2
19	09962-00100	铭牌 plate	1	1
20	09961-00100	服务标牌 plate	1	1
21	17Y-90B-00006	标牌 plate	1	1
22	09685-00002	变速杆锁定标牌 plate	1	1
23	09657-00100	履带调整安全牌 plate	2	2
24	23Y-90B-00002	标牌 plate	1	1

山 推 股 份
SHANTUI

地址：中国山东济宁市吴泰闸路71号

邮编：272023

网址：www.shantui.com

2004 年版